



POLBAN

PETA PROSES BISNIS (PPB)
POLITEKNIK NEGERI BANDUNG

EDISI I, TAHUN 2018

Bizagi Modeler

KATA PENGANTAR

Penyusunan Peta Proses Bisnis dimaksudkan sebagai acuan bagi setiap instansi pemerintah untuk melakukan penataan ketatalaksanaan di lingkungan instansi pemerintah khususnya di Politeknik Negeri Bandung guna melaksanakan visi, misi, tujuan, dan strategi organisasi, sebagaimana yang tertuang dalam Peraturan Menteri Pendayagunaan Aparatur Negara dan Reformasi Birokrasi Republik Indonesia Nomor 19 Tahun 2018 tentang Penyusunan Peta Proses Bisnis Instansi Pemerintah.

Penataan ketatalaksanaan merupakan salah satu area perubahan dalam reformasi birokrasi Politeknik Negeri Bandung untuk mewujudkan organisasi instansi pemerintah yang tepat fungsi, tepat ukuran, dan tepat proses.

Selain itu Peta Proses Bisnis POLBAN bertujuan agar Politeknik Negeri Bandung mampu melaksanakan tugas dan fungsi secara efektif dan efisien sebagai institusi pendidikan bidang vokasi, serta dapat dengan mudah mengomunikasikan baik kepada pihak internal (mahasiswa, tenaga pendidik dan tenaga kependidikan) maupun pihak eksternal (orang tua mahasiswa, pengguna lulusan, dan mitra kerja lainnya) mengenai proses bisnis yang dilakukan untuk mencapai visi, misi, dan tujuan.

Bandung, 29 Oktober 2018,

Tim Penyusun Peta Proses Bisnis

Politeknik Negeri Bandung

DAFTAR ISI

KATA PENGANTAR	i
DAFTAR ISI	ii
1. PETA PROSES BISNIS POLBAN	1
2. PENGEMBANGAN PENDIDIKAN	2
3. PROSES BELAJAR MENGAJAR.....	3
4. SELEKSI MAHASISWA BARU.....	4
5. PENETAPAN KETENTUAN PENDAFTARAN DAN SELEKSI.....	5
6. PEMBOBOTAN DAN SELEKSI	6
7. PENDAFTARAN PMDK.....	7
8. SELEKSI BERKAS PENDAFTARAN DAN PENETAPAN CAMABA JALUR PMDK	8
9. PENDAFTARAN SMB TULIS.....	9
10. SELEKSI UJIAN TULIS	10
11. P2AI (AKTIVITAS INSTRUKSIONAL)	11
12. KURIKULUM	12
13. RENCANA PEMBELAJARAN SEMESTER.....	13
14. E-LEARNING.....	14
15. METODOLOGI PEMBELAJARAN.....	15
16. METODOLOGI PENGAJARAN	16
17. UP. MKU	17
18. BIMBINGAN BELAJAR (BIMBEL)	18
19. PENERBITAN JURNAL SIGMAMU	19
20. KULIAH DOSEN TAMU.....	20
21. AKREDITASI PROGRAM STUDI	21
22. PENELITIAN PENDIDIKAN	22
23. PENELITIAN BERBASIS RISET	23
24. PENGABDIAN KEPADA MASYARAKAT.....	24
25. PKM KERJASAMA.....	25
26. PEMBINAAN SIVITAS AKADEMIKA	26
27. PEMBINAAN TENAGA KEPENDIDIKAN	27
28. PEMBINAAN TENAGA PENDIDIK/DOSEN	28
29. SATUAN PENJAMINAN MUTU	29
30. AUDIT MUTU INTERNAL	30
31. PELAKSANAAN AMI POLBAN	31
32. SOSIALISASI HASIL PELAKSANAAN AMI POLBAN	32
33. VISITASI AMI.....	33

34.	LAPORAN KEGIATAN AMI & RTM	34
35.	SATUAN PENGAWASAN INTERNAL.....	35
36.	RENCANA KERJA SPI	36
37.	AUDIT MANDATORY	37
38.	AUDIT INSIDENTAL.....	38
39.	LAPORAN REVIU - TUGAS BIDANG SPI	39
40.	PELAPORAN AUDIT SPI.....	40
41.	PELAYANAN ADMINISTRASI.....	41
42.	LAYANAN ADM AKADEMIK	42
43.	KALENDER AKADEMIK.....	43
44.	MENYIAPKAN KARTU RENCANA STUDI (KRS).....	44
45.	PELANTIKAN MAHASISWA BARU	45
46.	REGISTRASI MAHASISWA BARU	46
47.	REGISTRASI MAHASISWA LAMA.....	47
48.	IDENTIFIKASI DAN JADWAL KULIAH	48
49.	PENERBITAN DOKUMEN AKADEMIK.....	49
50.	PENERBITAN SKPI.....	50
51.	REKOMENDASI CA	51
52.	PENERBITAN SK CA.....	52
53.	CUTI AKADEMIK	53
54.	AKTIF KEMBALI DARI CUTI AKADEMIK	54
55.	PELAKSANAAN UJIAN	55
56.	PEMBERHENTIAN MAHASISWA	56
57.	PELAPORAN PDPT POLBAN	57
58.	ENTRY NILAI BBPM (MANUAL)	58
59.	ENTRY NILAI BBPM (ON LINE).....	59
60.	KETIDAKHADIRAN MAHASISWA.....	60
61.	PENERBITAN SURAT PERINGATAN	61
62.	PENERBITAN SP 1	62
63.	PENERBITAN SP 2	63
64.	PENERBITAN SP 3	64
65.	KUNJUNGAN INDUSTRI.....	65
66.	PENGEOLAAN KEGIATAN KULIAH DOSEN TAMU.....	66
67.	LEGALISASI DOKUMEN AKADEMIK.....	67
68.	TRANSLATE DOKUMEN AKADEMIK.....	68
69.	MENCETAK DAFTAR NILAI/TRANSKRIP.....	69

70.	MENYUSUN CP SESUAI KKNi.....	70
71.	MENYIAPKAN DOKUMEN SKPI.....	71
72.	PEMBUATAN JADWAL UJIAN	72
73.	LAYANAN TUGAS AKHIR.....	73
74.	CETAK ABSENSI MAHASISWA	74
75.	PENERBITAN SURAT KETERANGAN	75
76.	PENERBITAN SURAT KETERANGAN PENGGANTI IJAZAH	76
77.	MENGUMPULKAN DATA AKADEMIK	77
78.	PENGELOLAAN PDDIKTI	78
79.	PERSIAPAN UJIAN	79
80.	REKAP KEHADIRAN DOSEN	80
81.	REKAP MENGAJAR DOSEN PARTIMER	81
82.	PRAKTIKUM DI LABORATORIUM	82
83.	PEMINJAMAN ALAT DI LABORATORIUM	83
84.	PEMINJAMAN BAHAN DI LABORATORIUM	84
85.	PENILAIAN KARYA ILMIAH DOSEN	85
86.	REKAPITULASI & OLAH DATA	86
87.	SERTIFIKASI DOSEN	87
88.	EVALUASI KELULUSAN/YUDISIUM	88
89.	CAPAIAN HASIL BELAJAR MAHASISWA.....	89
90.	ADMINISTRASI WISUDA	90
91.	LAYANAN ADMINISTRASI PERENCANAAN DAN SISTEM INFORMASI.....	91
92.	PENGELOLAAN SARANA TEKNOLOGI INFORMASI DAN KOMUNIKASI	92
93.	PERBAIKAN SARANA TIK	93
94.	INSTALASI SARANA TIK	94
95.	PENGEMBANGAN SISTEM INFORMASI.....	95
96.	PENGELOLAAN JARINGAN	96
97.	PASANG BARU JARINGAN.....	97
98.	PERBAIKAN JARINGAN.....	98
99.	PENGELOLAAN WEB.....	99
100.	LAYANAN EMAIL.....	100
101.	LAYANAN HOSTING	101
102.	PERENCANAAN ANGGARAN.....	102
103.	PEMBAGIAN PAGU JURUSANUNIT	103
104.	USULAN PENGADAAN BARANG/ALAT LAB DARI PRODI/SUB UNIT.....	104
105.	PENYUSUNAN RAB KEGIATAN	105

106.	MONITORING & REVISI ANGGARAN	106
107.	LAYANAN ADM KEMAHASISWAAN	107
108.	KELEMBAGAAN DAN PEMBINAAN	108
109.	KOMISI DISIPLIN MAHASISWA	109
110.	BELA NEGARA	110
111.	KEGIATAN ORMAWA	111
112.	KEWIRUSAHAAN	112
113.	KOMPETISI	113
114.	KOMPETISI BELMAWA	114
115.	KOMPETISI NON BELMAWA DAN UNDANGAN FESTIVAL	115
116.	LAYANAN ALUMNI	116
117.	JOB PLACEMENT AND ASSESSMENT CENTRAL	117
118.	COLLECTING DATABASE PELAMAR	118
119.	RECRUITMENT ON CAMPUS	119
120.	TRACER STUDY	120
121.	LAYANAN KESEJAHTERAAN MAHASISWA	121
122.	LAYANAN BEASISWA	122
123.	LAYANAN ASURANSI	123
124.	BANTUAN IOM UNTUK SPP DAN TUGAS AKHIR	124
125.	BANTUAN IOM UNTUK PENGEMBANGAN MINAT DAN BAKAT	125
126.	BANTUAN PROGRAM BIDIK MISI	126
127.	INKUBATOR BISNIS POLBAN	127
128.	PENGHARGAAN KEGIATAN KOMPETISI	128
129.	PROGRAM PENGENALAN KAMPUS	129
130.	PENINGKATAN KARAKTER DAN SOFT SKILL	130
131.	PPKK	131
132.	METAGAMA	132
133.	STUDIUM GENERAL	133
134.	LEADERSHIP	134
135.	PMW	135
136.	BIMBINGAN, KOSELING DAN PENDAMPINGAN	136
137.	PEMBINAAN MINAT & BAKAT	137
138.	PKM KERJASAMA	138
139.	PILMAPRES	139
140.	KERJASAMA INTERNASIONAL MELALUI MOU	140
141.	PUBLIKASI INFORMASI KEMAHASISWAAN	141

142.	PUBLIKASI INFO LOKER.....	142
143.	LAYANAN ADM UMUM & KEUANGAN.....	143
144.	LAYANAN TATA USAHA	144
145.	KESEKRETARIATAN	145
146.	PENERBITAN NASKAH DINAS DIREKTUR	146
147.	PENDISTRIBUSIAN NASKAH DINAS.....	147
148.	PENGAJUAN KEBUTUHAN BARANG DAN JASA	148
149.	PENERBITAN SK KEGIATAN, KEPANITIAAN, DAN LAINNYA	149
150.	PENGELOLAAN SURAT MASUK (UNIT KERJA LAIN)	150
151.	SURAT MASUK UNIT UPT PP	151
152.	SURAT MASUK UNIT KEPEGAWAIAN.....	152
153.	PENGELOLAAN SURAT JURUSAN/PRODI/UP.MKU	153
154.	PENGELOLAAN SURAT KELUAR (UNIT KERJA LAIN)	154
155.	SURAT KELUAR UPT PP	155
156.	SURAT KELUAR UNIT SUBAGIAN KEPEGAWAIAN.....	156
157.	SURAT KELUAR UNIT UPT KOMPUTER	157
158.	SURAT KELUAR UNIT UPT STUDIO GAMBAR.....	158
159.	KERUMAHTANGGAAN	159
160.	KEBERSIHAN KAMPUS.....	160
161.	KEBERSIHAN DALAM GEDUNG	161
162.	KEBERSIHAN LINGKUNGAN KAMPUS.....	162
163.	PENGELOLAAN SAPRA	163
164.	PENGELOLAAN GUDANG PERSEDIAAN PUSAT	164
165.	PELAYANAN TRANSAKSI PERSEDIAAN	165
166.	PELAKSANAAN STOCK OPNAME.....	166
167.	PELAPORAN PERSEDIAAN PUSAT	167
168.	PENGELOLAAN BARANG MILIK NEGARA	168
169.	PENGELOLAAN DATA ASET LANCAR	169
170.	PENGELOLAAN DATA ASET TETAP.....	170
171.	PELAPORAN BMN	171
172.	KEARSIPAN.....	172
173.	PENCATATAN ARSIP.....	173
174.	PENATAAN ARSIP	174
175.	PENGLASIFIKASIAN ARSIP.....	175
176.	PEMELIHARAAN ARSIP.....	176
177.	PEMINJAMAN ARSIP.....	177

178.	PENYIMPANAN ARSIP	178
179.	PENGALIHMEDIAAN ARSIP	179
180.	PENCIPTAAN ARSIP	180
181.	PEMUSNAHAN ARSIP	181
182.	KEPEGAWAIAN	182
183.	PENERIMAAN FORMASI CPNS.....	183
184.	PENERIMAAN CPNS	184
185.	PENERIMAAN PEGAWAI KONTRAK	185
186.	PELAKSANAAN DIKLAT PRAJABATAN CPNS.....	186
187.	PELAKSANAAN PENDIDIKAN DAN PELATIHAN PEGAWAI	187
188.	PELAKSANAAN DIKLAT	188
189.	PEMBERIAN IZIN BELAJAR	189
190.	PEMBUATAN PERJANJIAN KERJA WAKTU TERTENTU	190
191.	PEMBUATAN SURAT KETERANGAN KERJA	191
192.	PEMBUATAN KARPEG.....	192
193.	PEMBUATAN KARSU/KARIS	193
194.	PEMBUATAN KARTU INDONESIA SEHAT (KIS).....	194
195.	PEMBUATAN KARTU PESERTA TASPEN.....	195
196.	PENERBITAN FORMULIR PENILAIAN PRESTASI KERJA CPNSPNS.....	196
197.	PENERBITAN SK KGB.....	197
198.	PENERBITAN SK KEGIATAN	198
199.	PENERBITAN SK PEJABAT STRUKTURAL JURUSAN	199
200.	PENERBITAN SURAT TUGAS BELAJAR.....	200
201.	CUTI BERSALIN	201
202.	CUTI BESAR	202
203.	CUTI DI LUAR TANGGUNGAN NEGARA.....	203
204.	CUTI SAKIT.....	204
205.	CUTI TAHUNAN.....	205
206.	PENGAJUAN TUNJANGAN KELUARGA (KP-4)	206
207.	PENGANGKATAN CPNS MENJADI PNS.....	207
208.	PENSIUN PNS KARENA MENCAPI BUP (NORMAL).....	208
209.	PENSIUN DINI PNS	209
210.	PENSIUN PNS KARENA MENINGGAL DUNIA.....	210
211.	PENSIUN PNS KARENA SAKIT (KEUZURAN)	211
212.	PENYUSUNAN FORMASI CPNS	212
213.	ROTASI TENAGA KEPENDIDIKAN.....	213

214.	USUL ALIH STATUS MENJADI DOSEN.....	214
215.	USUL PEMBERHENTIAN DENGAN HORMAT.....	215
216.	USUL STATUS MENJADI DOSEN.....	216
217.	USULAN SURAT TUGAS BELAJAR.....	217
218.	PENGUSULAN PENGHARGAAN SATYALANCANA KARYA SATYA.....	218
219.	PENILAIAN ANGKA KREDIT JAB FUNG DOSEN.....	219
220.	PENILAIAN ANGKA KREDIT JABATAN FUNGSIONAL DOSEN.....	220
221.	PENILAIAN ANGKA KREDIT JABATAN FUNGSIONAL PLP.....	221
222.	PENILAIAN PRESTASI KERJA PEGAWAI.....	222
223.	KENAIKAN PANGKAT REGULER.....	223
224.	PEMBUATAN SURAT KETERANGAN KERJA.....	224
225.	KENAIKAN PANGKAT JABATAN FUNGSIONAL PLP.....	225
226.	KENAIKAN PANGKAT JABATAN FUNGSIONAL TERTENTU PLP.....	226
227.	KENAIKAN PANGKAT PILIHAN PNS YANG MENDUDUKI JABATAN STRUKTURAL.....	227
228.	KENAIKAN PANGKAT PILIHAN PNS YANG MENDUDUKI JABATAN FUNGSIONAL TERTENTU 228	
229.	KEUANGAN.....	229
230.	PENERIMAAN.....	230
231.	PENERIMAAN PNBPN.....	231
232.	PENGELUARAN.....	232
233.	PELAYANAN PAJAK.....	233
234.	PENGAJUAN HONOR PNBPN.....	234
235.	PENCAIRAN DANA GUP.....	235
236.	PENCAIRAN DANA LS.....	236
237.	PENCAIRAN DANA SPPD.....	237
238.	PENCAIRAN DANA GU.....	238
239.	PENCAIRAN DANA UP.....	239
240.	PELAPORAN.....	240
241.	PELAPORAN KEUANGAN.....	241
242.	PELAPORAN PAJAK MASA.....	242
243.	KEAMANAN.....	243
244.	PENGATURAN KEAMANAN.....	244
245.	PENJAGAAN KEAMANAN.....	245
246.	PATROLI.....	246
247.	PENGAWALAN.....	247
248.	HUMAS.....	248

249.	PELAKSANAAN ACARA SEREMONIAL AKADEMIK	249
250.	COMPANY PROFILE	250
251.	UPACARA BENDERA	251
252.	PENANDATANGANAN MOU	252
253.	PERMINTAAN CINDERAMATA	253
254.	LAYANAN TAMU PIMPINAN	254
255.	MEDIA CETAK.....	255
256.	PUBLIKASI DAN PROMOSI.....	256
257.	PENERBITAN WARTA	257
258.	PENDISTRIBUSIAN WARTA.....	258
259.	PROTOKOLER DAN PELAYANAN MASYARAKAT	259
260.	LAYANAN INFORMASI VIA EMAIL HUMAS.....	260
261.	LAYANAN INFROMASI VIA TELEPON	261
262.	LAYANAN KUNJUNGAN KE POLBAN	262
263.	LAYANAN PENGADUAN MASYARAKAT VIA LAPOR.....	263
264.	LAYANAN TEKNIS.....	264
265.	UPT PERPUSTAKAAN	265
266.	BEBAS MASALAH PERPUSTAKAAN	266
267.	PEMINJAMAN BUKU	267
268.	PENGEMBALIAN BUKU	268
269.	PENGGUNAAN RUANG AKSES DIGITAL.....	269
270.	PENGGUNAAN RUANGAN TELECONFERENCE	270
271.	PERPANJANGAN KEANGGOTAAN	271
272.	REFERENSI BUKU PUSTAKA.....	272
273.	UPT. KOMPUTER (UPTK)	273
274.	PELAYANAN KEGIATAN UPTK.....	274
275.	PEMELIHARAAN DAN PERBAIKAN ALAT LAB UPTK.....	275
276.	PENGGUNAAN LAB RUTIN UPTK.....	276
277.	PENGUNAAN LAB MANUAL UPTK	277
278.	UPT BAHASA.....	278
279.	PELAYANAN KURSUS BAHASA INGGRIS KELAS CONVERSATION.	279
280.	PELAYANAN KURSUS BAHASA INGGRIS TOEFL	280
281.	UPT STUDIO GAMBAR (SGB).....	281
282.	PELAYANAN KEGIATAN UPT STUDIO GAMBAR	282
283.	PEMELIHARAAN DAN PERBAIKAN ALAT LAB UPT SGB	283
284.	PENGGUNAAN LAB SGB TIDAK RUTIN.....	284

285.	PENGUNAAN LAB SGB RUTIN.....	285
286.	UPT LAYANAN KESEHATAN.....	286
287.	PELAYANAN KESEHATAN PASIEN.....	287
288.	LAYANAN ADMINISTRASI UPT LK.....	288
289.	PEMINJAMAN ALAT UPT LK.....	289
290.	LAYANAN PERAWATAN DAN PEMELIHARAAN.....	290
291.	PEMELIHARAAN DAN PERAWATAN (HARWAT) TAK TERENCANA.....	291
292.	PEMELIHARAAN DAN PERAWATAN (HARWAT) TERENCANA.....	292
293.	PEMELIHARAAN DAN PERBAIKAN ALAT LAB.....	293
294.	PERBAIKAN ALAT DI LABORATORIUM.....	294
295.	PEMINJAMAN SARANA BELAJAR.....	295
296.	PENGOPERASIAN PANEL DISTRIBUSI.....	296
297.	PENGOPERASIAN GENERATOR.....	297
298.	PENGADAAN BARANG DAN JASA – P2K.....	298
299.	PENGADAAN BARANG – P2K.....	299
300.	LELANG TENDER – P2K.....	300
301.	PENGADAAN LANGSUNG – P2K.....	301
302.	E –PURCHASING – P2K.....	302
303.	PENGADAAN KONSTRUKSI – P2K.....	303
304.	TENDER KONSTRUKSI – P2K.....	304
305.	PENGADAAN LANGSUNG KONSTRUKSI – P2K.....	305
306.	PENGADAAN JASA – P2K.....	306
307.	KONSULTAN PERENCANA DAN PENGAWAS – P2K.....	307
308.	JASA LAINNYA – P2K.....	308
309.	UNIT PENGADAAN BARANG & JASA - ULP.....	309
310.	PEMILIHAN PENYEDIAAN BARANG DAN JASA.....	310
311.	E – PURCHASING PENGADAAN BARANG - ULP.....	311
312.	PENGADAAN LANGSUNG - ULP.....	312
313.	PENUNJUKKAN LANGSUNG – ULP.....	313
314.	PROSES TENDER PENGADAAN BARANG DAN JASA - ULP.....	314
315.	TENDER PASCA 1 F- ULP.....	315
316.	TENDER PASCA 2 F- ULP.....	316
317.	TENDER CEPAT- ULP.....	317
318.	PENGADAAN JASA KONSULTANSI - ULP.....	318
319.	PENGADAAN LANGSUNG KONSULTANSI.....	319
320.	PENUNJUKKAN LANGSUNG KONSULTANSI.....	320

1. PETA PROSES BISNIS POLBAN



2. PENGEMBANGAN PENDIDIKAN

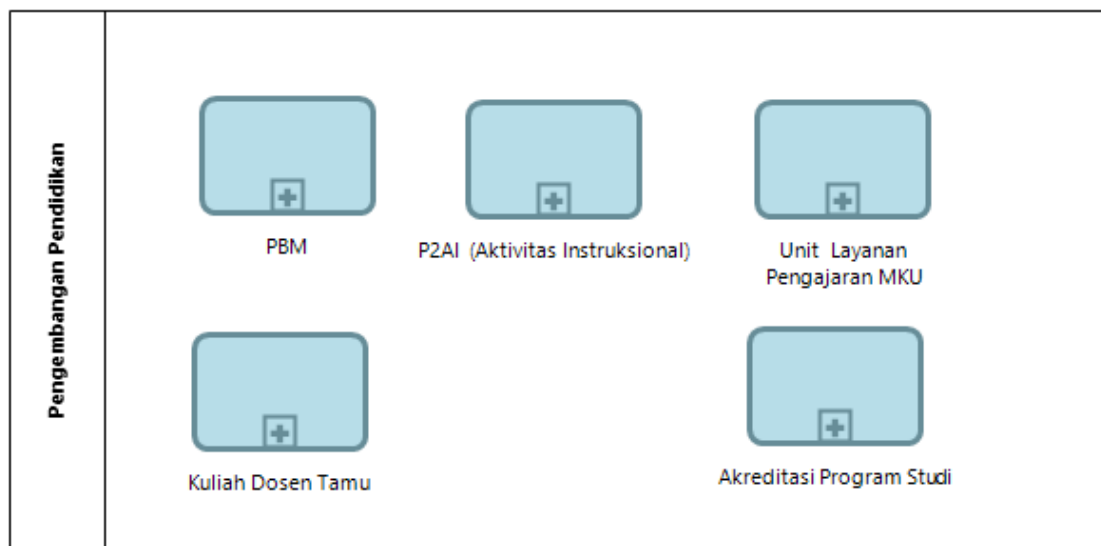

Powered by
bizagi
Modeler

3. PROSES BELAJAR MENGAJAR

Proses Belajar Mengajar	 <p>Seleksi Mahasiswa Baru</p>
--------------------------------	---



4. SELEKSI MAHASISWA BARU

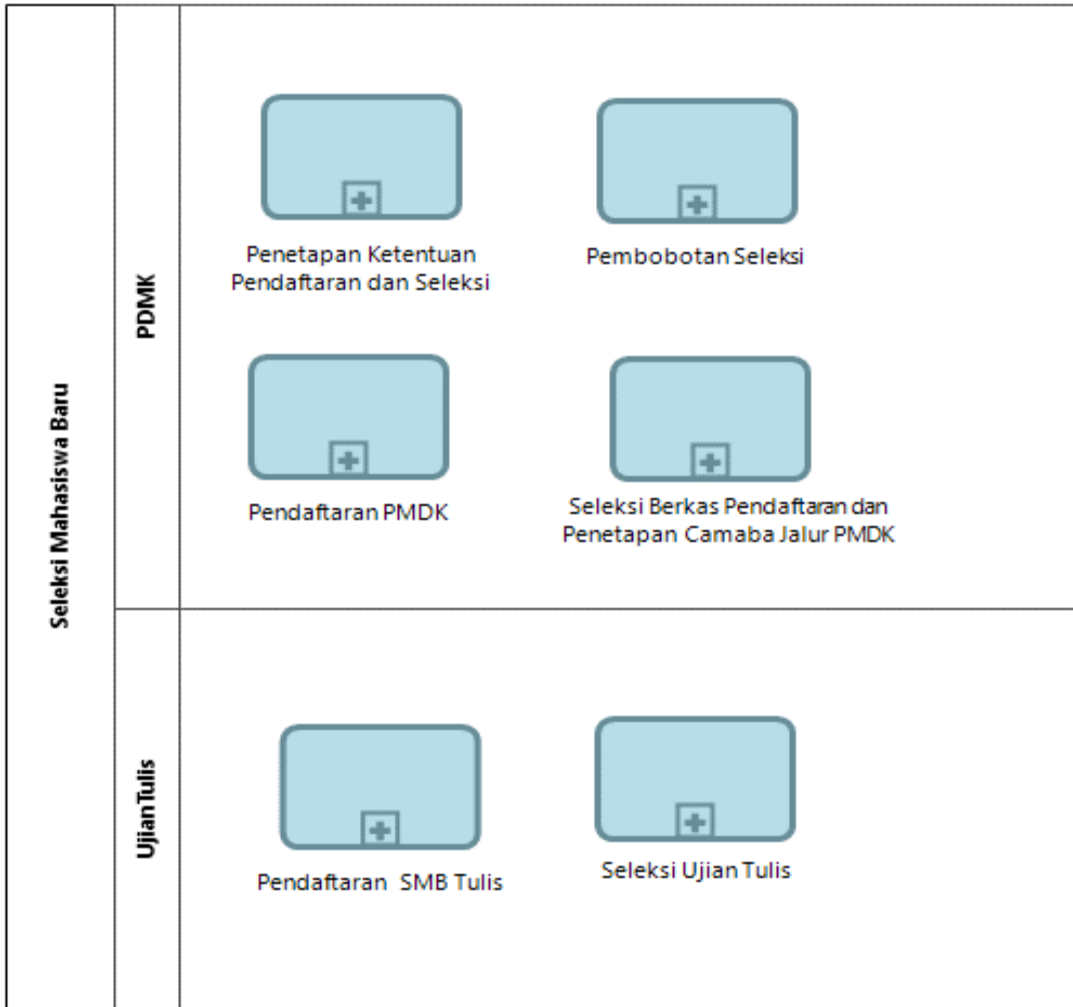

5. PENETAPAN KETENTUAN PENDAFTARAN DAN SELEKSI

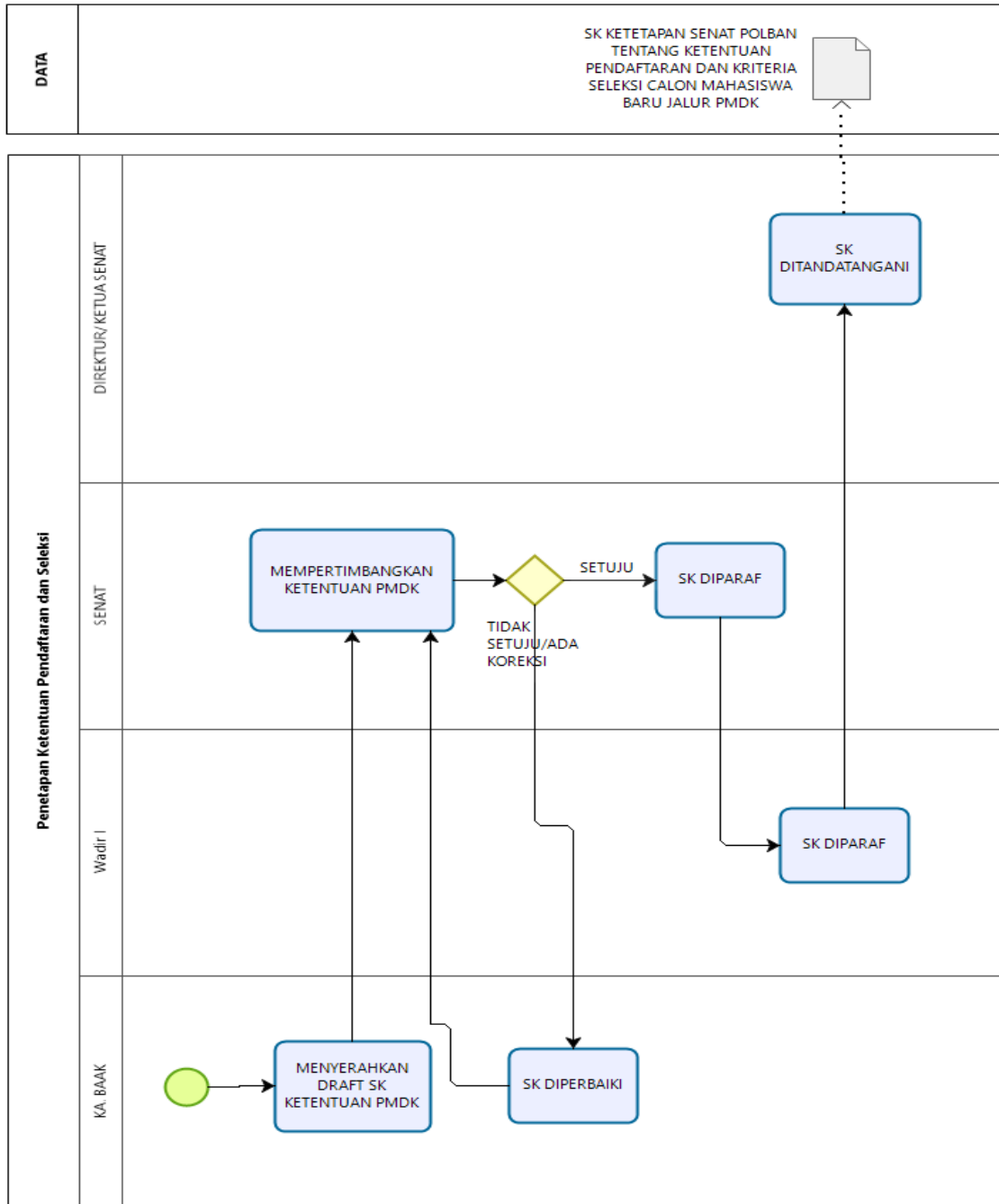

6. PEMBOBOTAN DAN SELEKSI

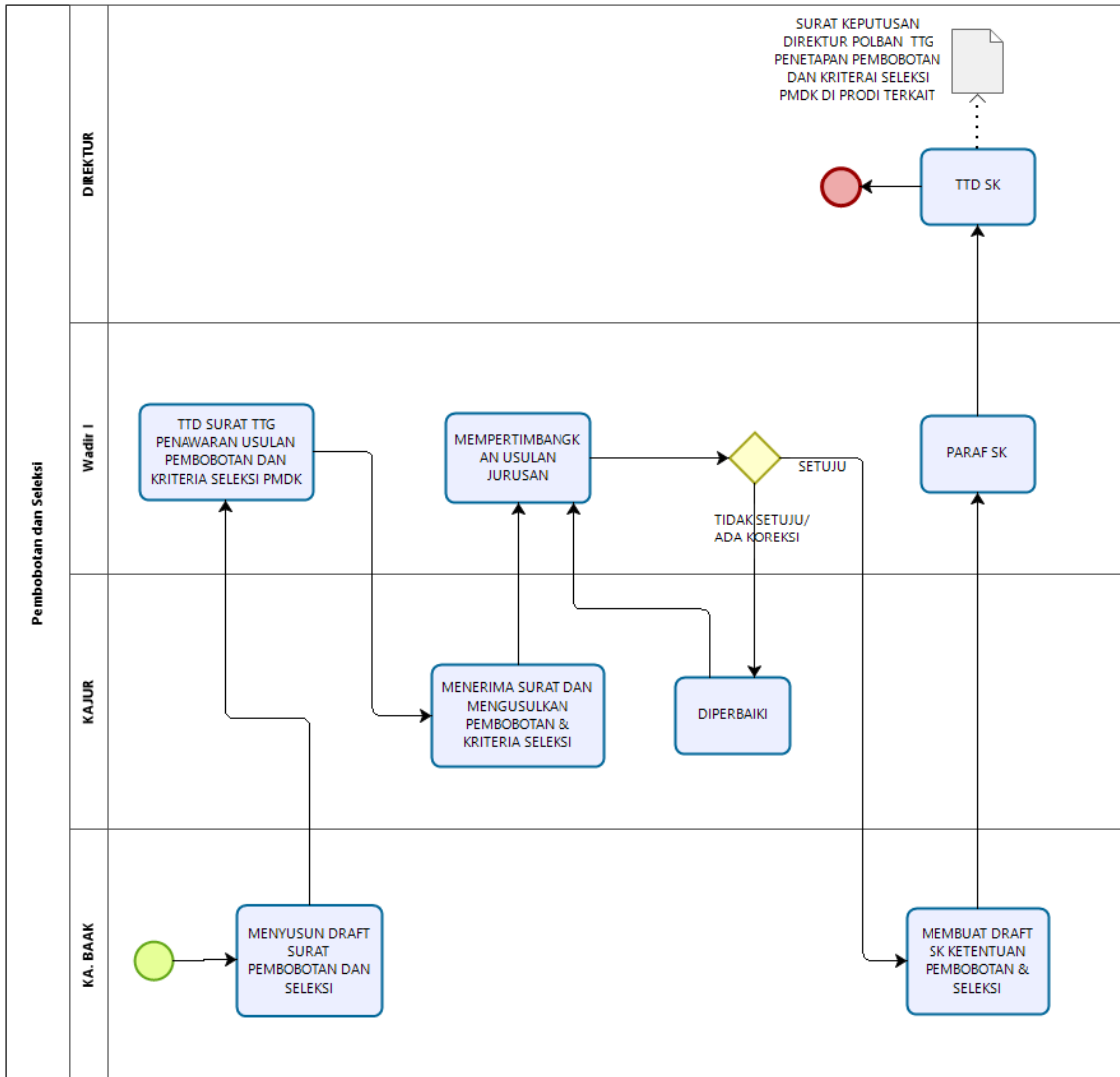

7. PENDAFTARAN PMDK

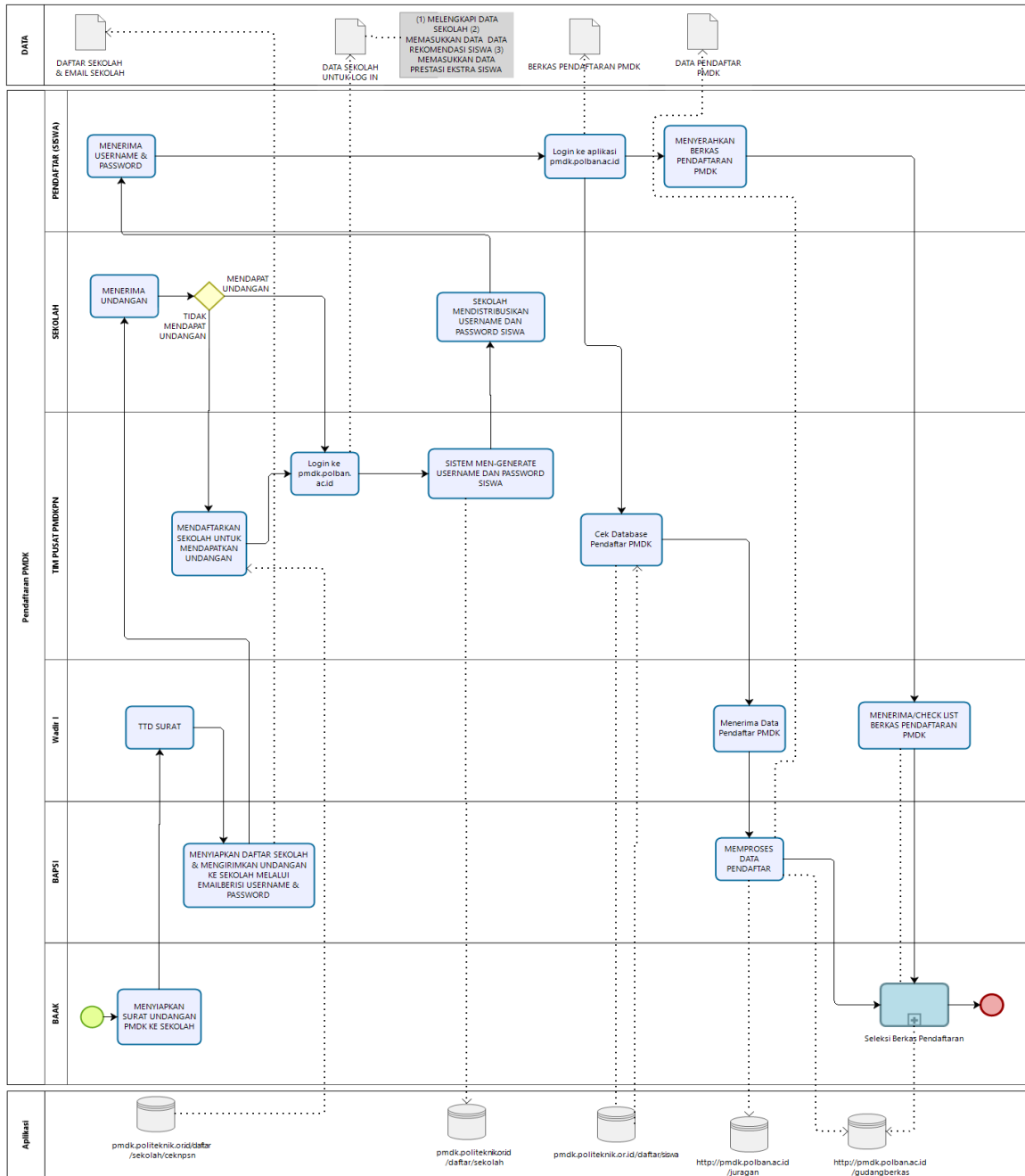

8. SELEKSI BERKAS PENDAFTARAN DAN PENETAPAN CAMABA JALUR PMDK

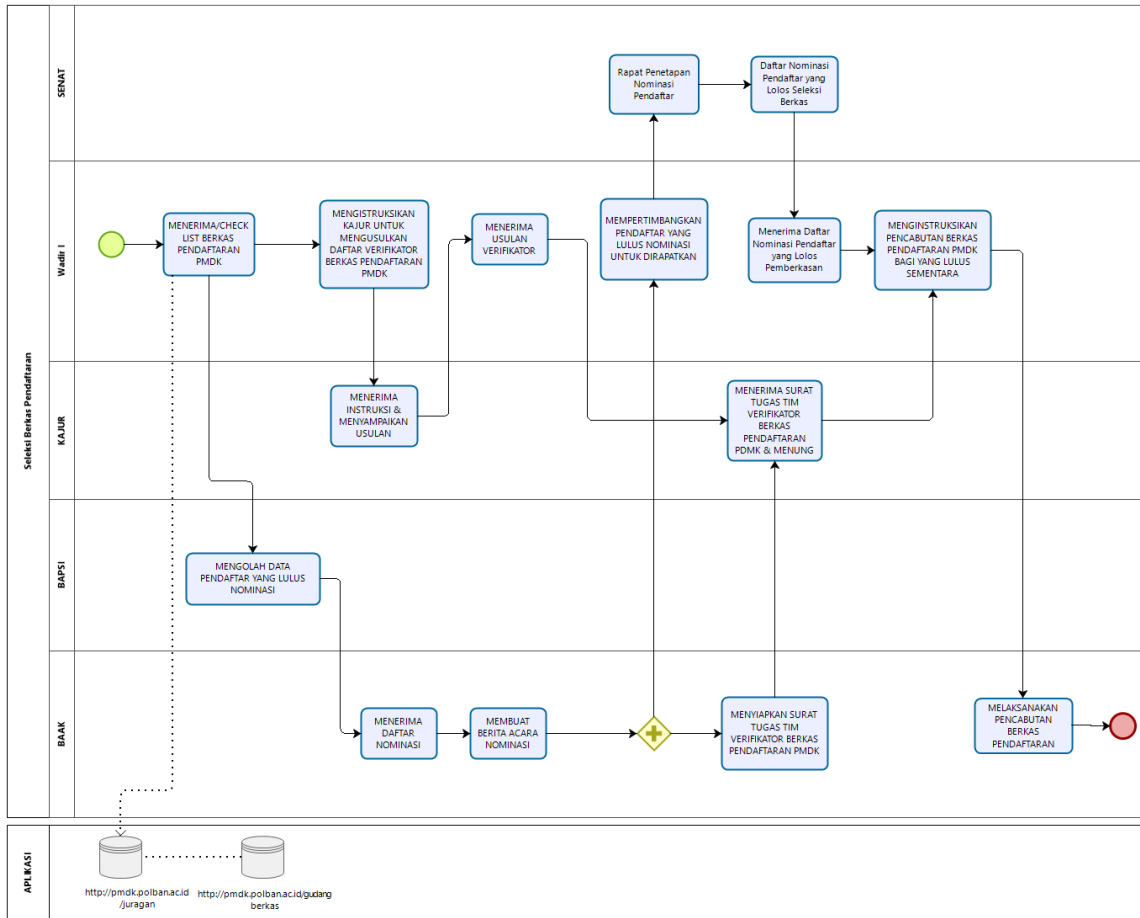

9. PENDAFTARAN SMB TULIS

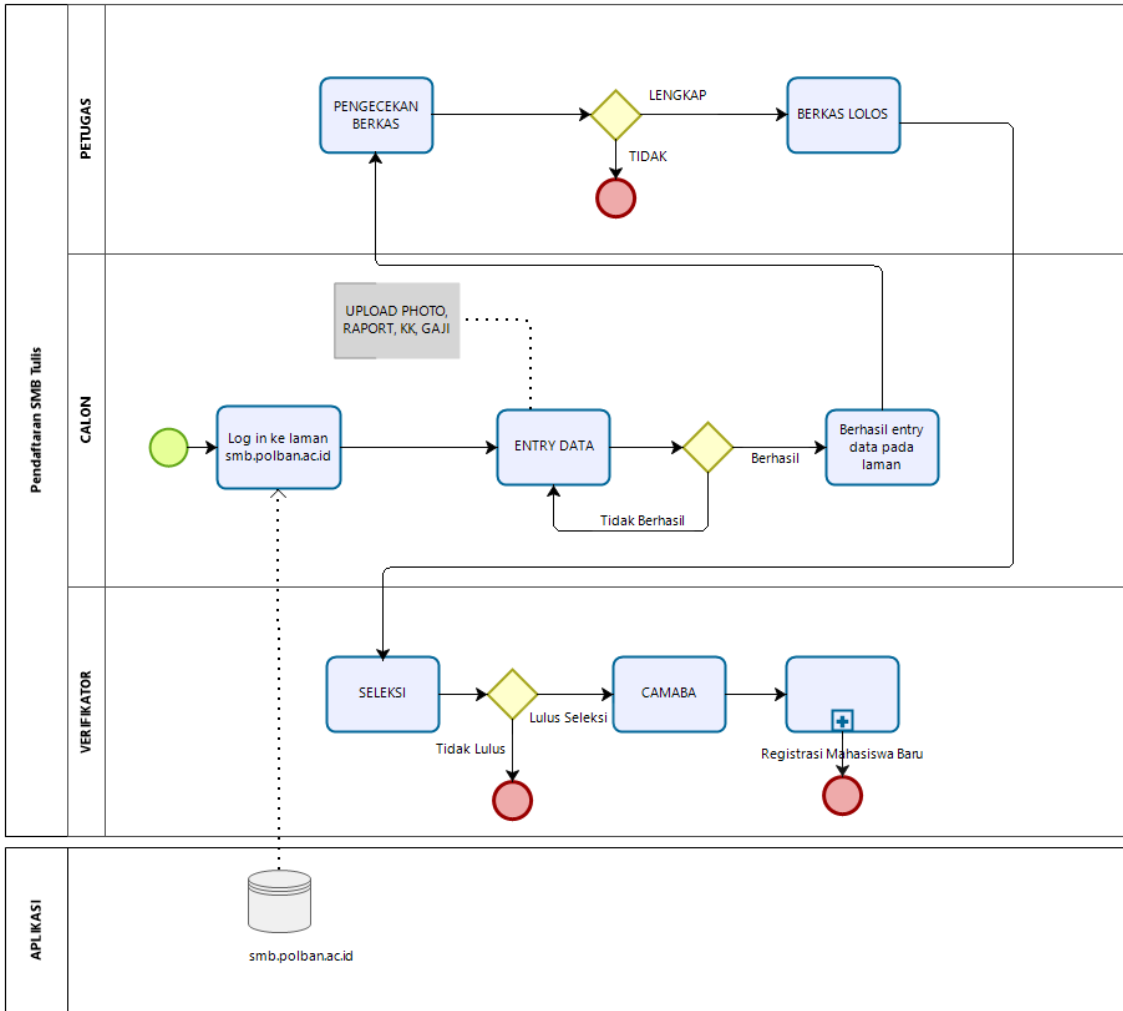

10. SELEKSI UJIAN TULIS

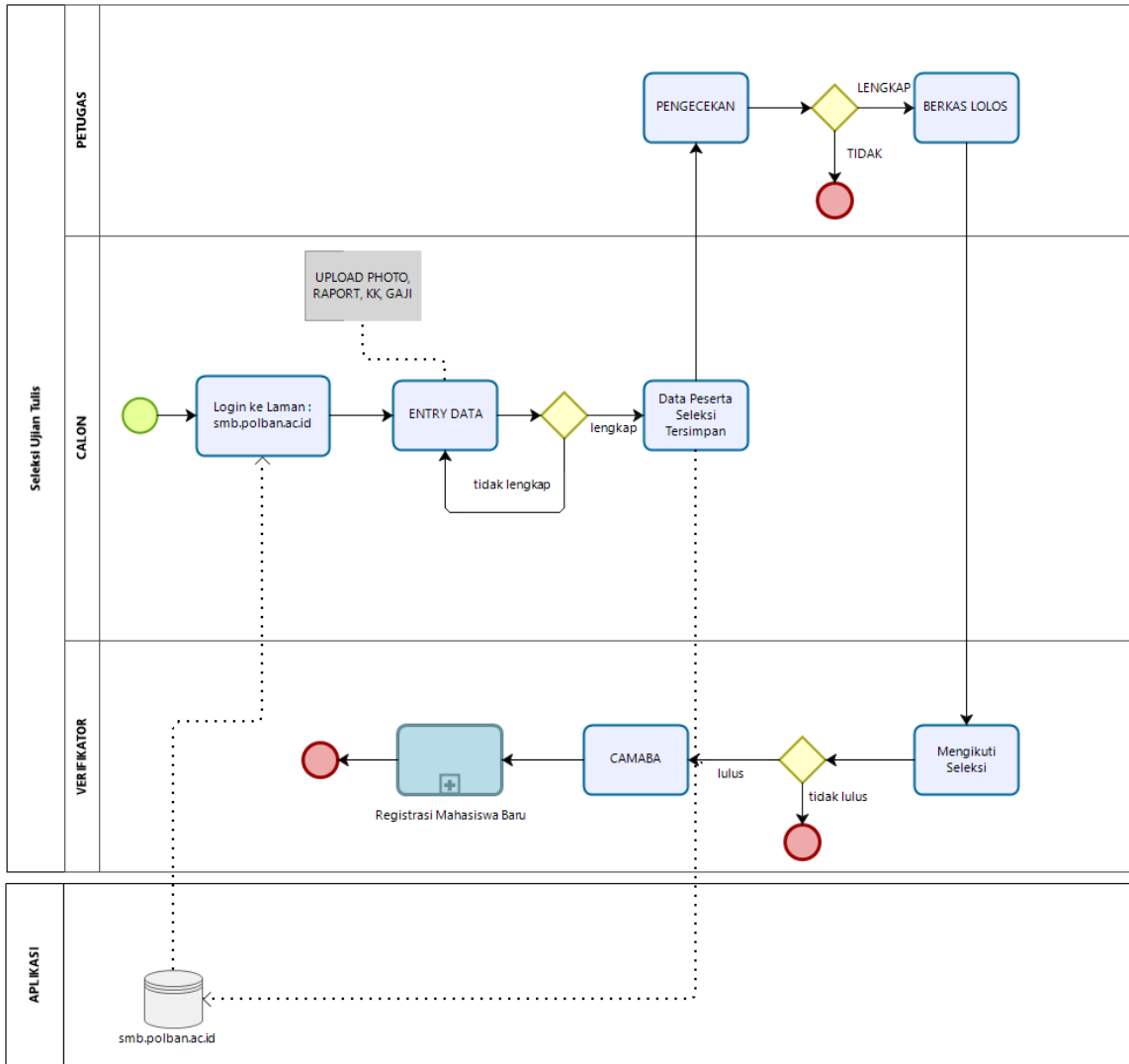

11. P2AI (AKTIVITAS INSTRUKSIONAL)



12. KURIKULUM

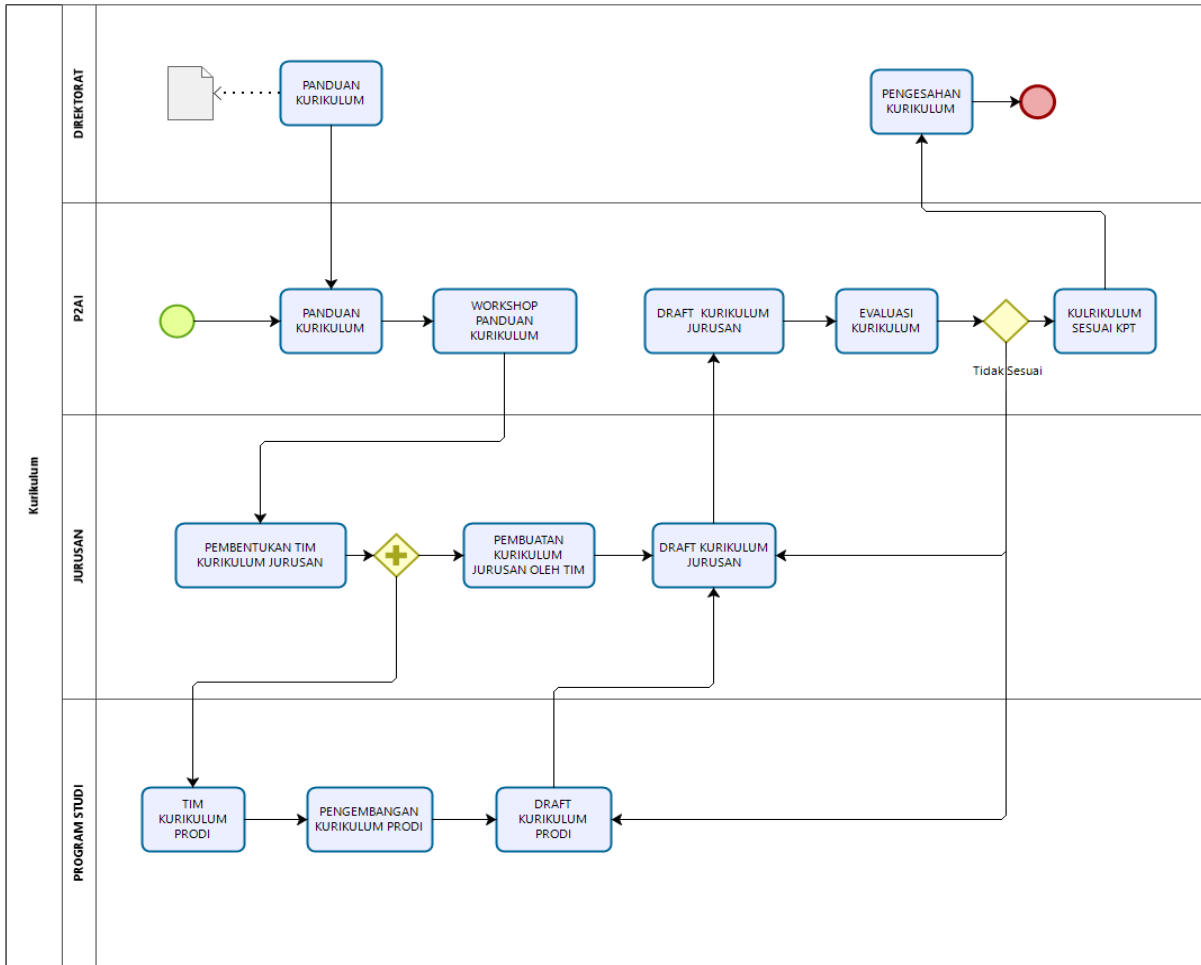

13. RENCANA PEMBELAJARAN SEMESTER

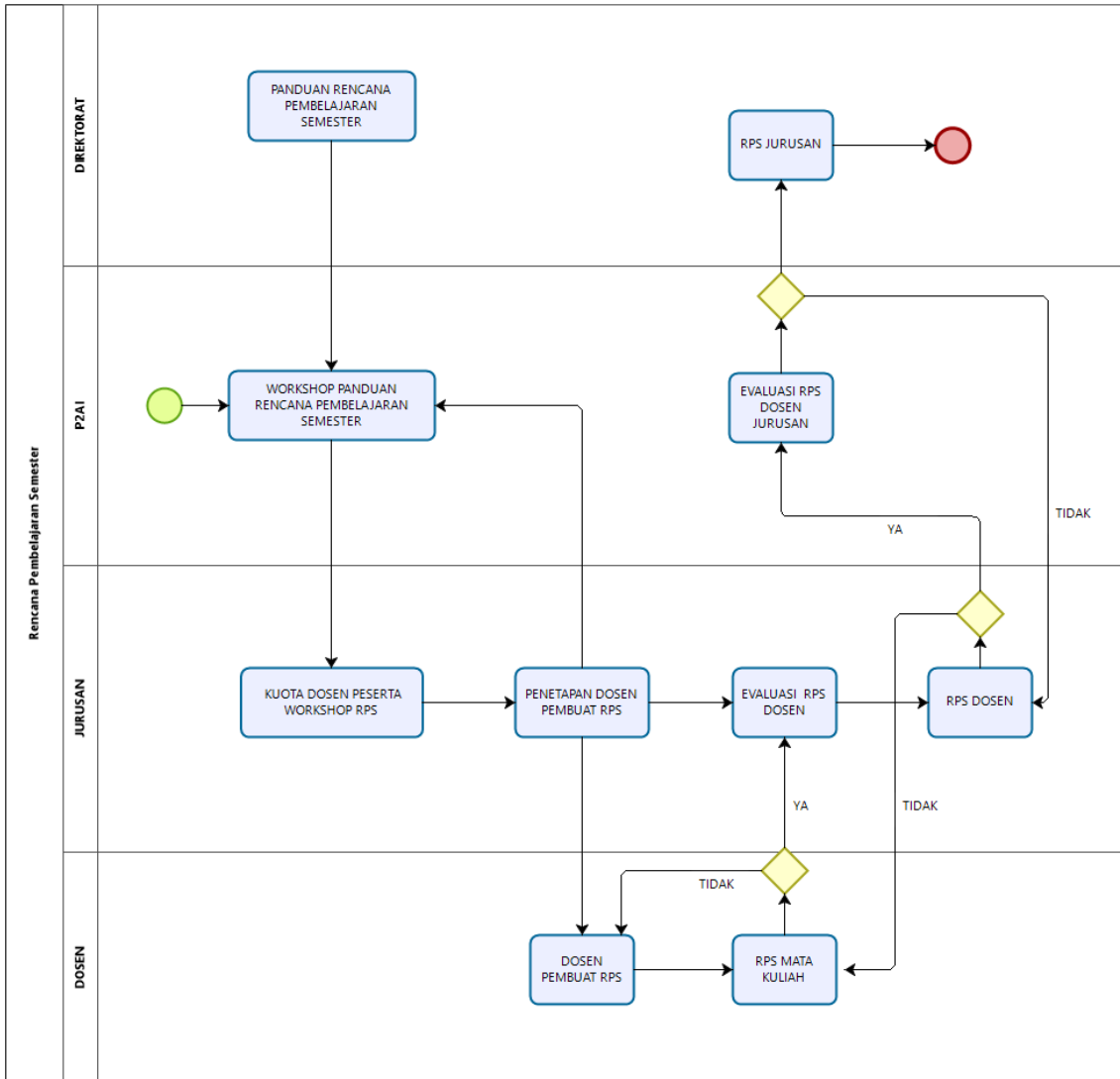

14. E-LEARNING

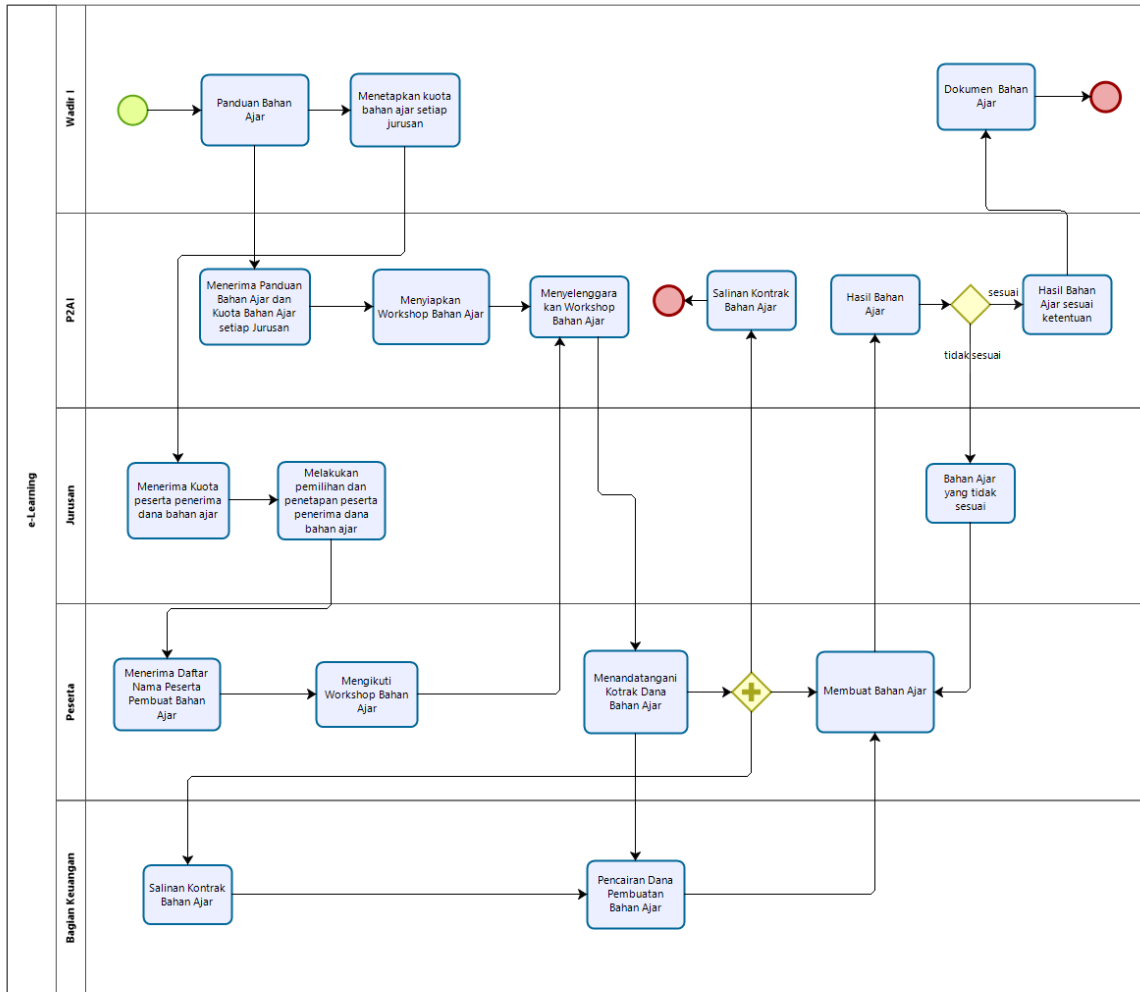

Powered by bizagi Modeler

15. METODOLOGI PEMBELAJARAN

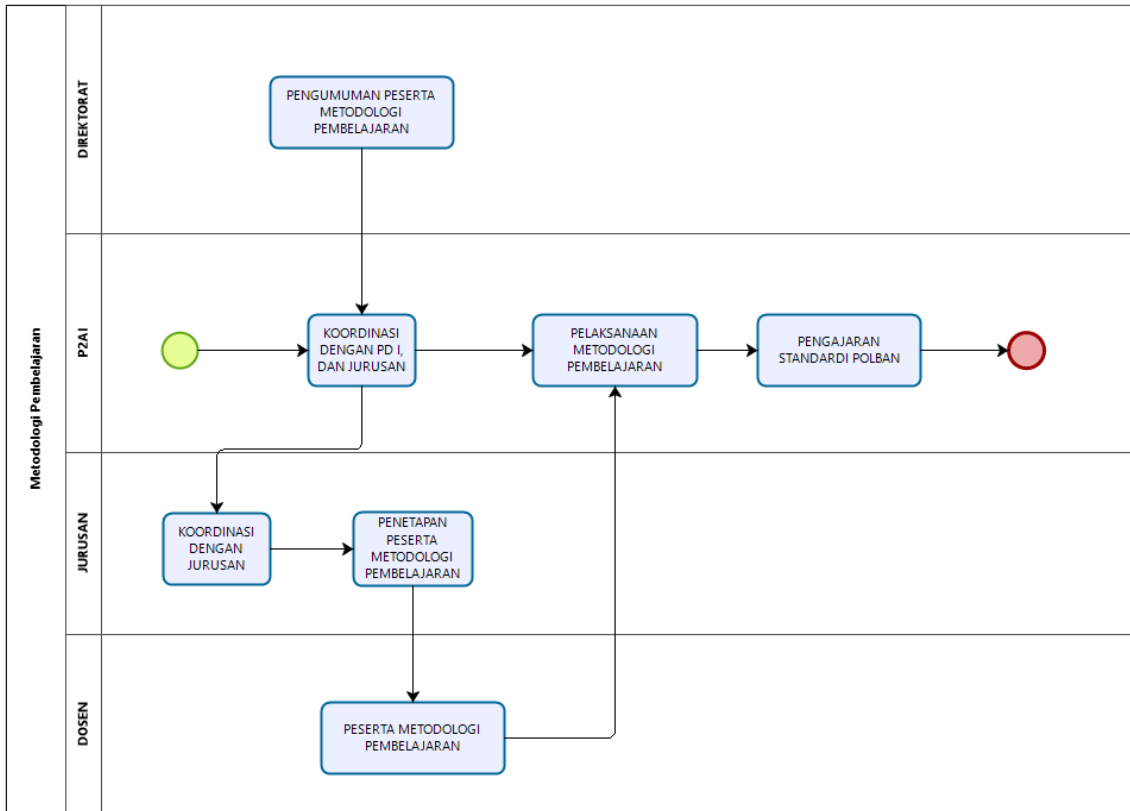

16. METODOLOGI PENGAJARAN

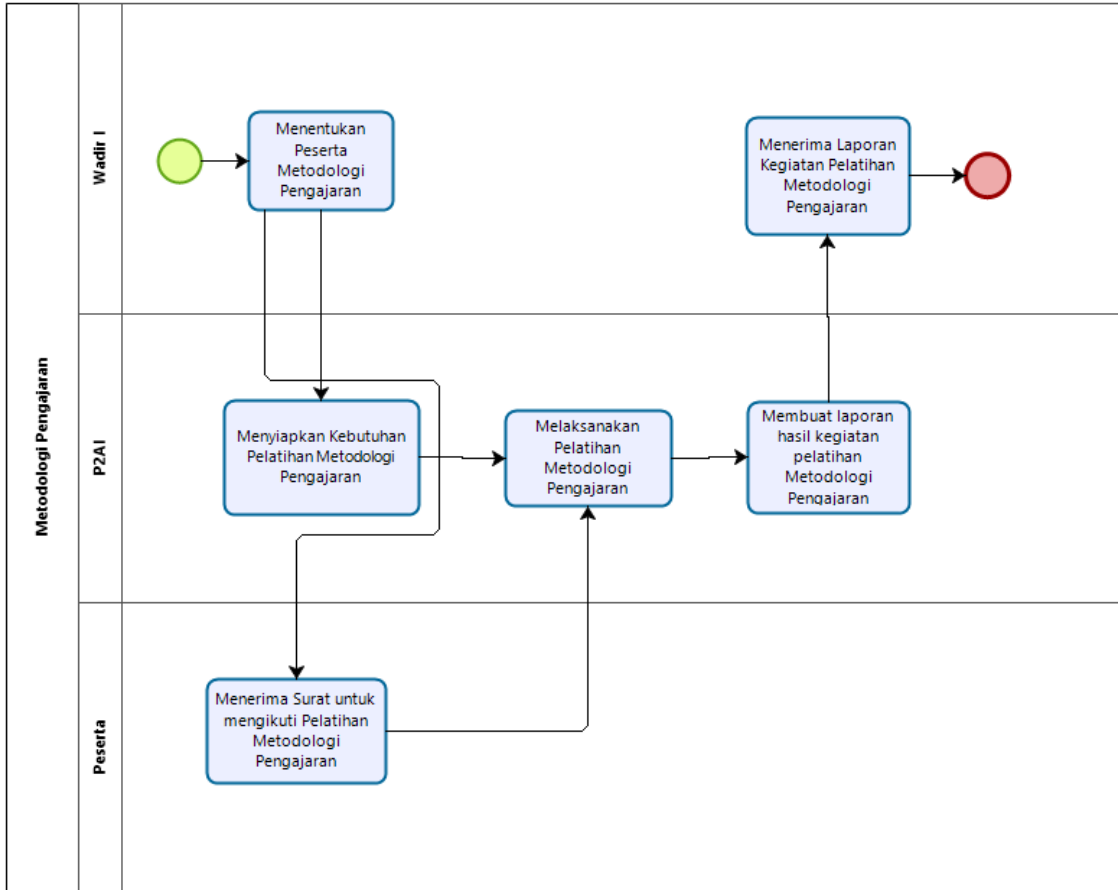

17. UP. MKU

UP. MKU	<div style="display: flex; justify-content: space-around; align-items: center;"><div style="text-align: center;"> Bimbingan Belajar (BIMBEL)</div><div style="text-align: center;"> Penerbitan Jurnal SIGMAMU</div></div>
----------------	---

Powered by
bizagi
Modeler

18. BIMBINGAN BELAJAR (BIMBEL)

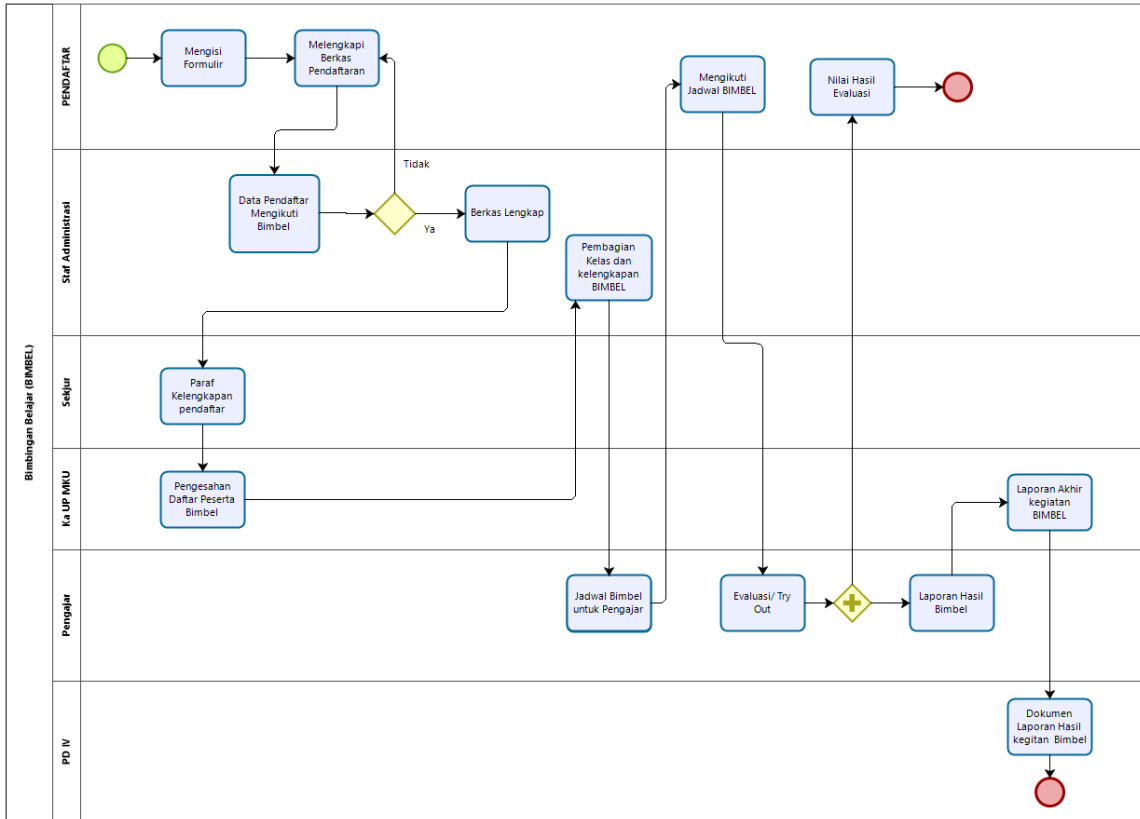

19. PENERBITAN JURNAL SIGMAMU

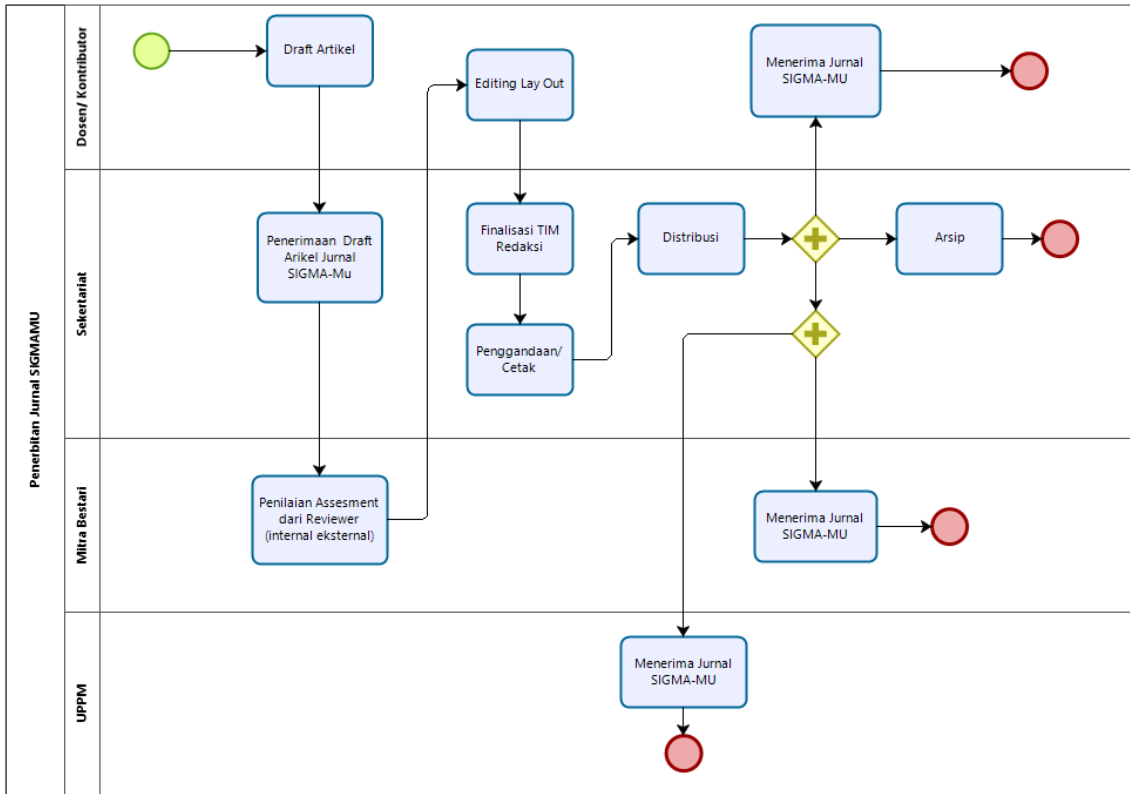

20. KULIAH DOSEN TAMU

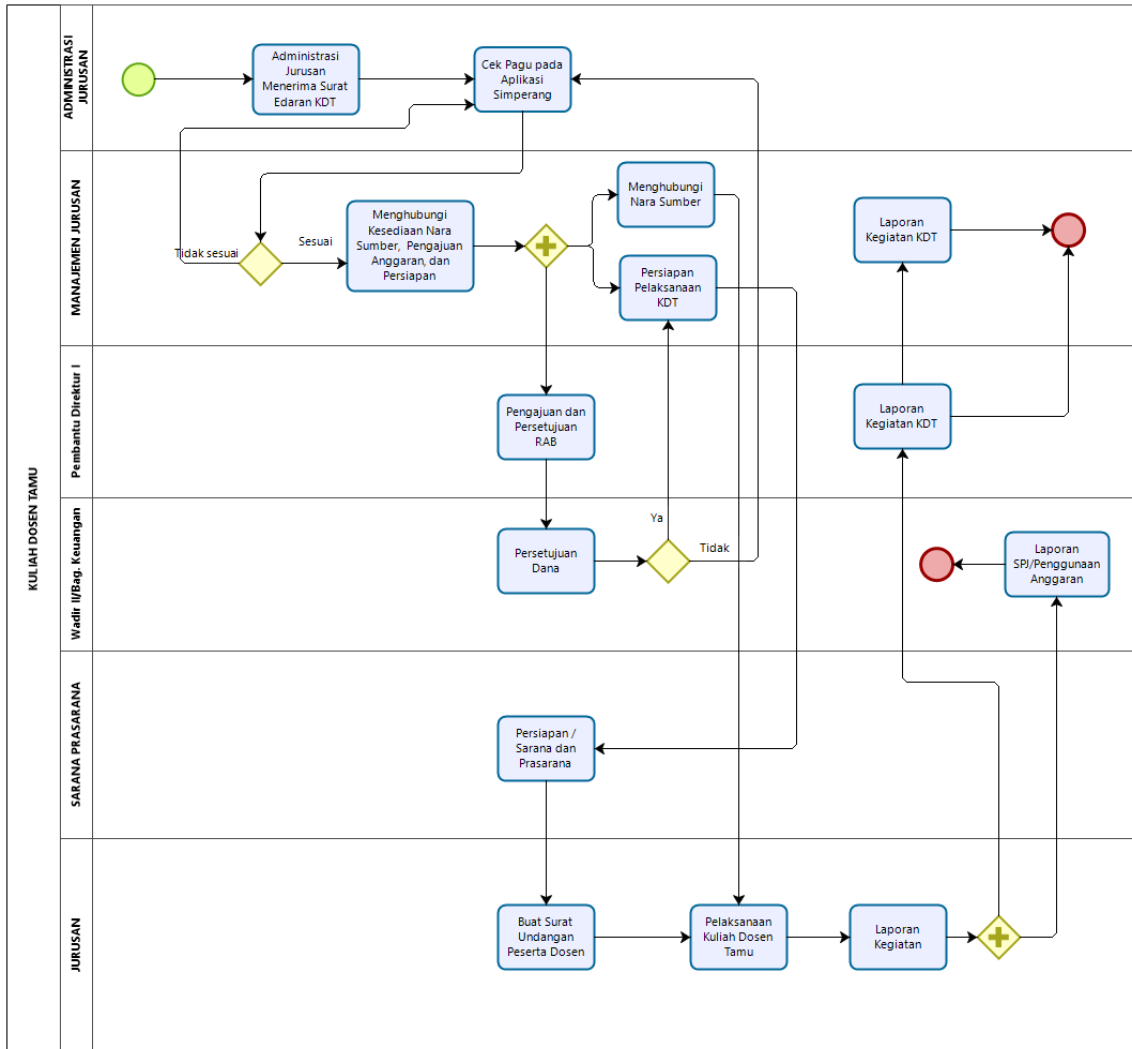

Powered by bizagi Modeler

21. AKREDITASI PROGRAM STUDI

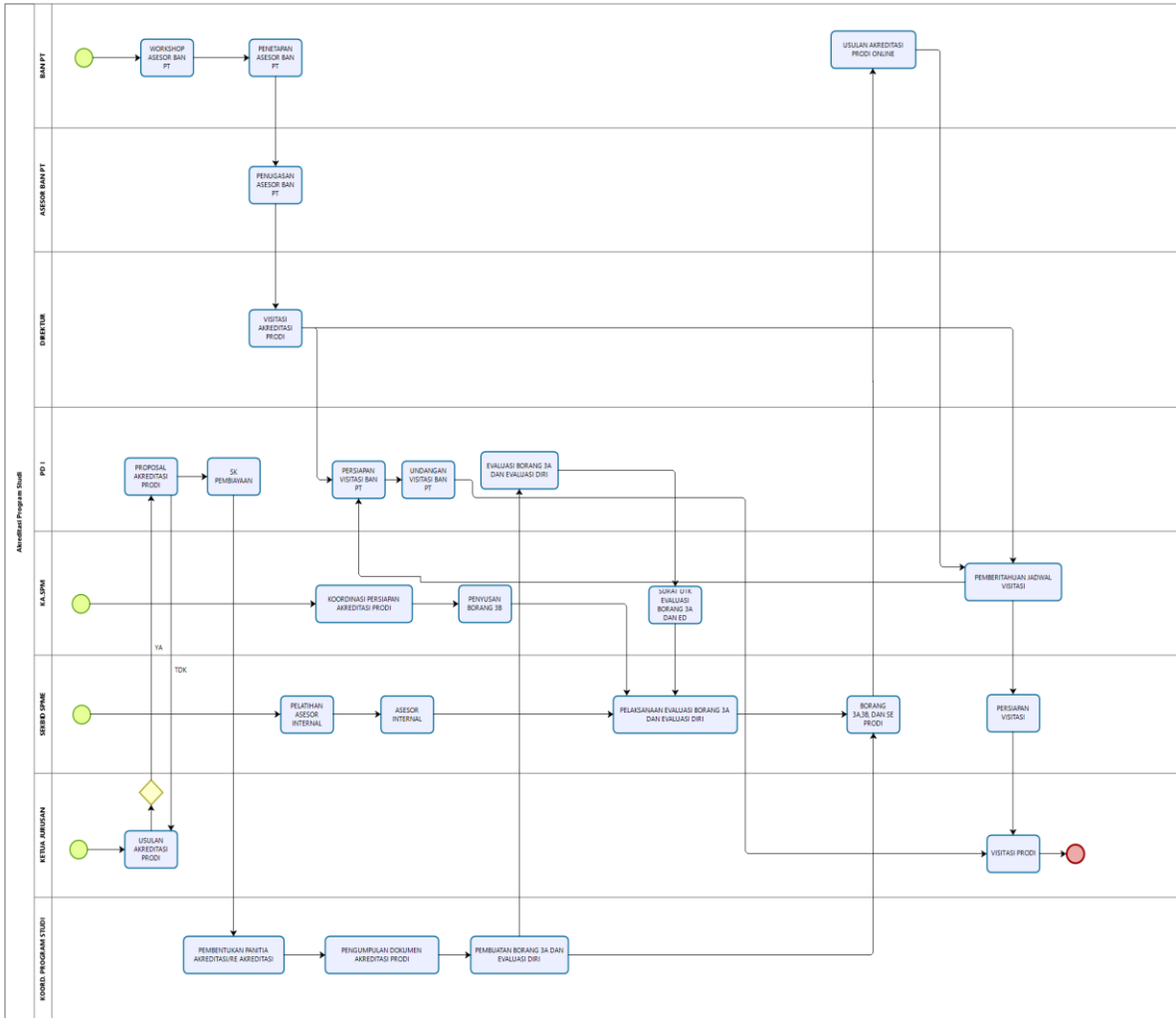

22. PENELITIAN PENDIDIKAN

Penelitian Pendidikan	 <p>Penelitian Berbasis Riset</p>
------------------------------	--

Powered by
bizagi
Modeler

23. PENELITIAN BERBASIS RISET

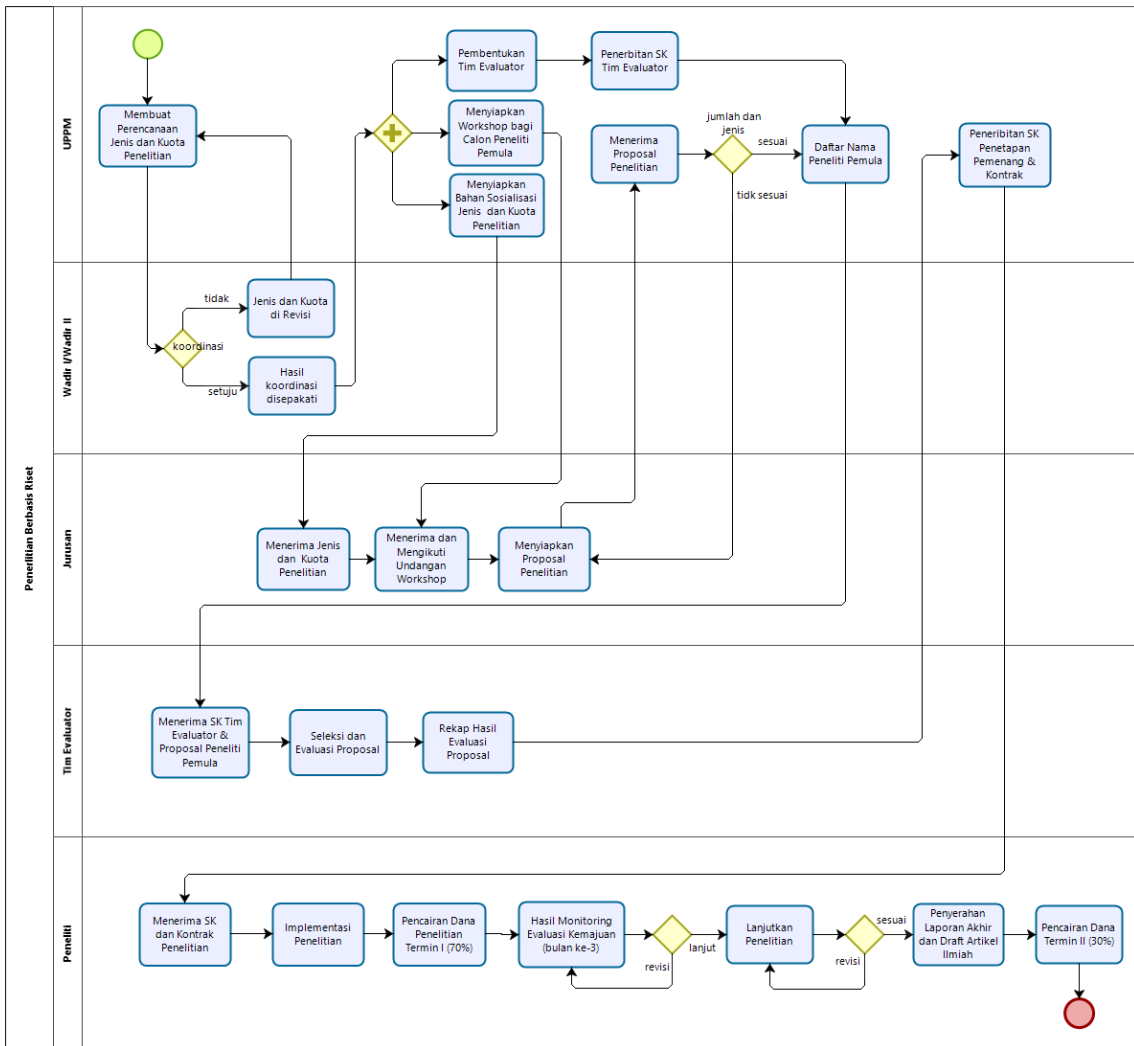

24. PENGABDIAN KEPADA MASYARAKAT



25. PKM KERJASAMA

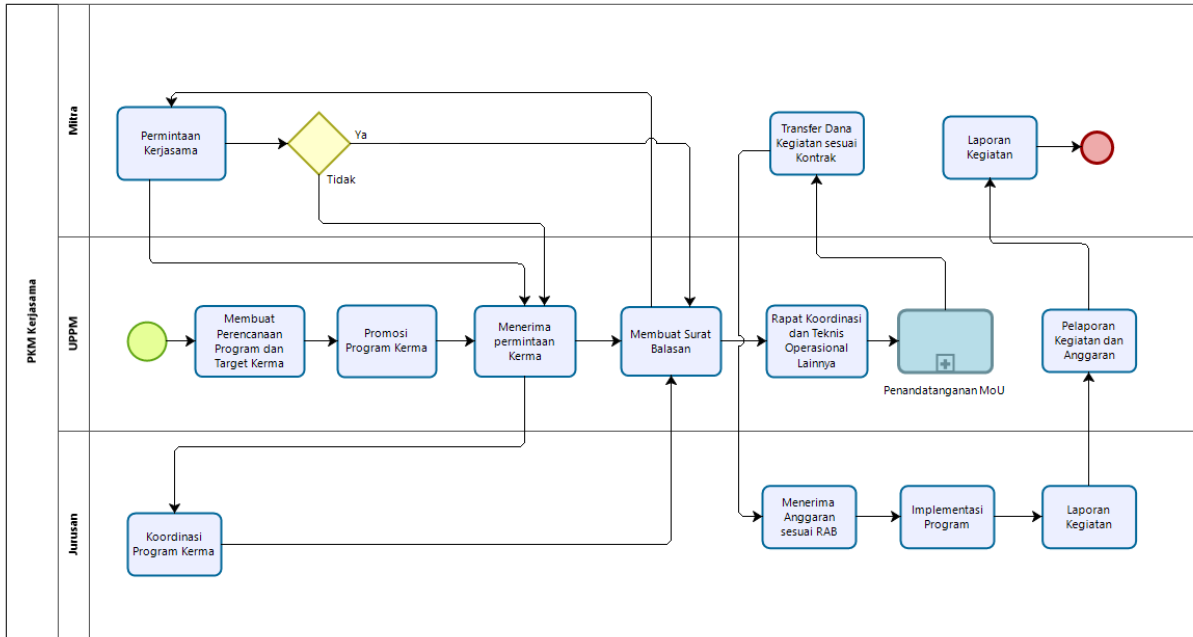

Powered by
bizagi
Modeler

26. PEMBINAAN SIVITAS AKADEMIKA



27. PEMBINAAN TENAGA KEPENDIDIKAN

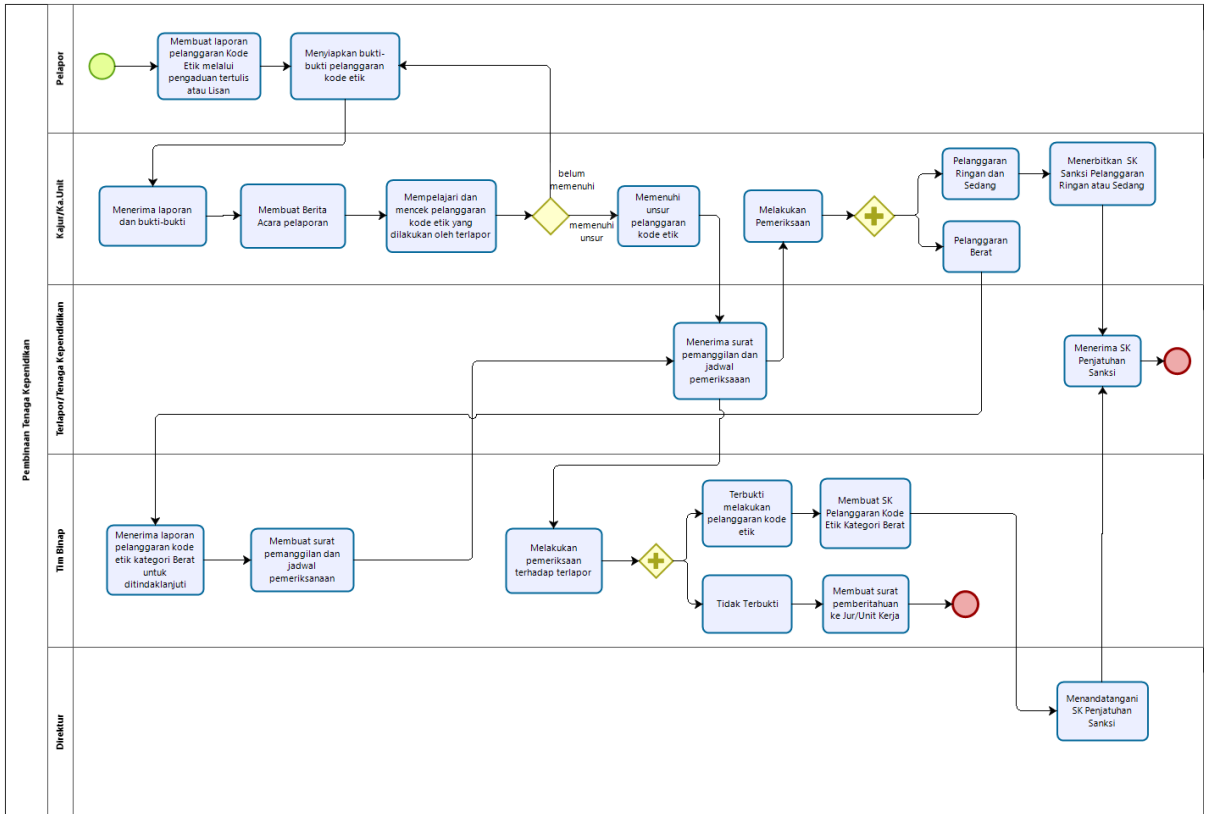

28. PEMBINAAN TENAGA PENDIDIK/DOSEN

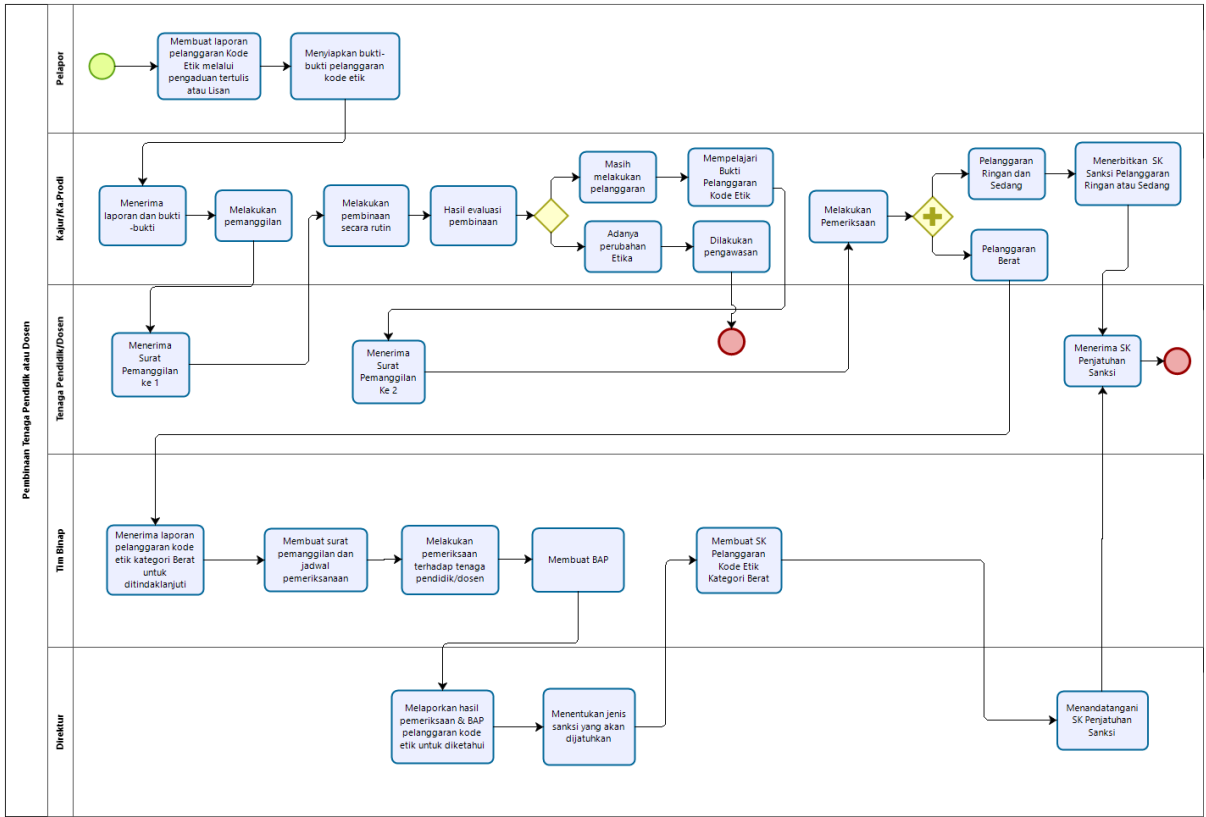

29. SATUAN PENJAMINAN MUTU



30. AUDIT MUTU INTERNAL

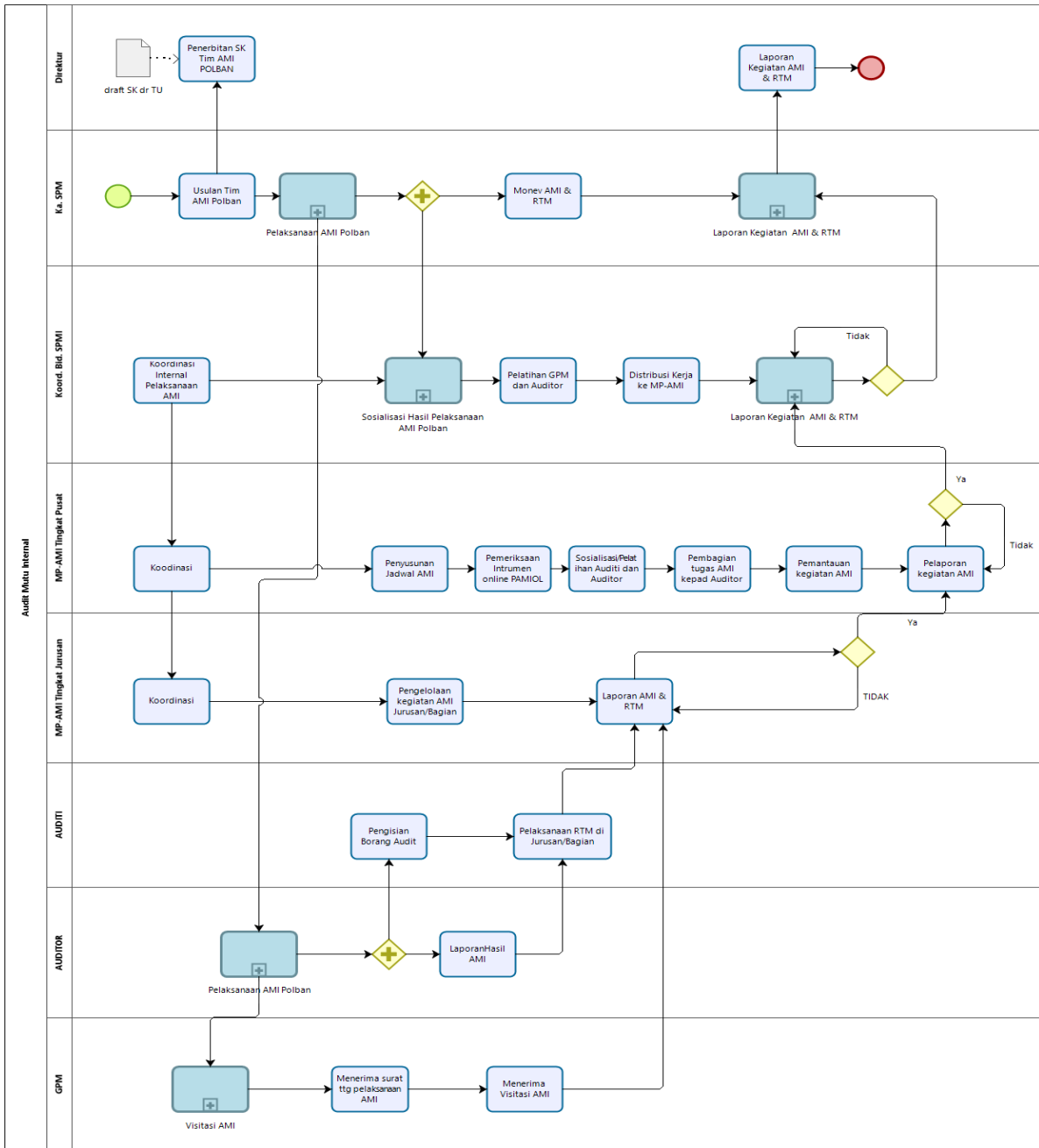

Powered by bizagi Modeler

31. PELAKSANAAN AMI POLBAN

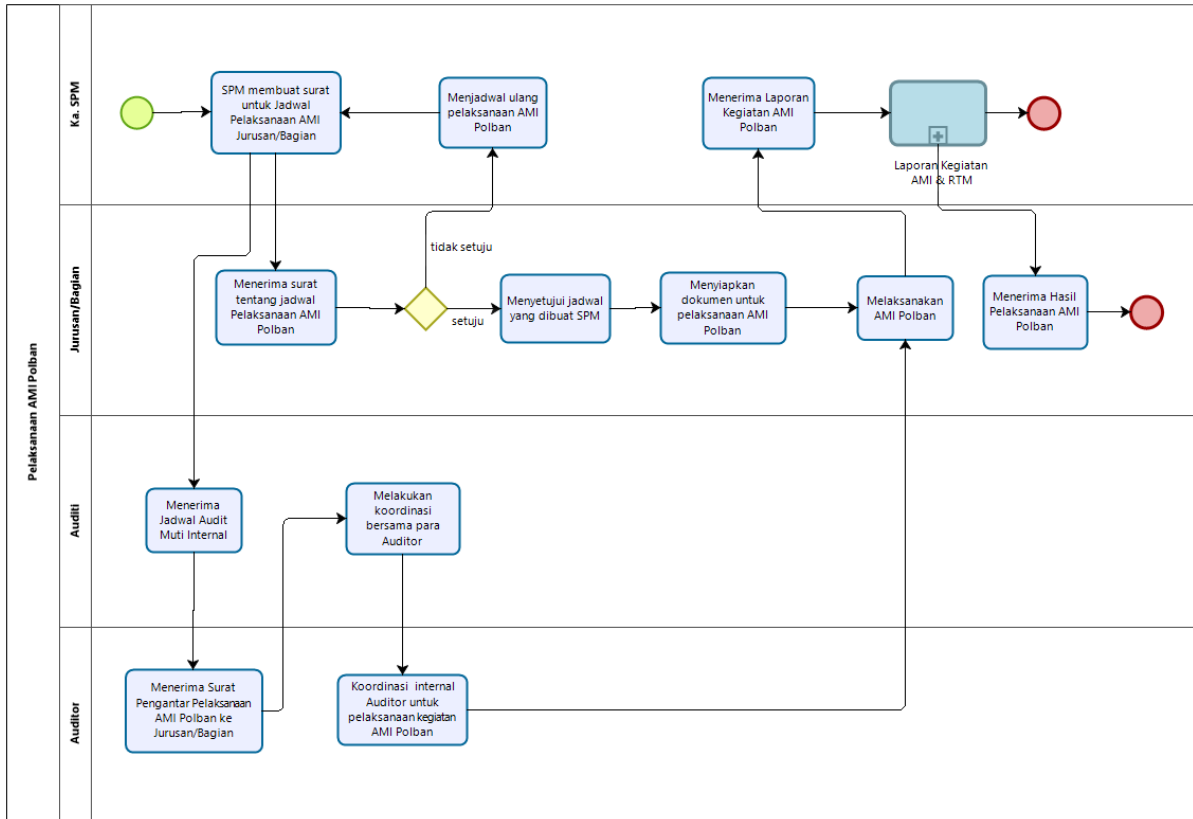

32. SOSIALISASI HASIL PELAKSANAAN AMI POLBAN

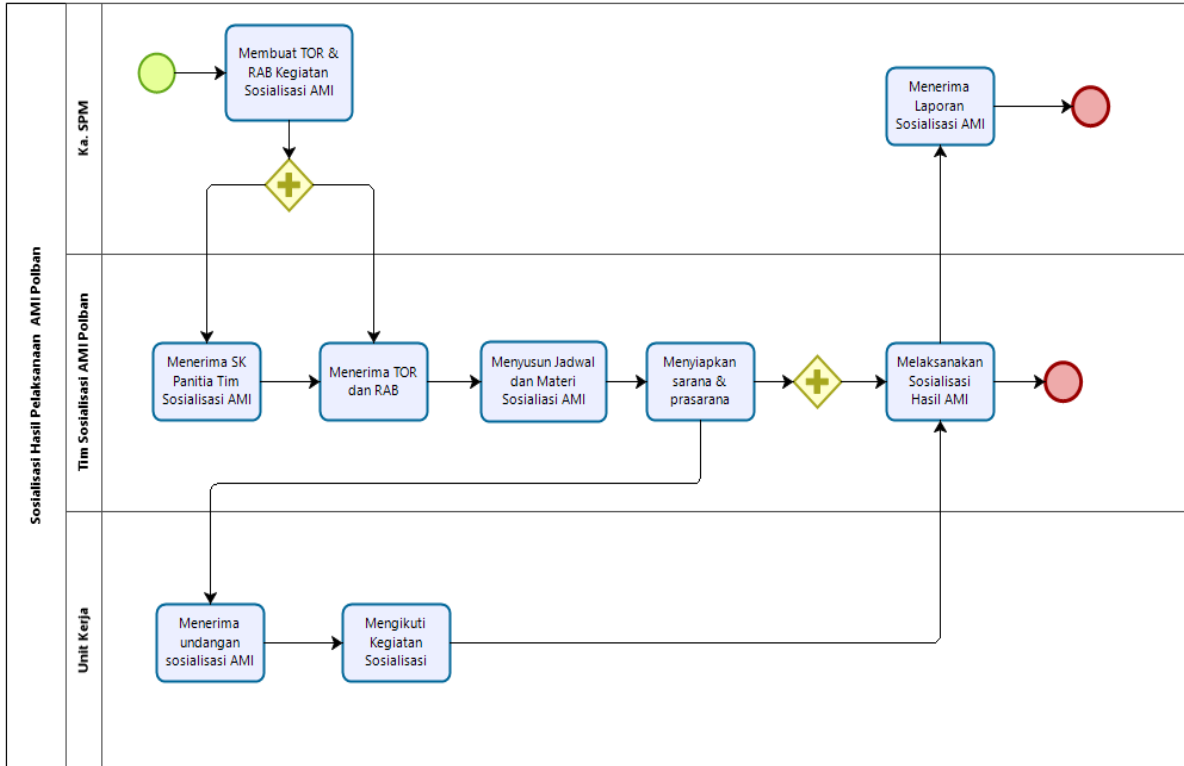

33. VISITASI AMI

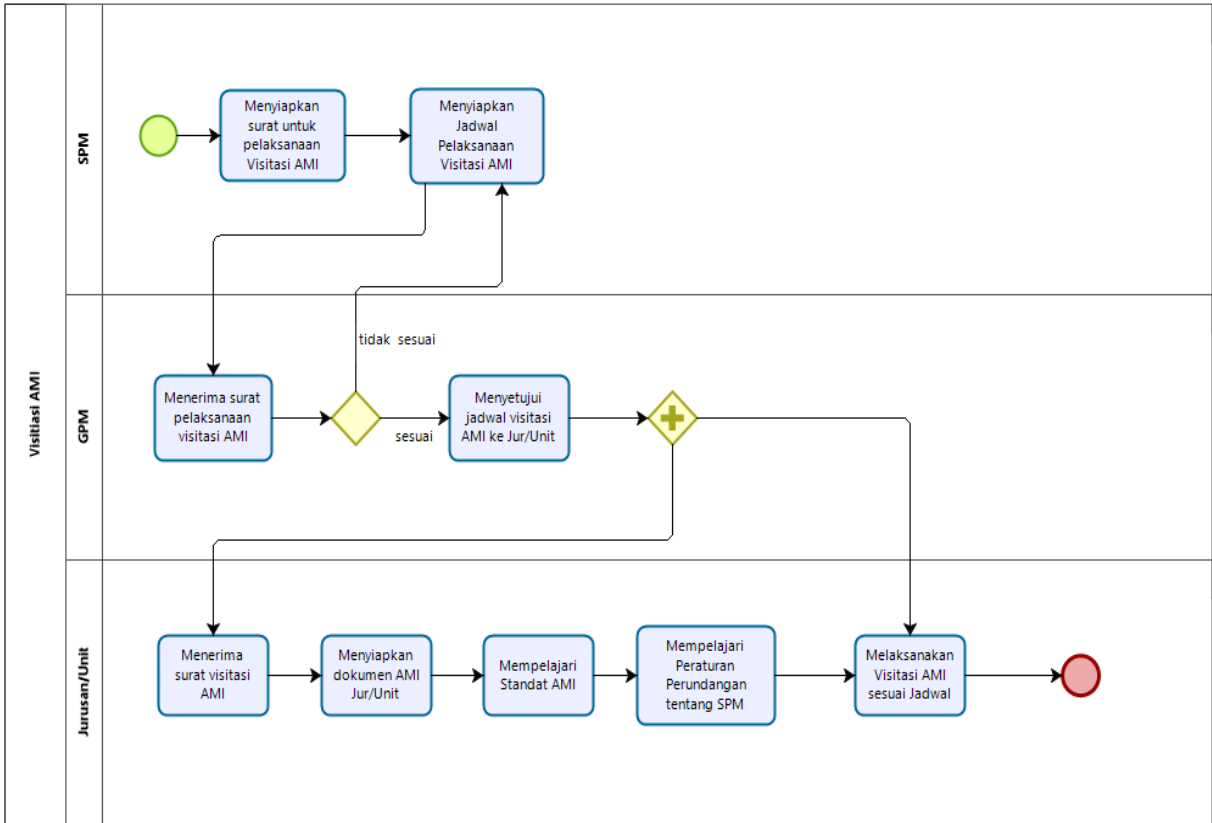

34. LAPORAN KEGIATAN AMI & RTM

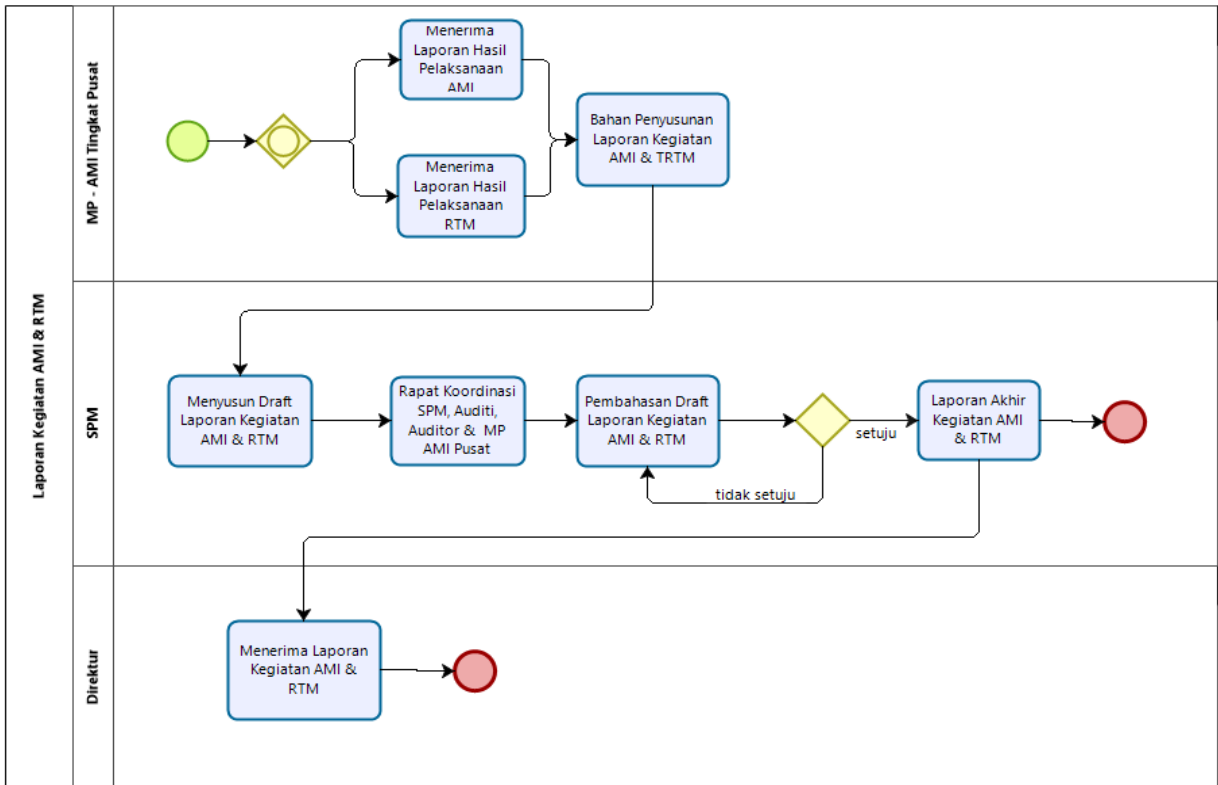

35. SATUAN PENGAWASAN INTERNAL

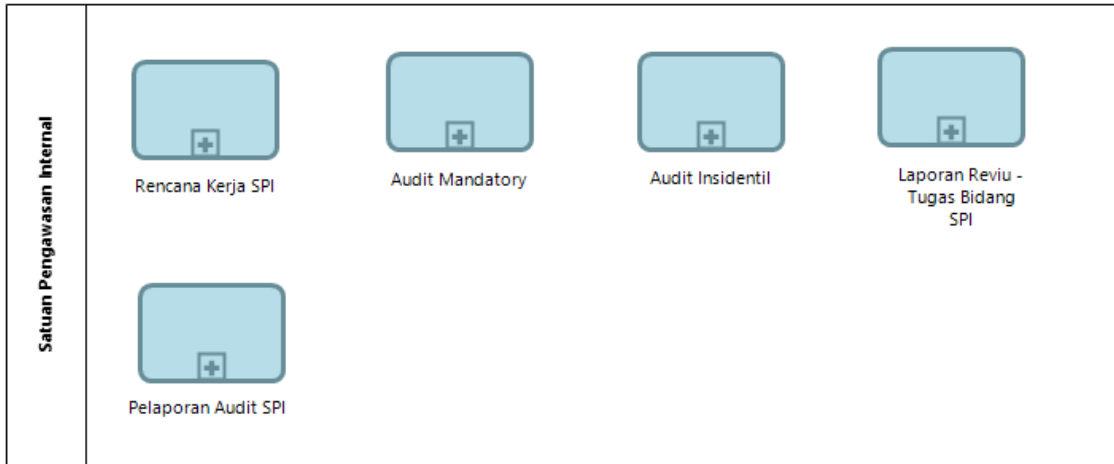

36. RENCANA KERJA SPI

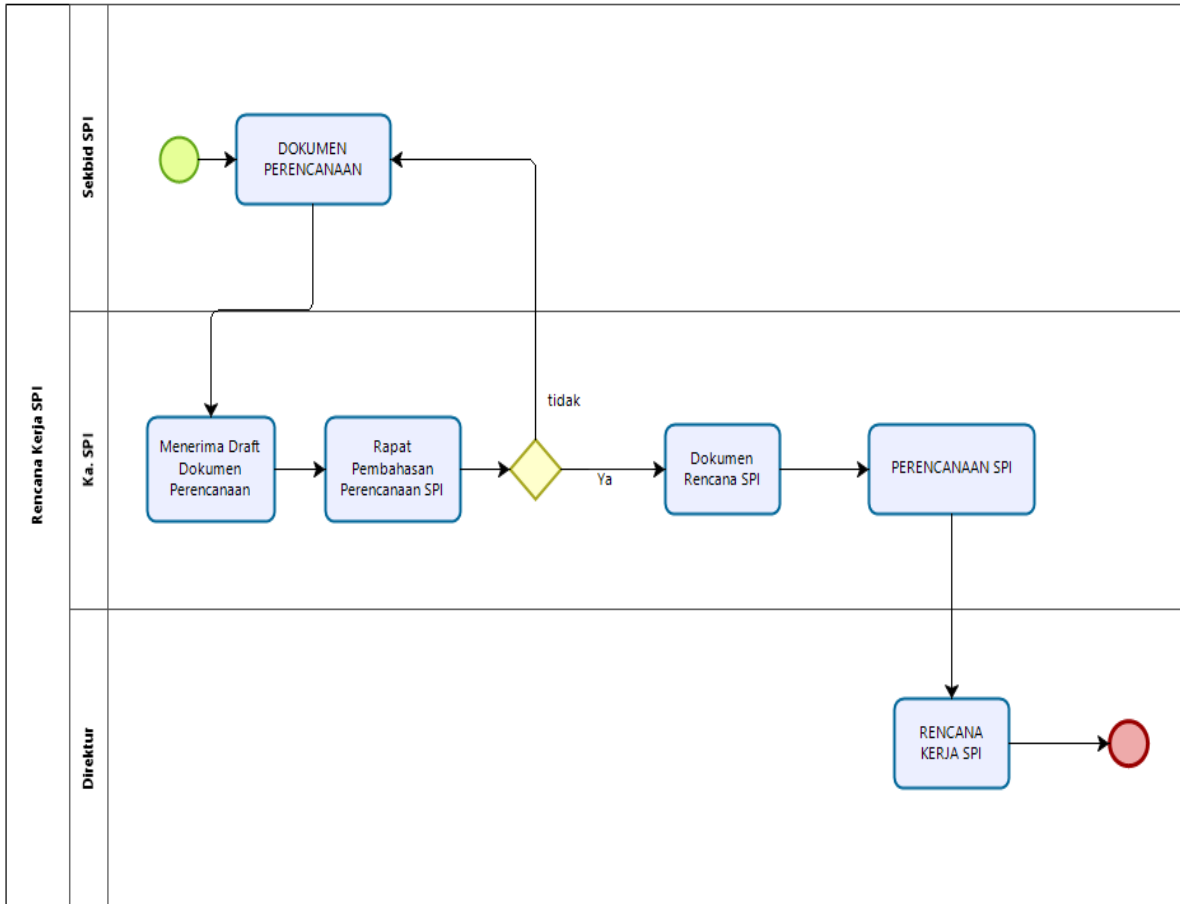

37. AUDIT MANDATORY

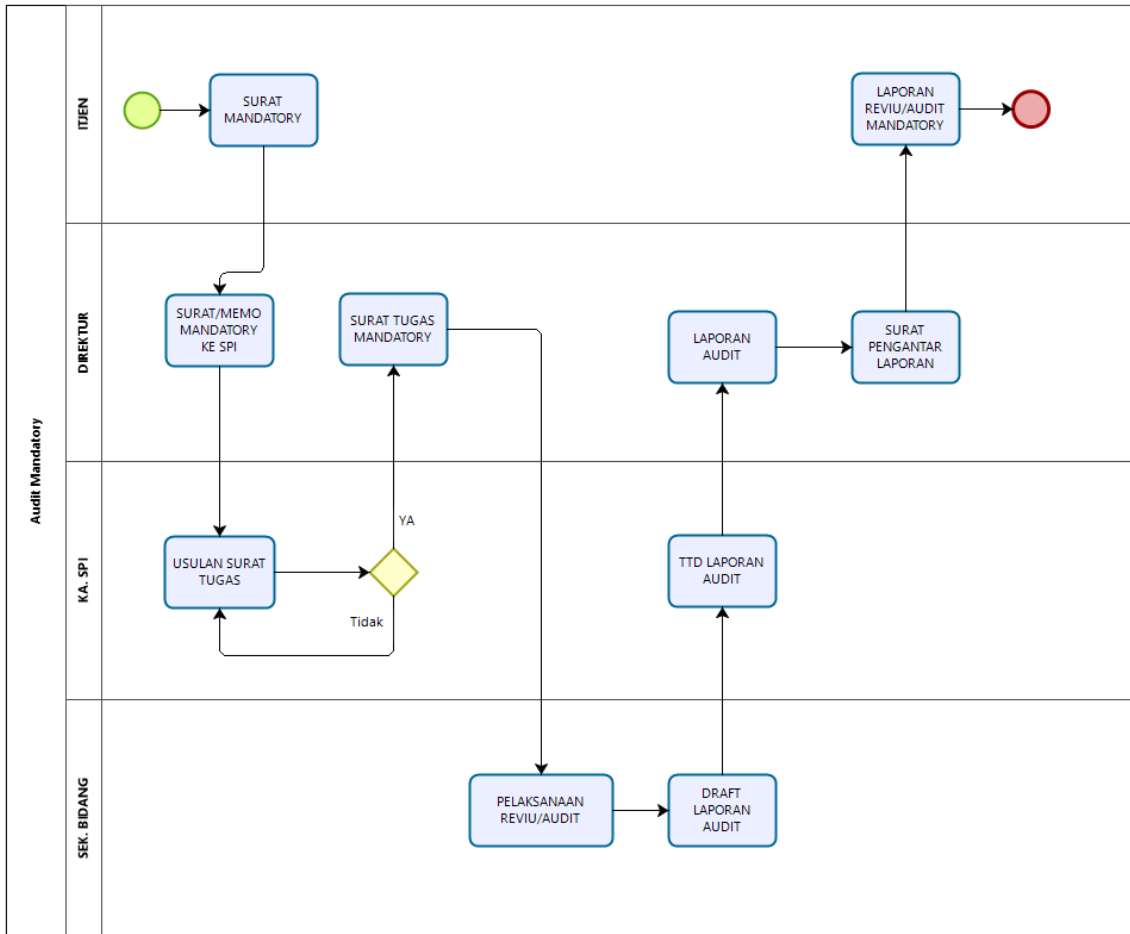

38. AUDIT INSIDENTAL

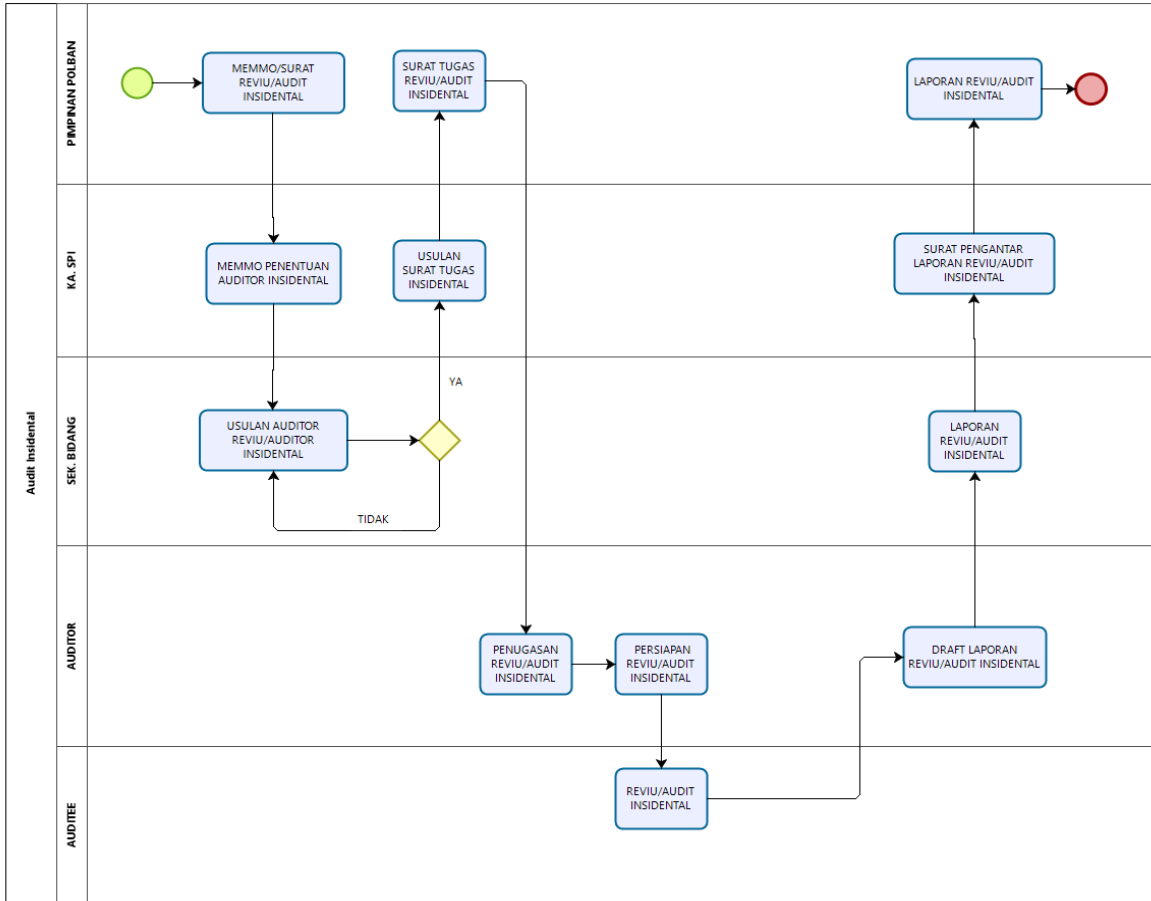

39. LAPORAN REVIU - TUGAS BIDANG SPI

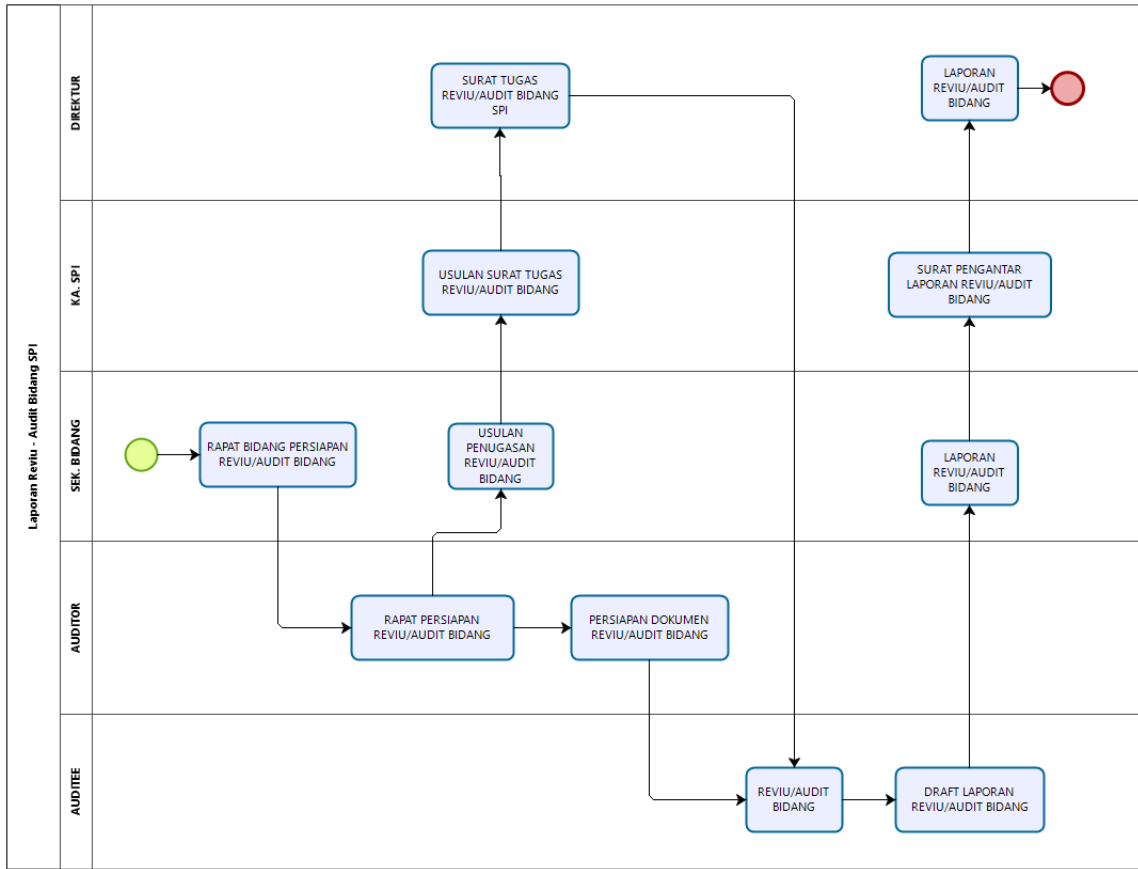

Powered by bizagi Modeler



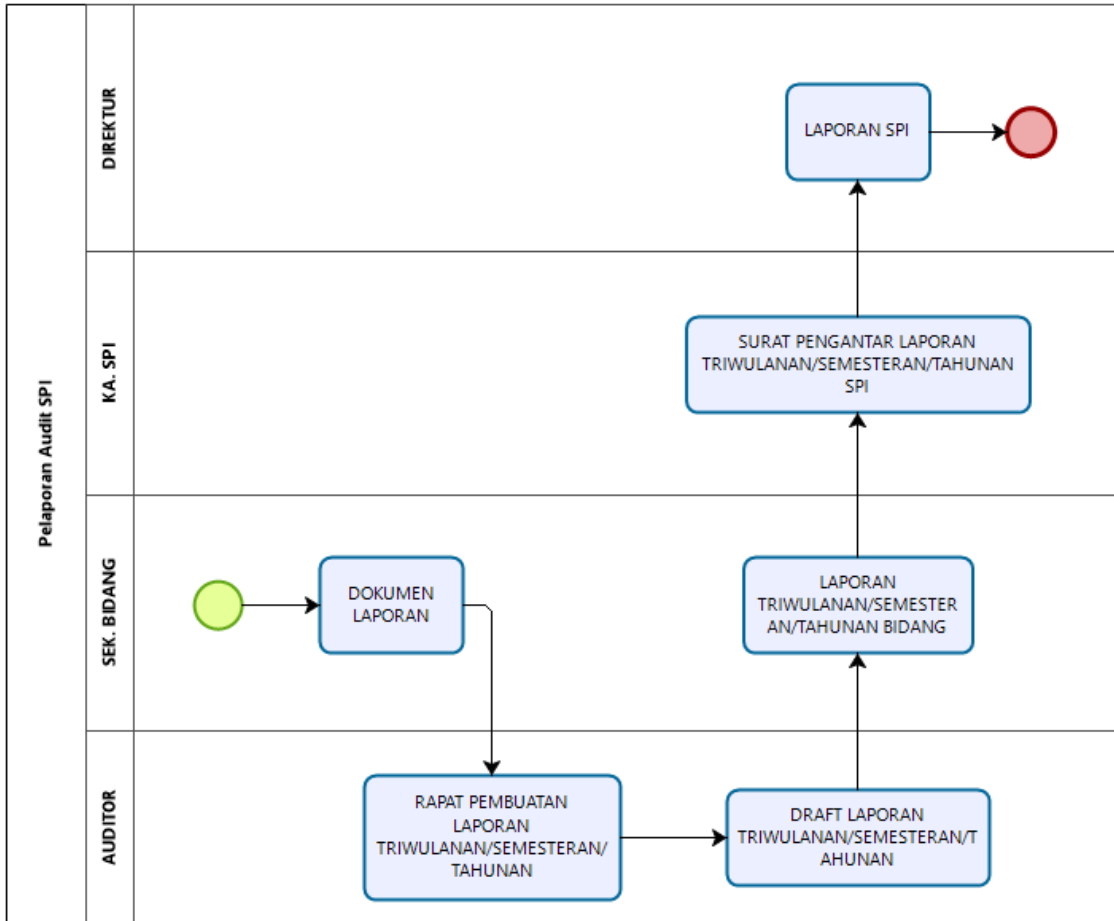









































40. PELAPORAN AUDIT SPI



41. PELAYANAN ADMINISTRASI



42. LAYANAN ADM AKADEMIK

Layanan Adm. Akademik Pusat					
	Kalender Akademik	Pelantikan Mahasiswa Baru	Registrasi Mahasiswa Lama	Registrasi Mahasiswa Baru	Penerbitan SKPI
					
	Administrasi Wisuda	Cuti Akademik	Pemberhentian Mahasiswa	Pengelolaan PDDIKTI	Legalisasi Dokumen Akademik
Layanan Adm. Akademik Jurusan					
	Mencetak Daftar Nilai/Transkrip	Aktif Kembali dari Cuti Akademik	Penerbitan SK CA	Menyiapkan Dokumen SKPI	Translate Dokumen Akademik
					
	Evaluasi Kelulusan/Yudisium	Penerbitan Surat Keterangan Pengganti Ijazah	Penerbitan Surat Keterangan	Penerbitan Dokumen Akademik	
					
	Pembuatan Jadwal Ujian	Persiapan Ujian	Pelaksanaan Ujian	Entry Nilai BBPM (On Line)	Entry Nilai BBPM (Manual)
					
	Ketidakhadiran Mahasiswa	Menyiapkan KRS	Cetak Absensi Mahasiswa	Penerbitan Surat Peringatan	Rekomendasi CA
					
	Kunjungan Industri	Pembuatan Surat Pengantar	Identifikasi dan Jadwal Kuliah	Pelaporan PDPT Polban	Penilaian Karya Ilmiah Dosen
					
Mengumpulkan Data Akademik	Rekapitulasi & Olah Data	Peminjaman Sarana Belajar	Layanan Tugas Akhir	Peminjaman Alat di Laboratorium	
					
Perbaikan Alat Laboratorium	Praktikum di Laboratorium	Rekap Kehadiran Dosen	Rekap Mengajar Dosen PartTime	Capaian Hasil Belajar Mahasiswa	
					
Peminjaman Bahan di Laboratorium					

43. KALENDER AKADEMIK

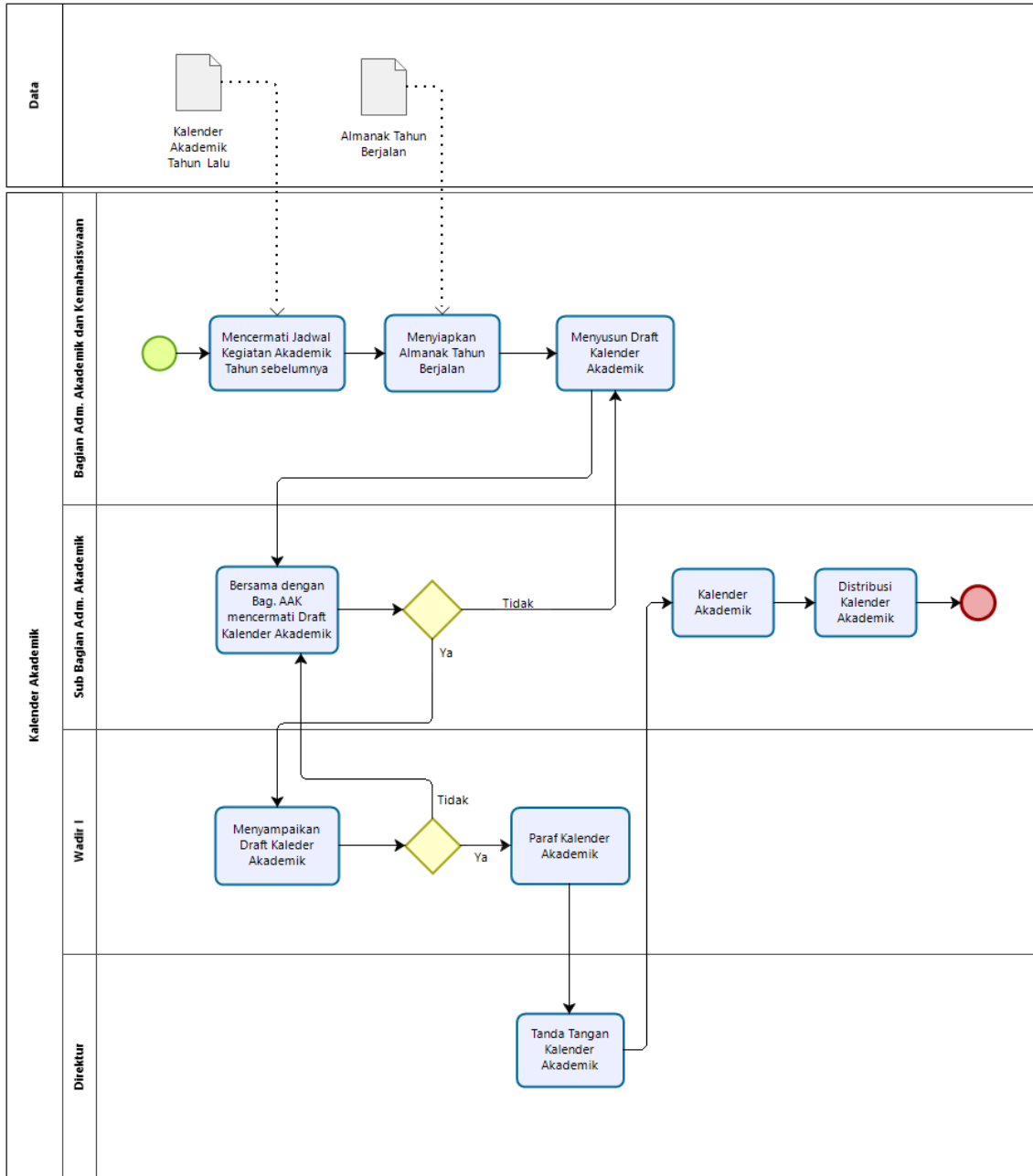

44. MENYIAPKAN KARTU RENCANA STUDI (KRS)

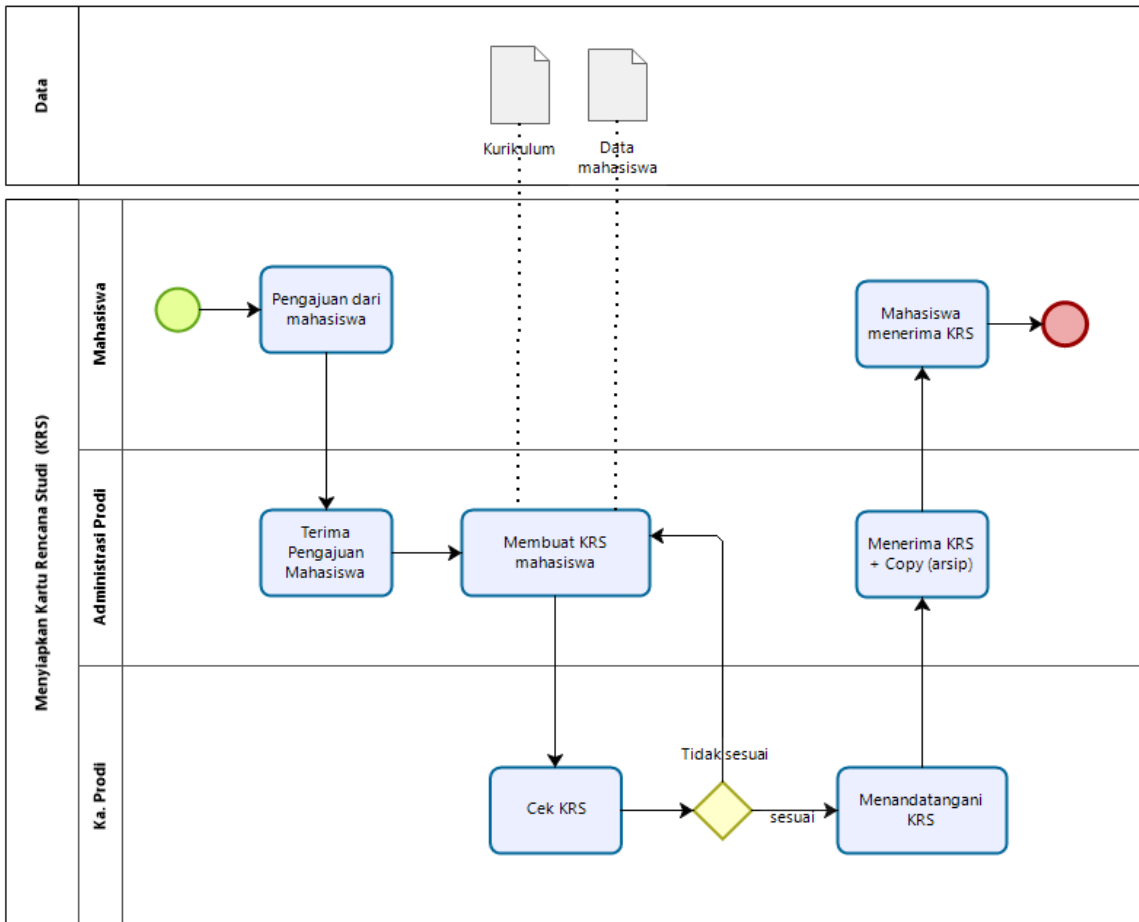

45. PELANTIKAN MAHASISWA BARU

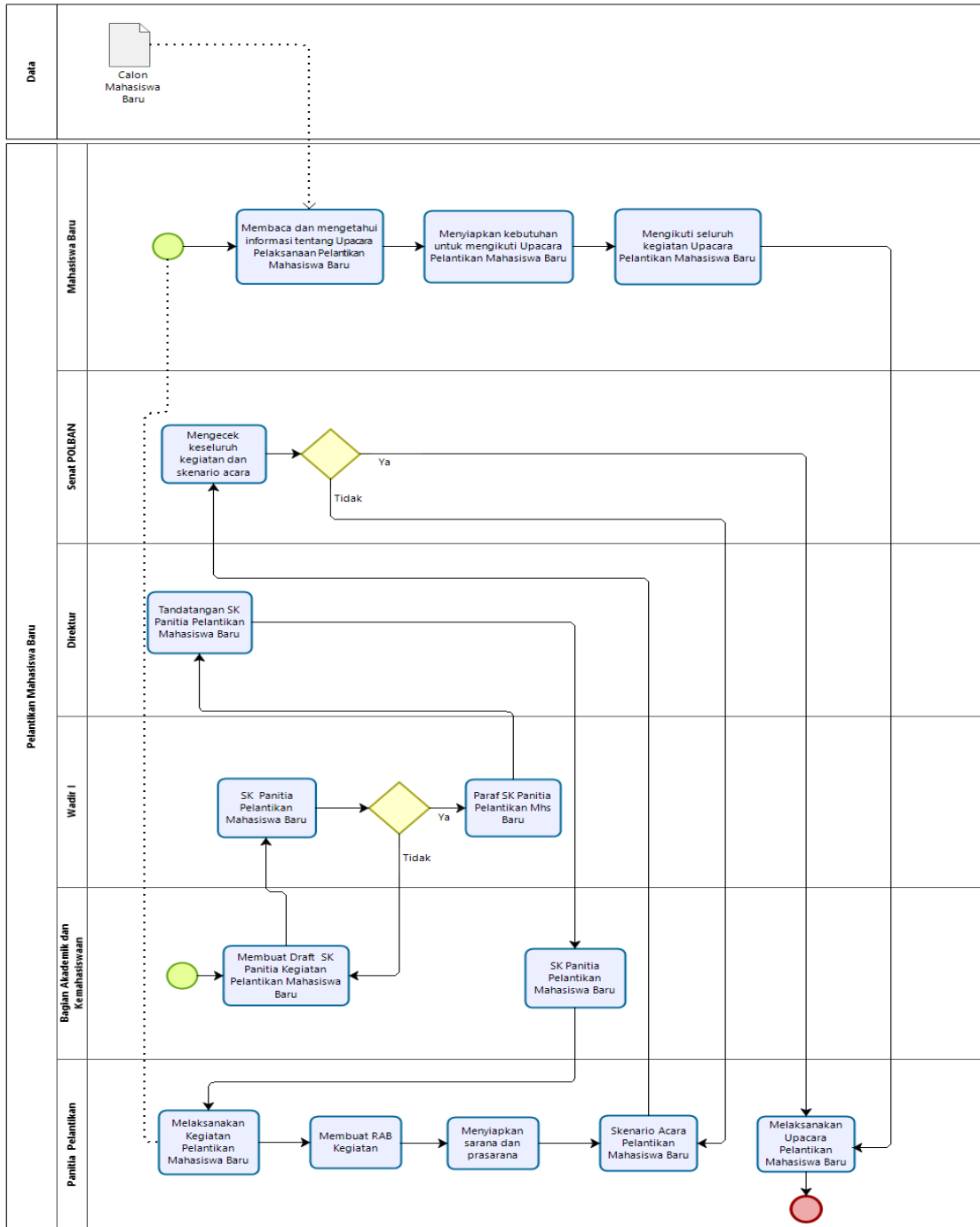

46. REGISTRASI MAHASISWA BARU

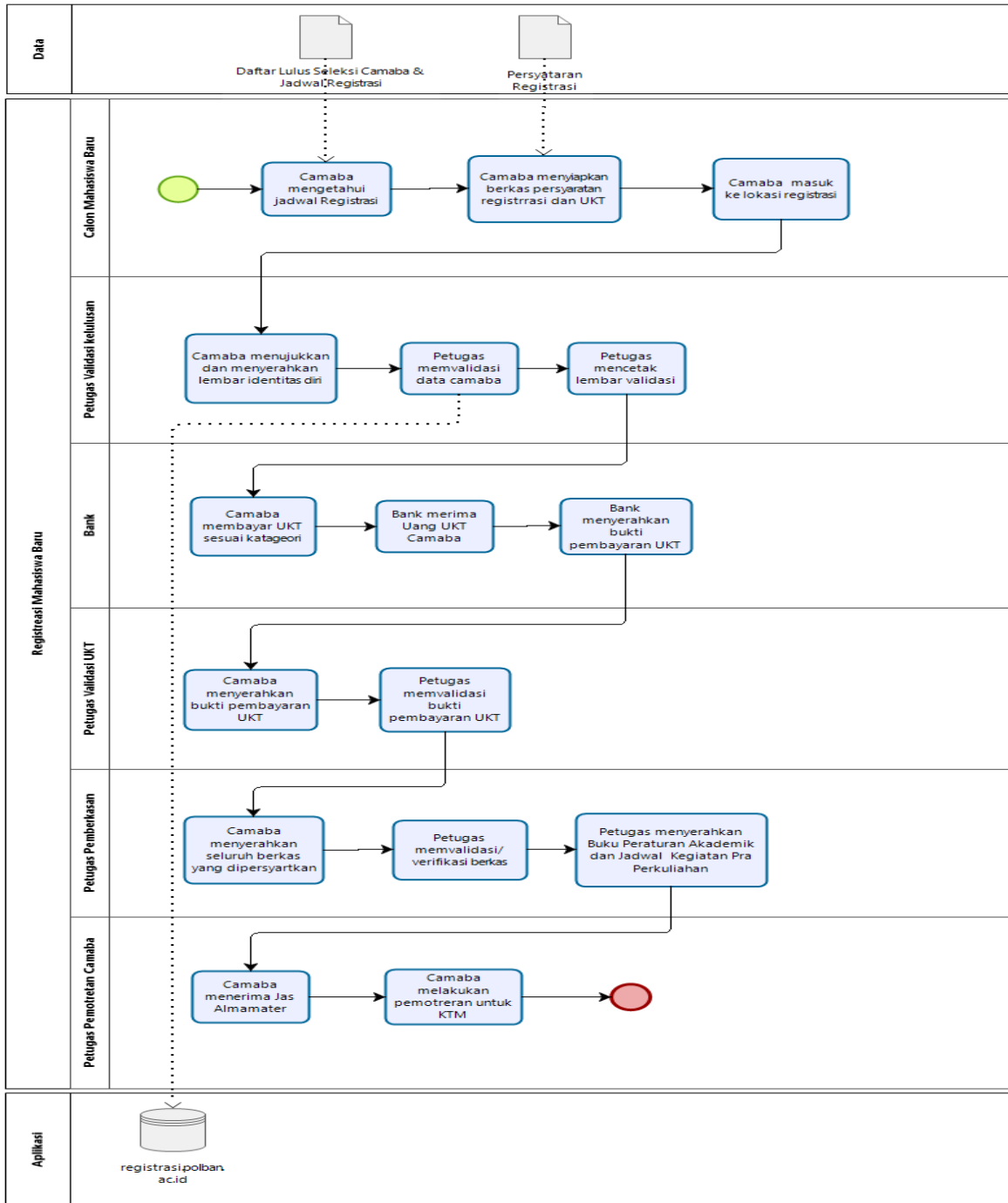

47. REGISTRASI MAHASISWA LAMA

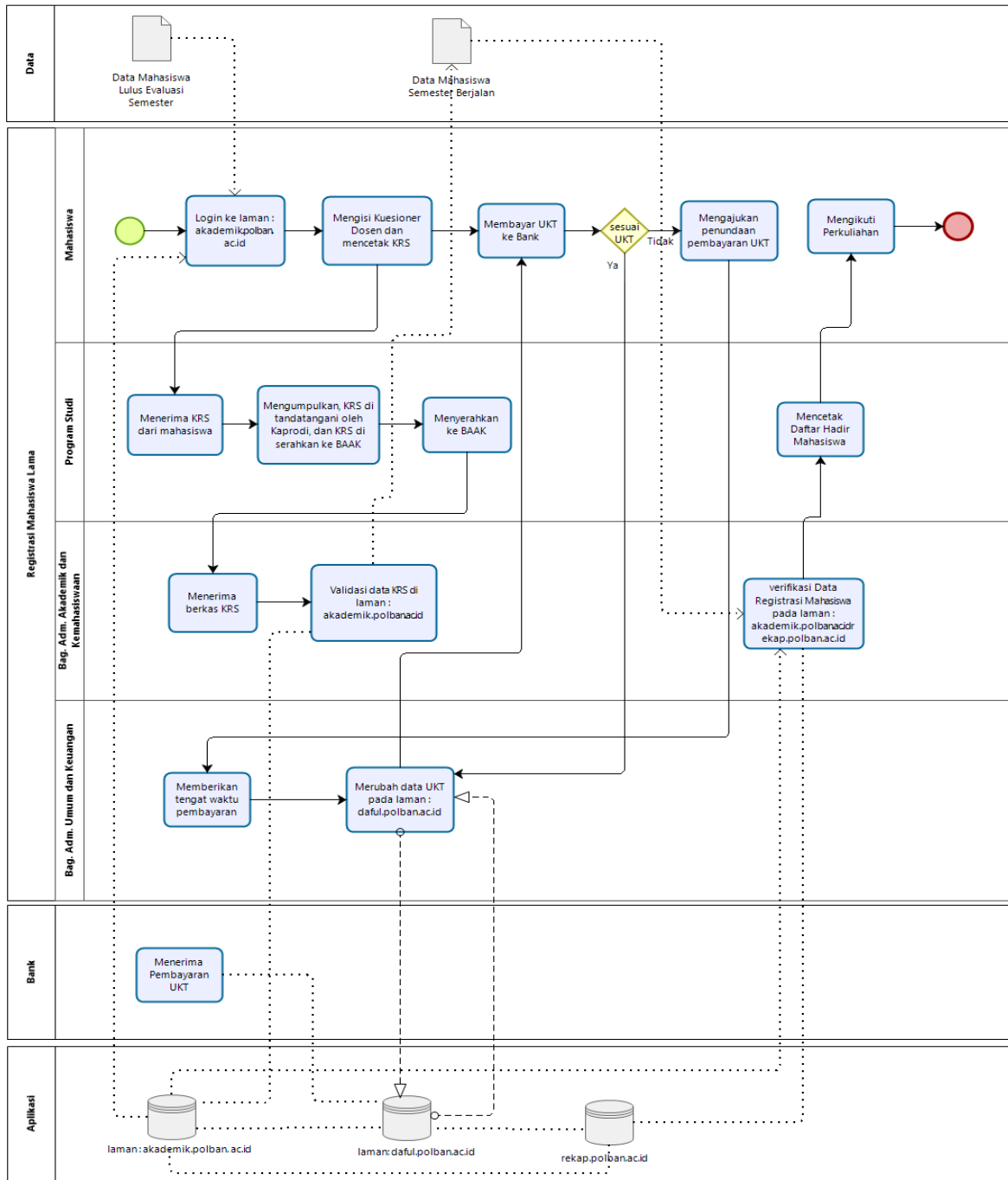

48. IDENTIFIKASI DAN JADWAL KULIAH

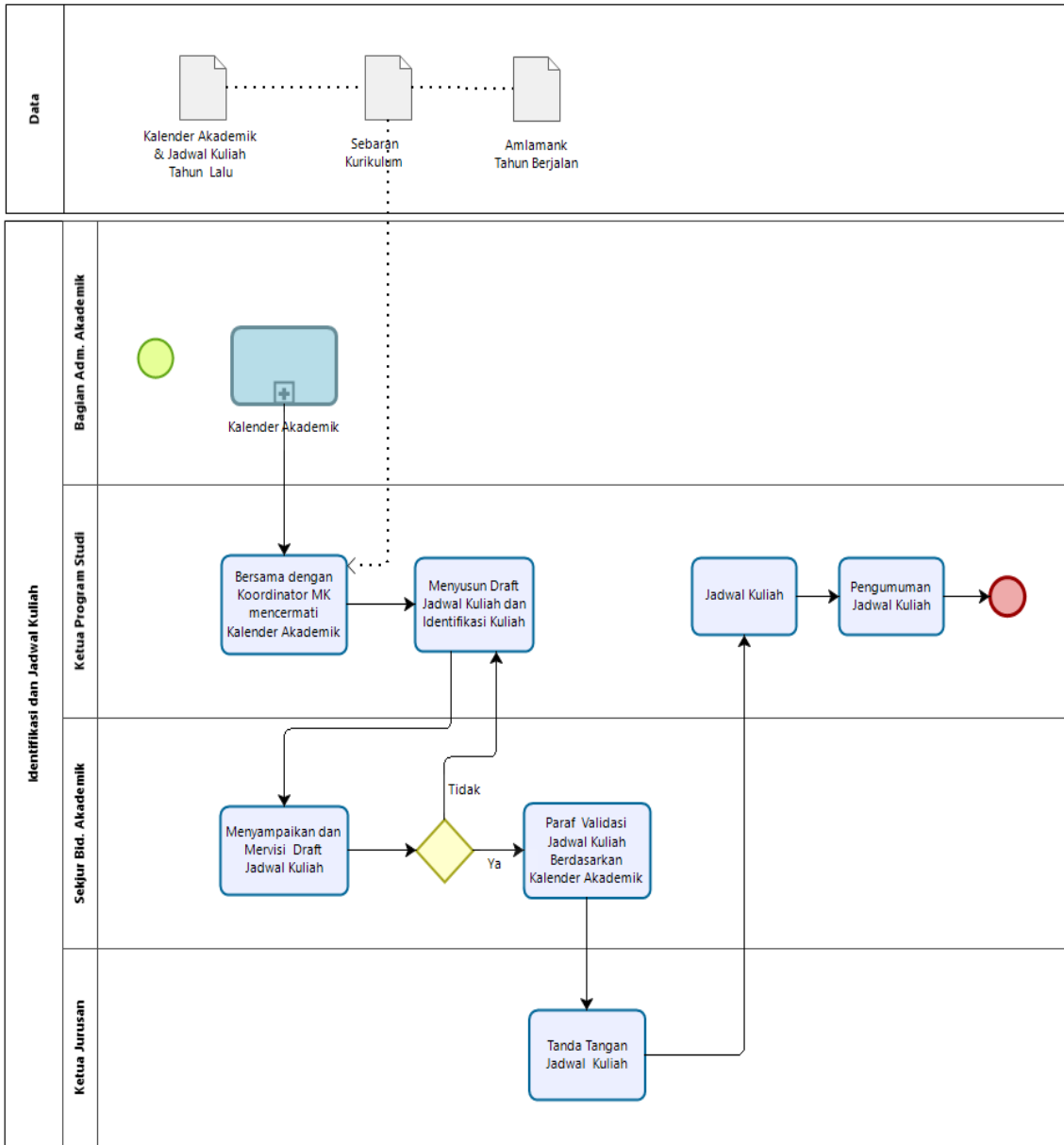

49. PENERBITAN DOKUMEN AKADEMIK

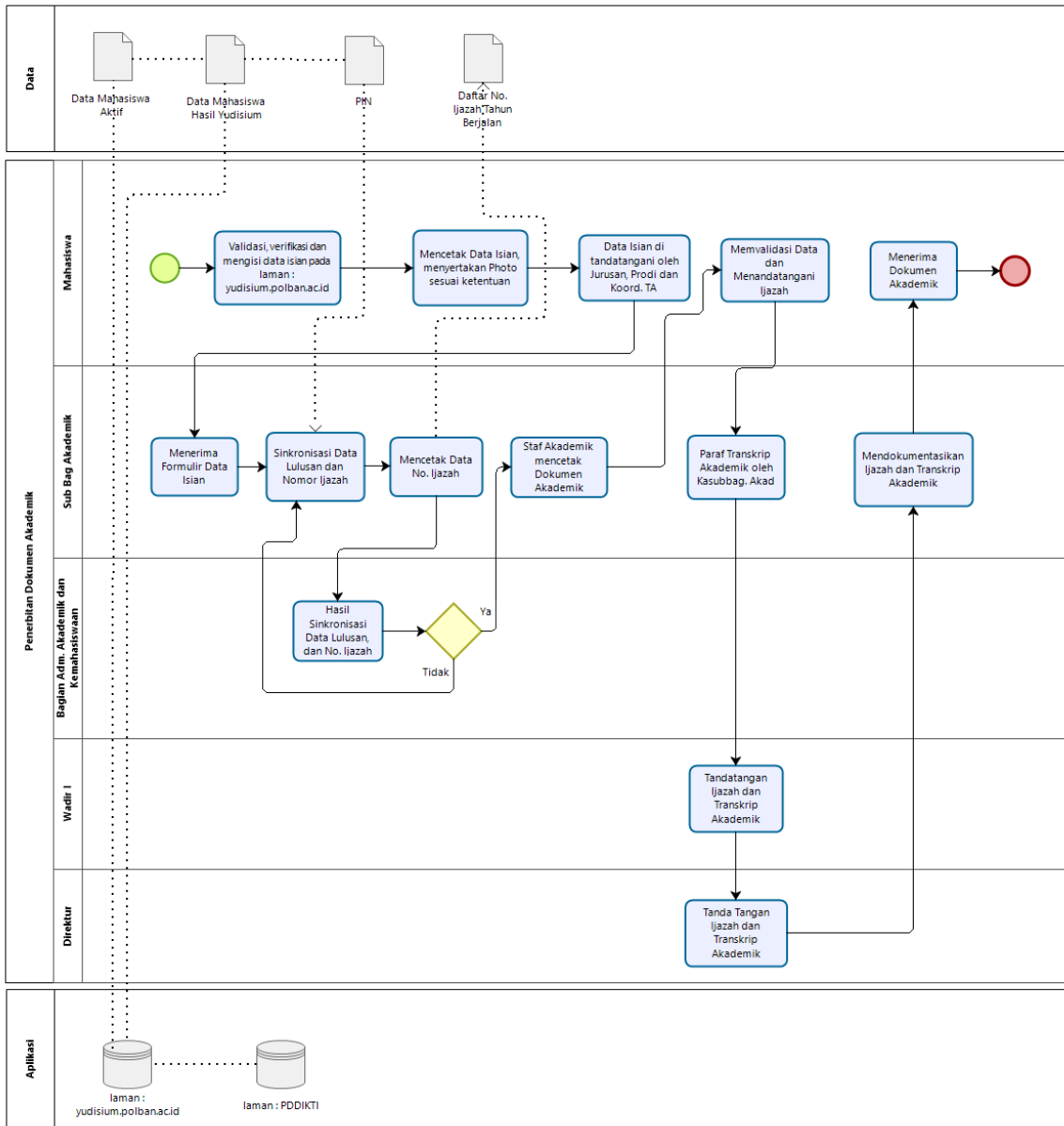

50. PENERBITAN SKPI

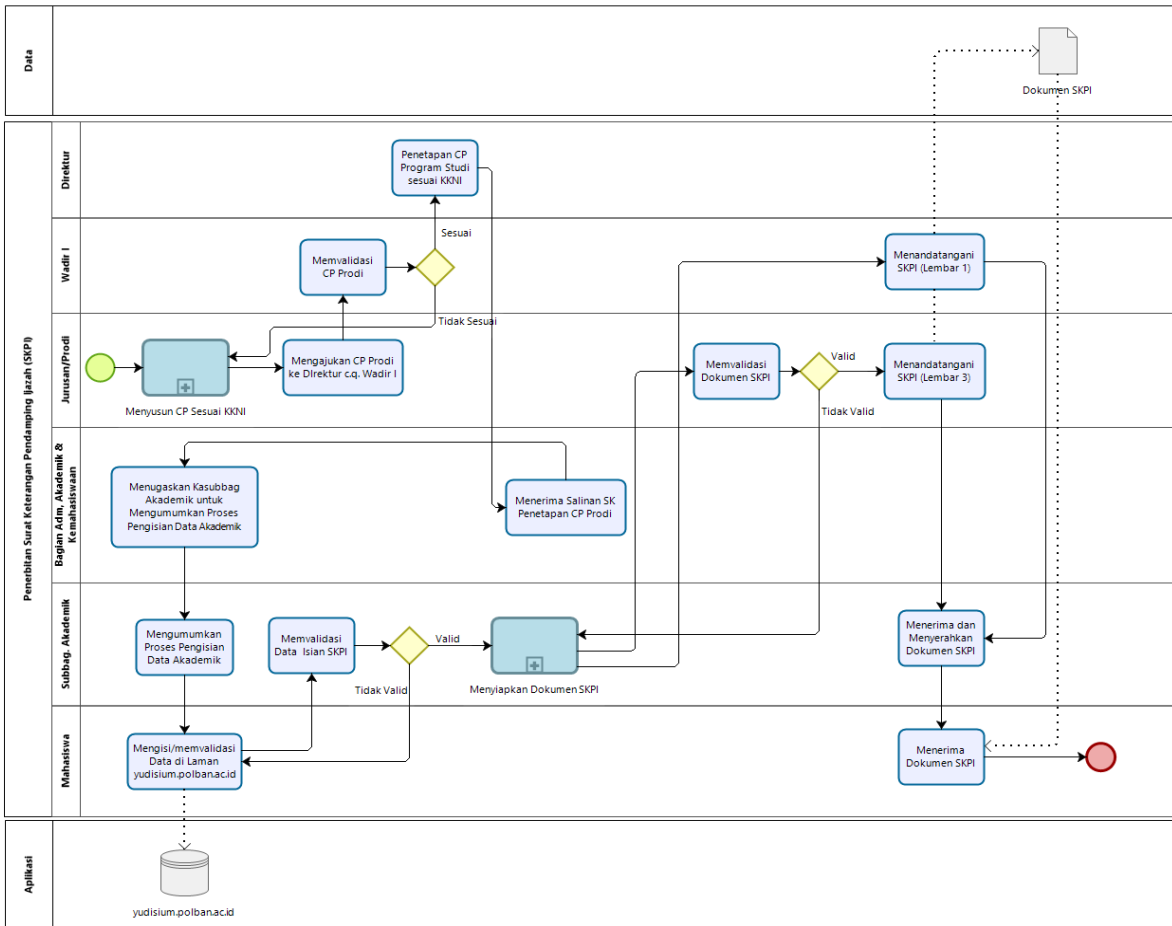

51. REKOMENDASI CA

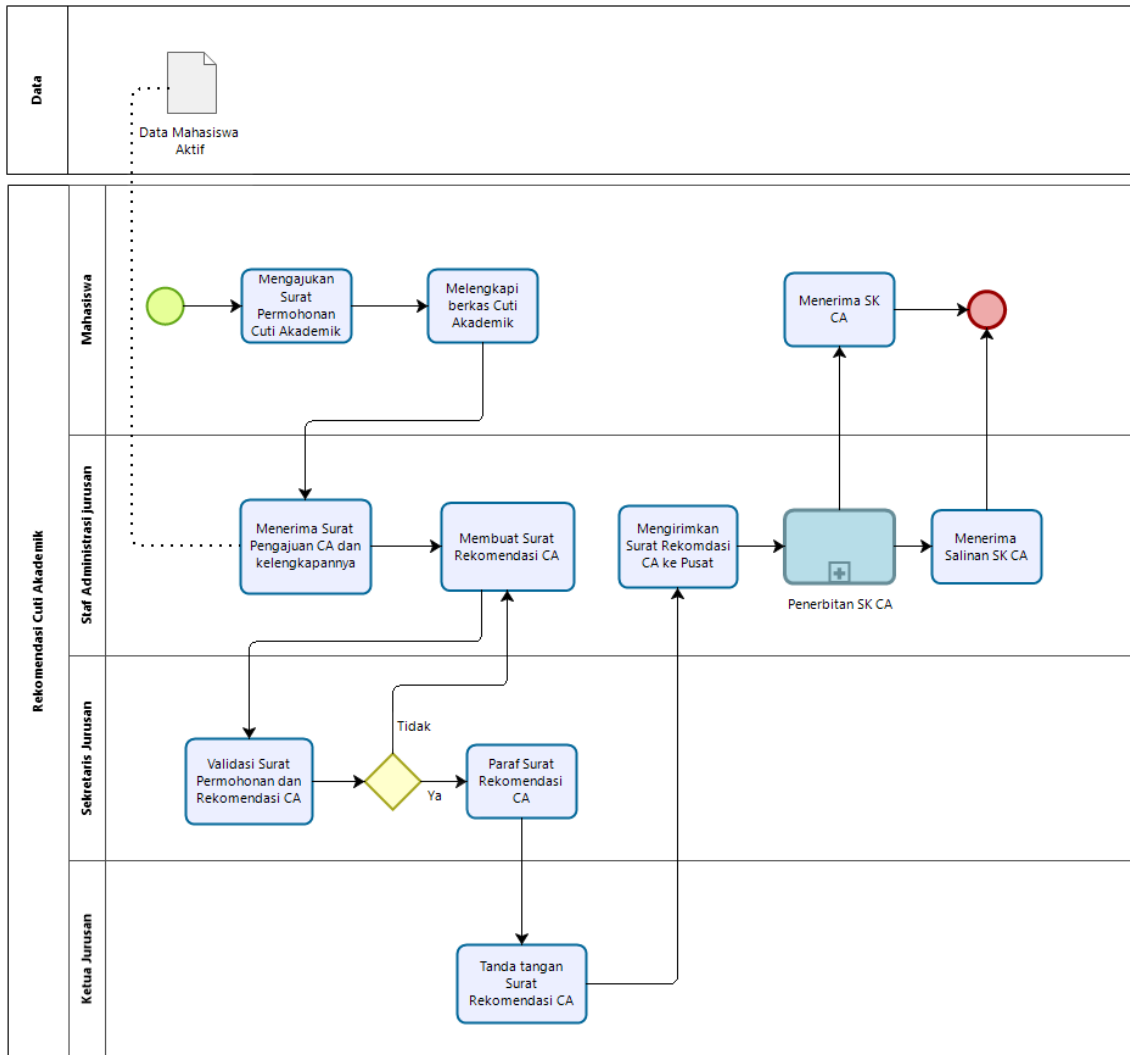

52. PENERBITAN SK CA

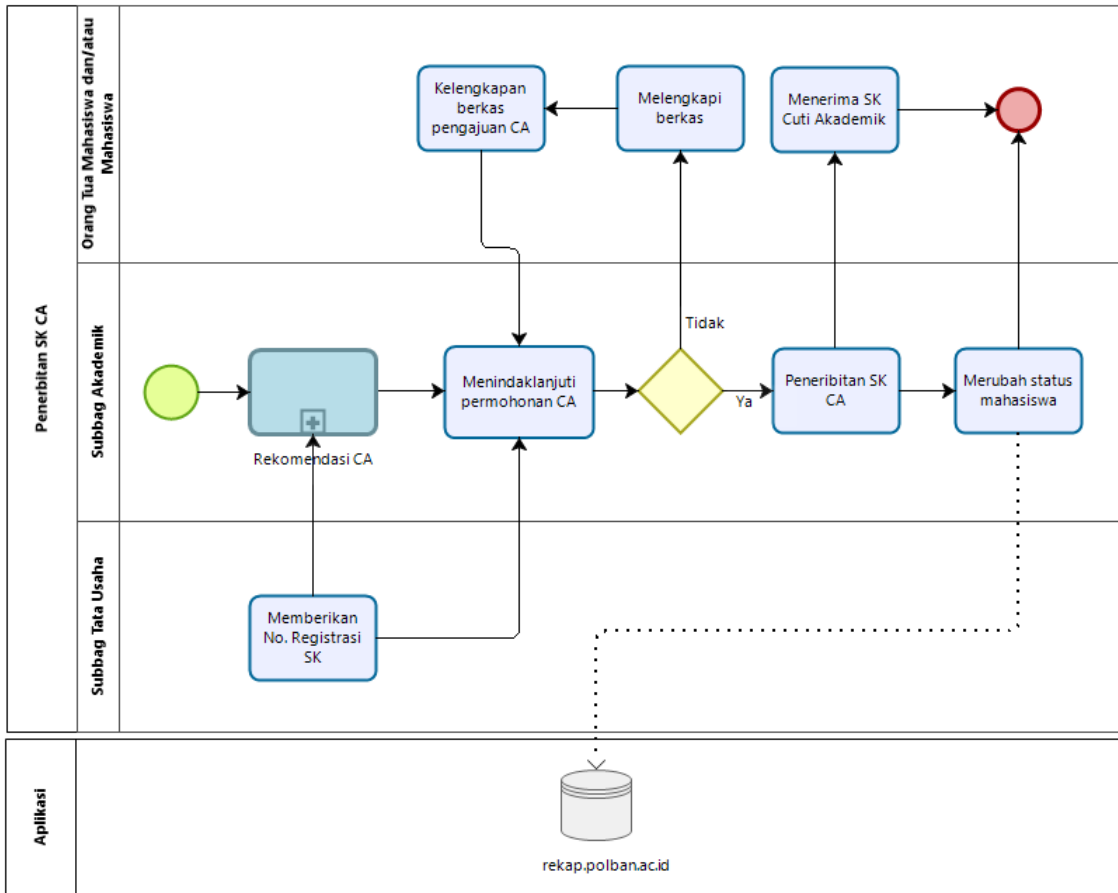

53. CUTI AKADEMIK

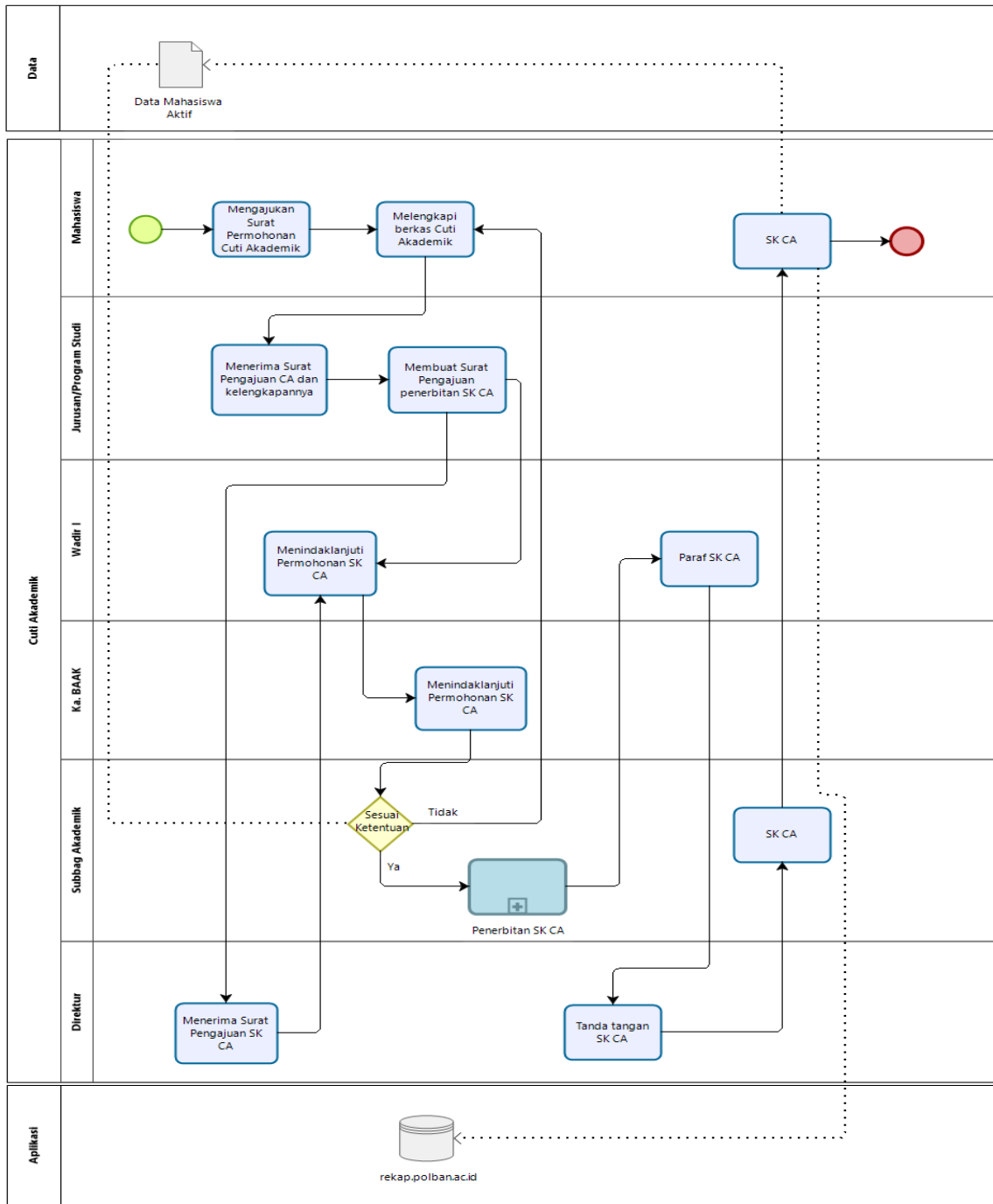

54. AKTIF KEMBALI DARI CUTI AKADEMIK

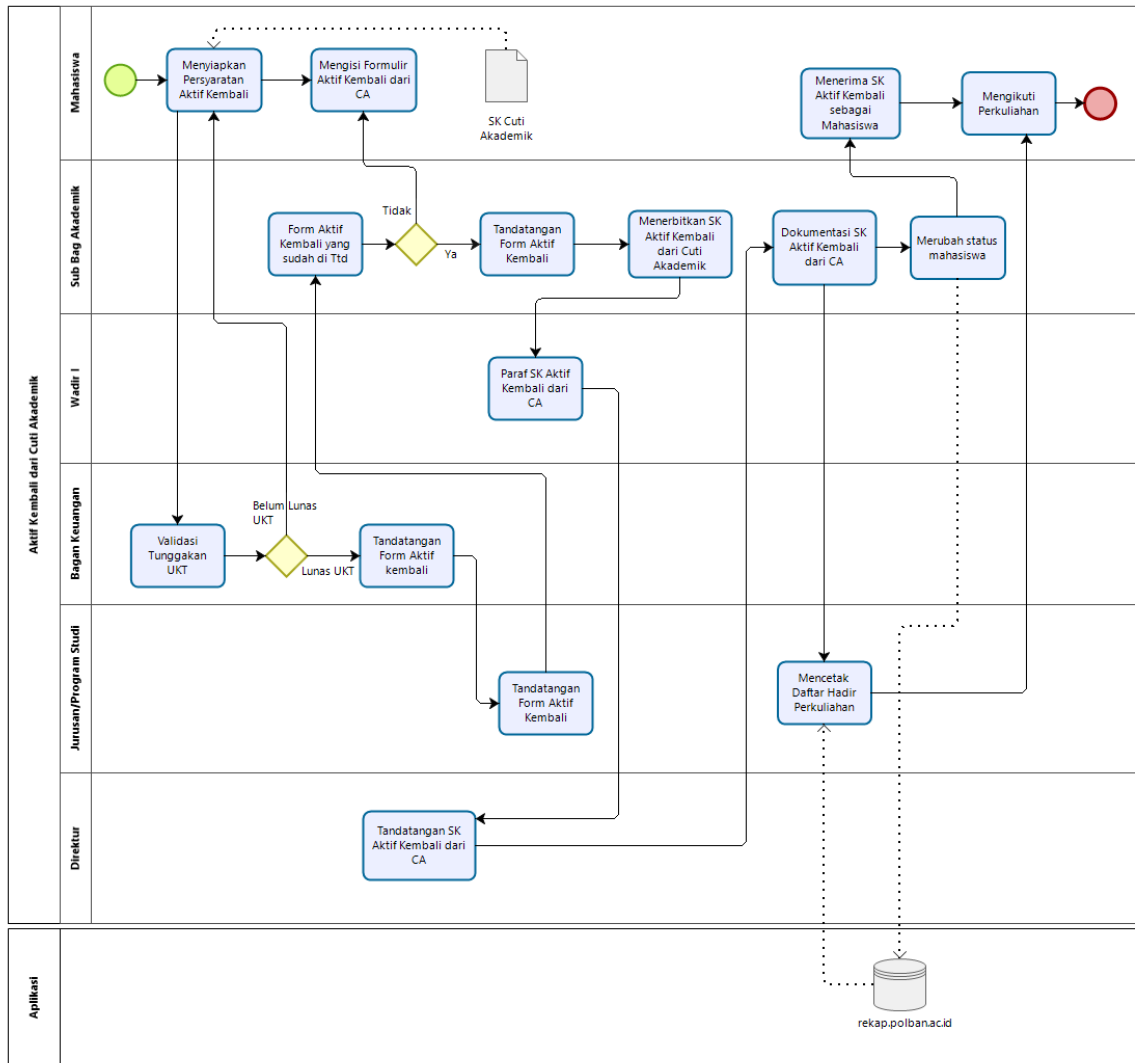

55. PELAKSANAAN UJIAN

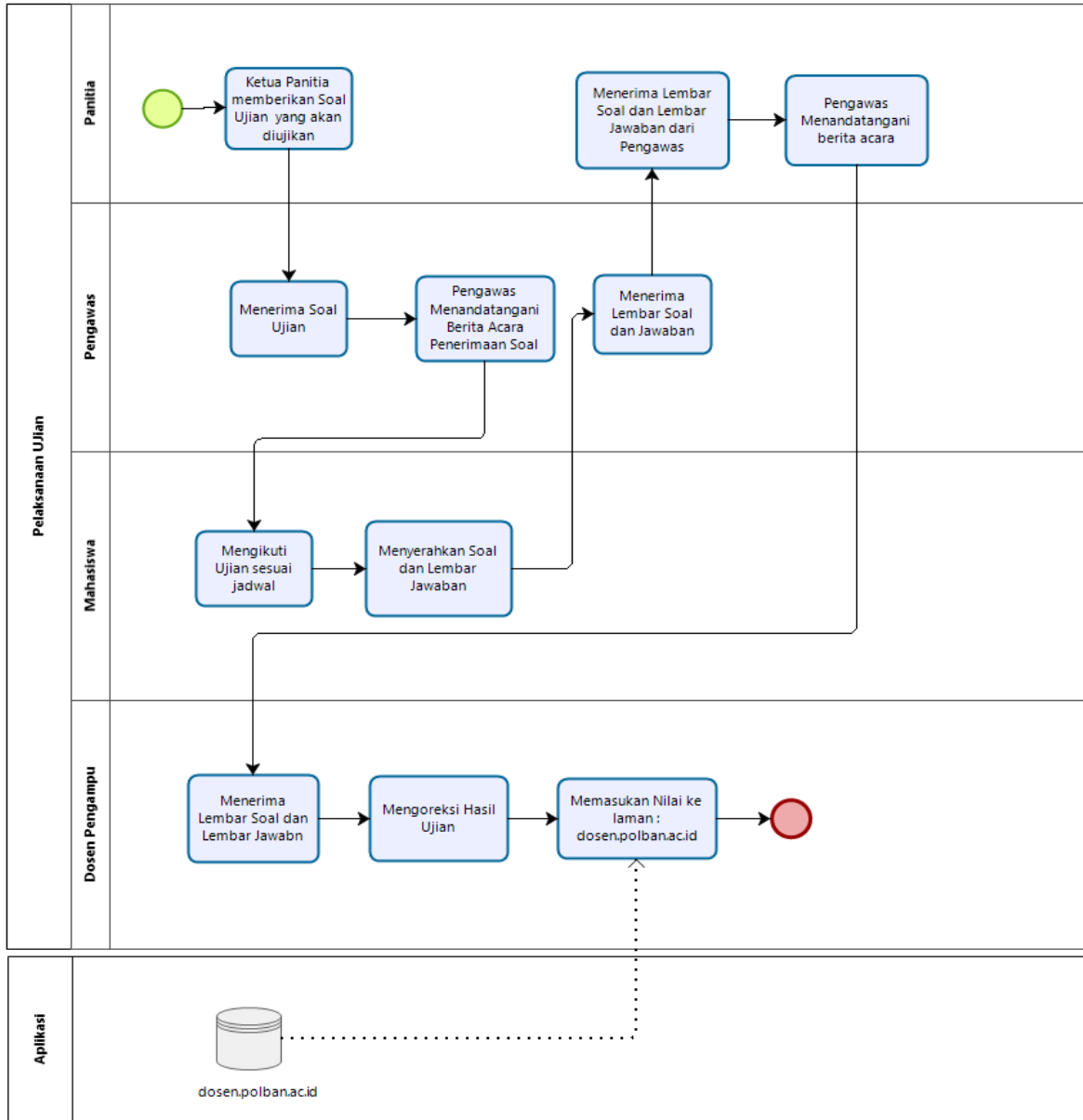

56. PEMBERHENTIAN MAHASISWA

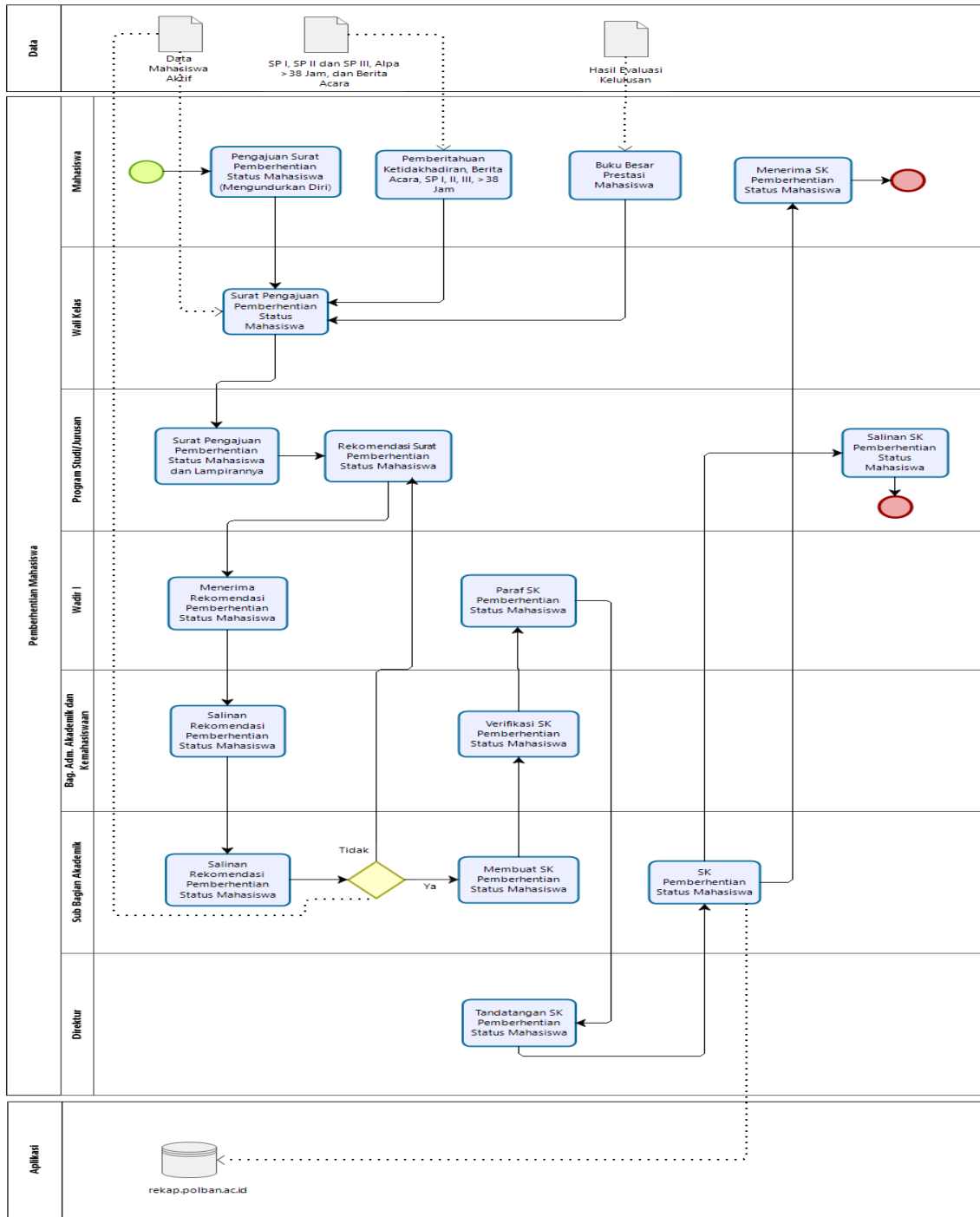

57. PELAPORAN PDPT POLBAN

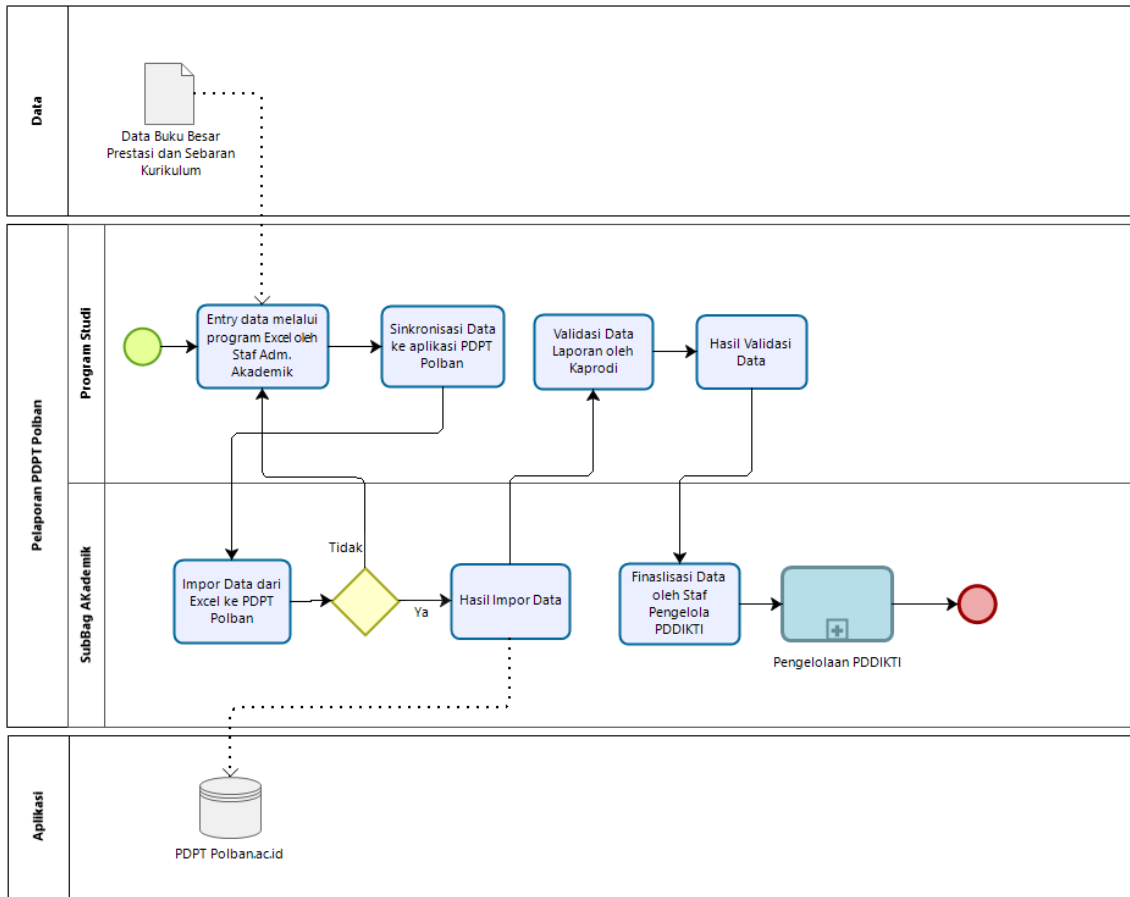

58. ENTRY NILAI BBPM (MANUAL)

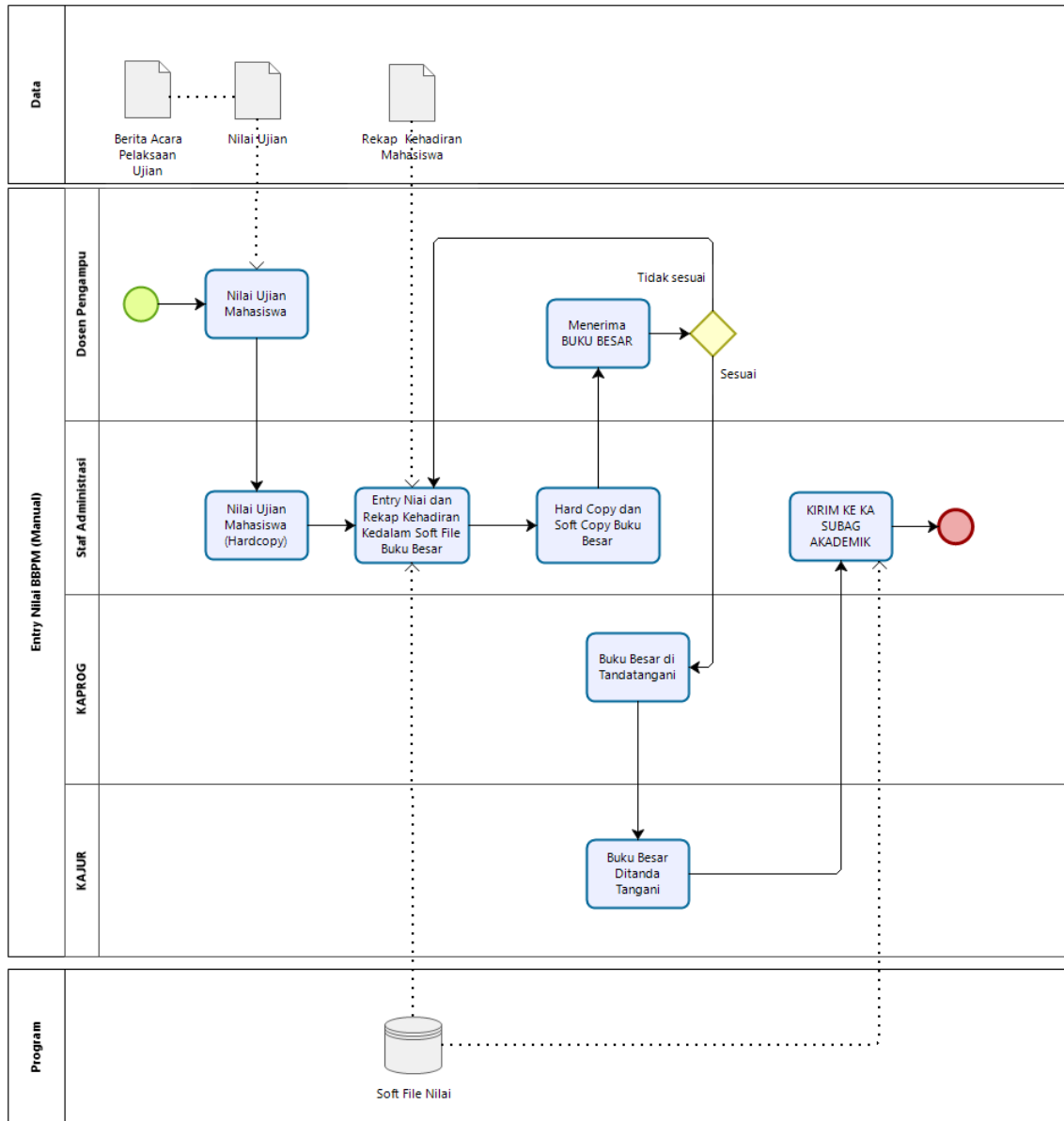

59. ENTRY NILAI BBPM (ON LINE)

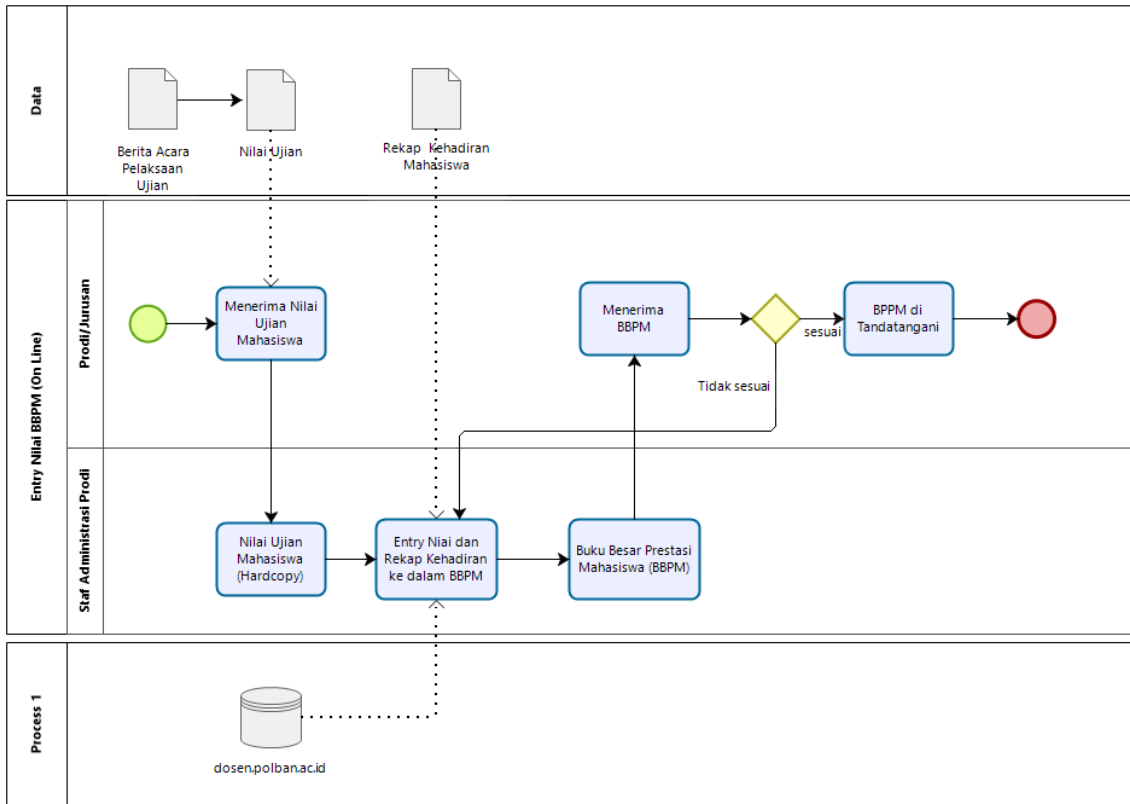

60. KETIDAKHADIRAN MAHASISWA

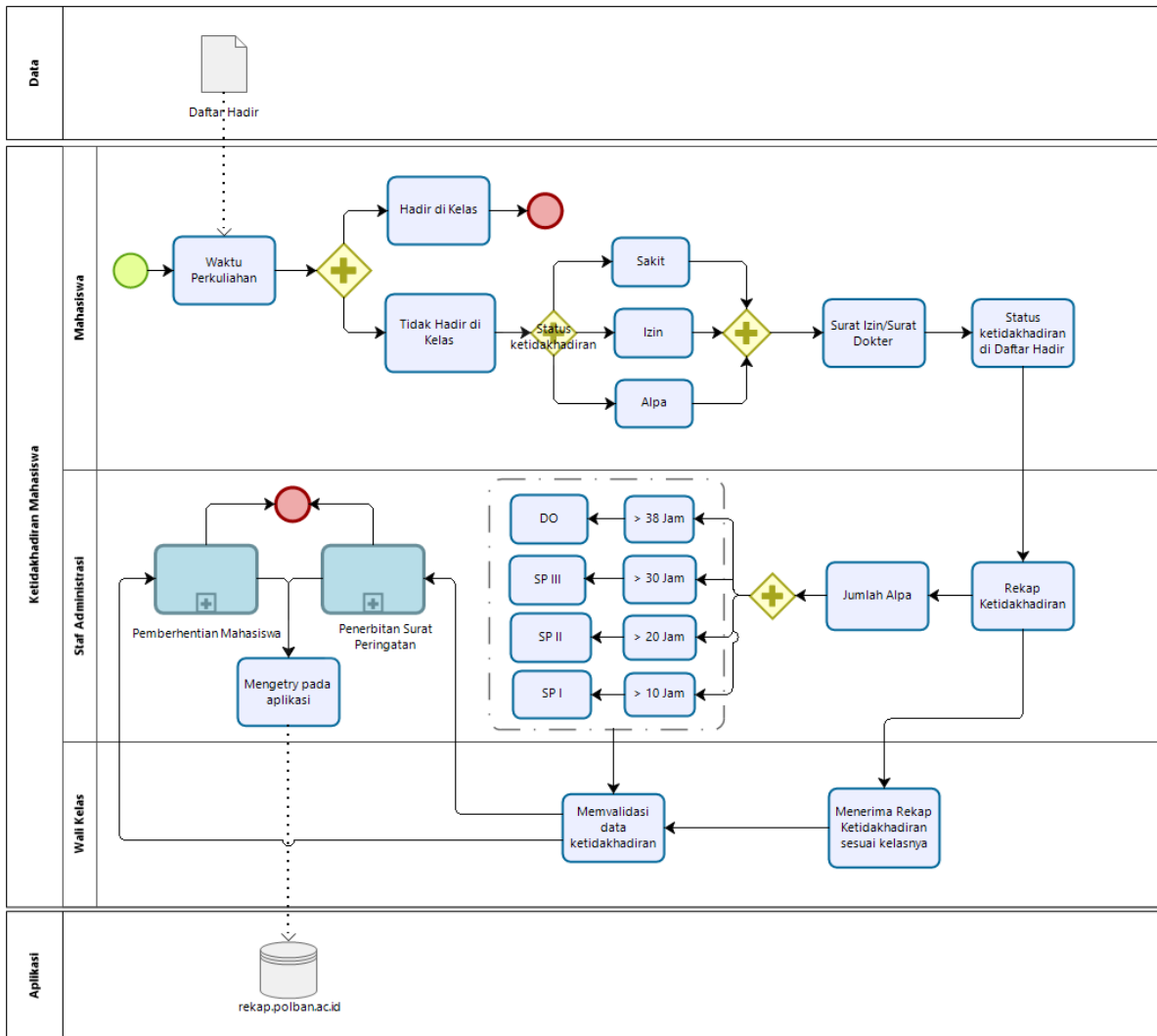

61. PENERBITAN SURAT PERINGATAN

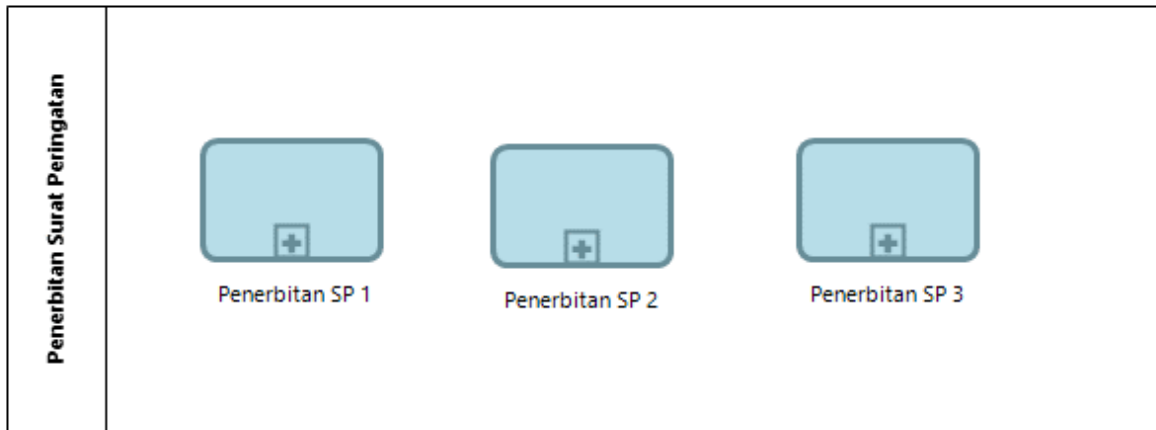

Powered by
bizagi
Modeler

62. PENERBITAN SP 1

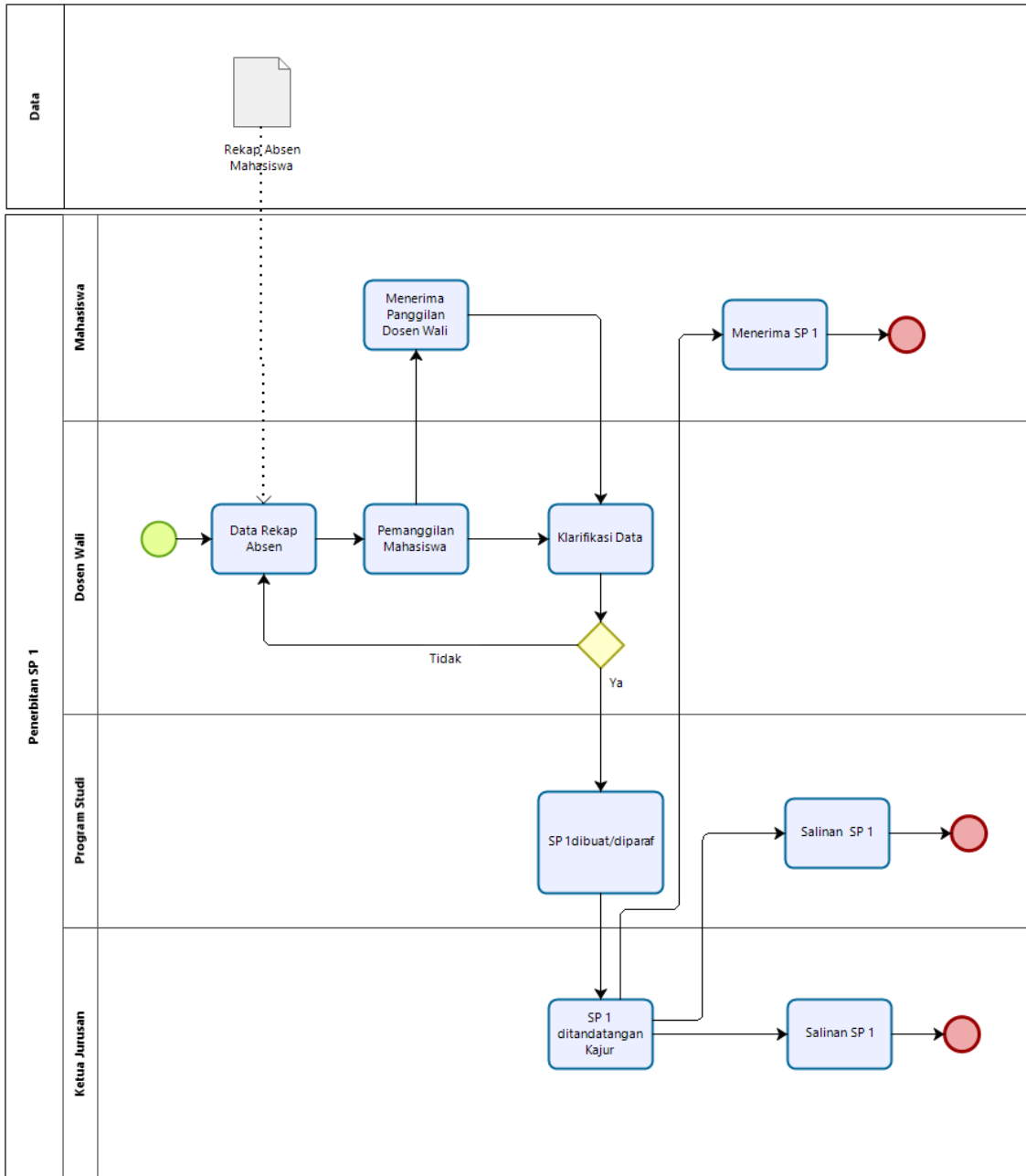

63. PENERBITAN SP 2

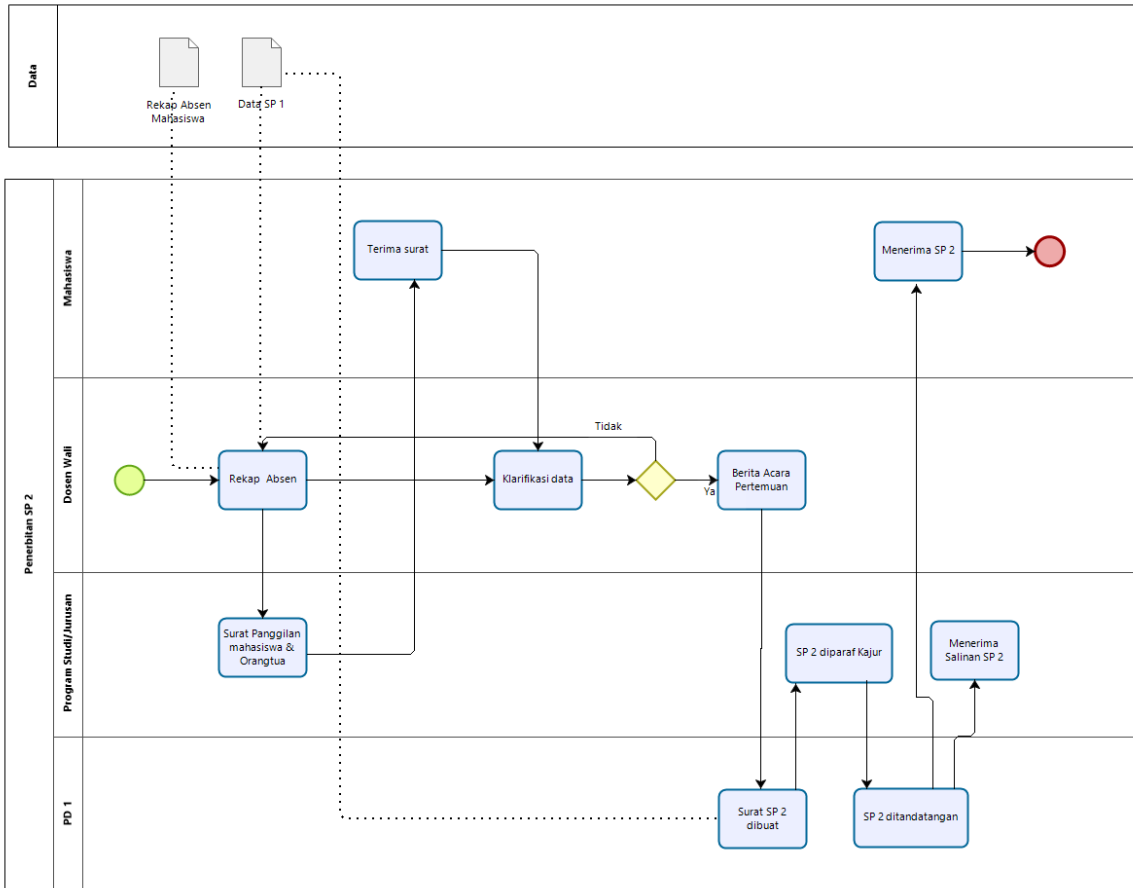

64. PENERBITAN SP 3

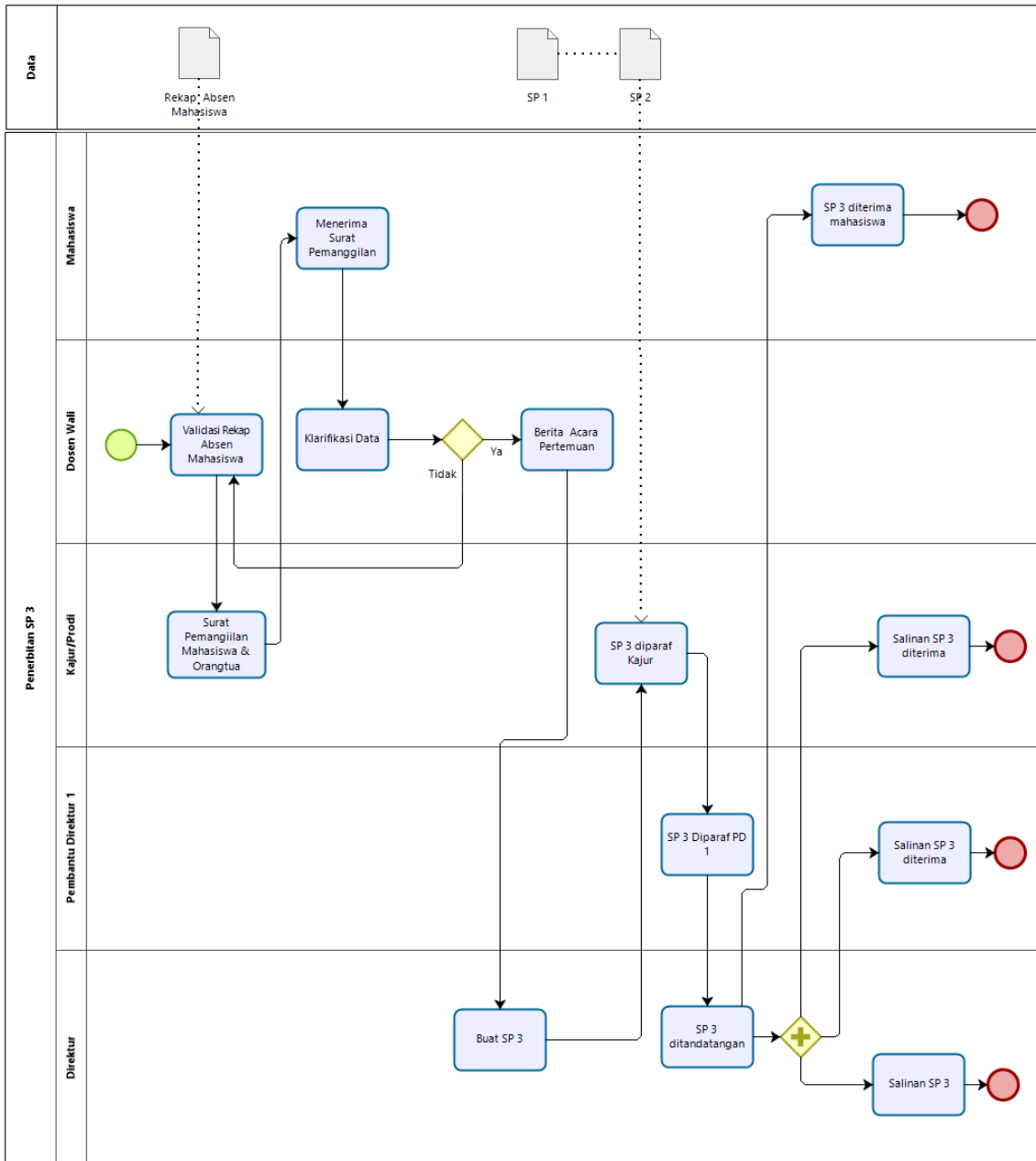

65. KUNJUNGAN INDUSTRI

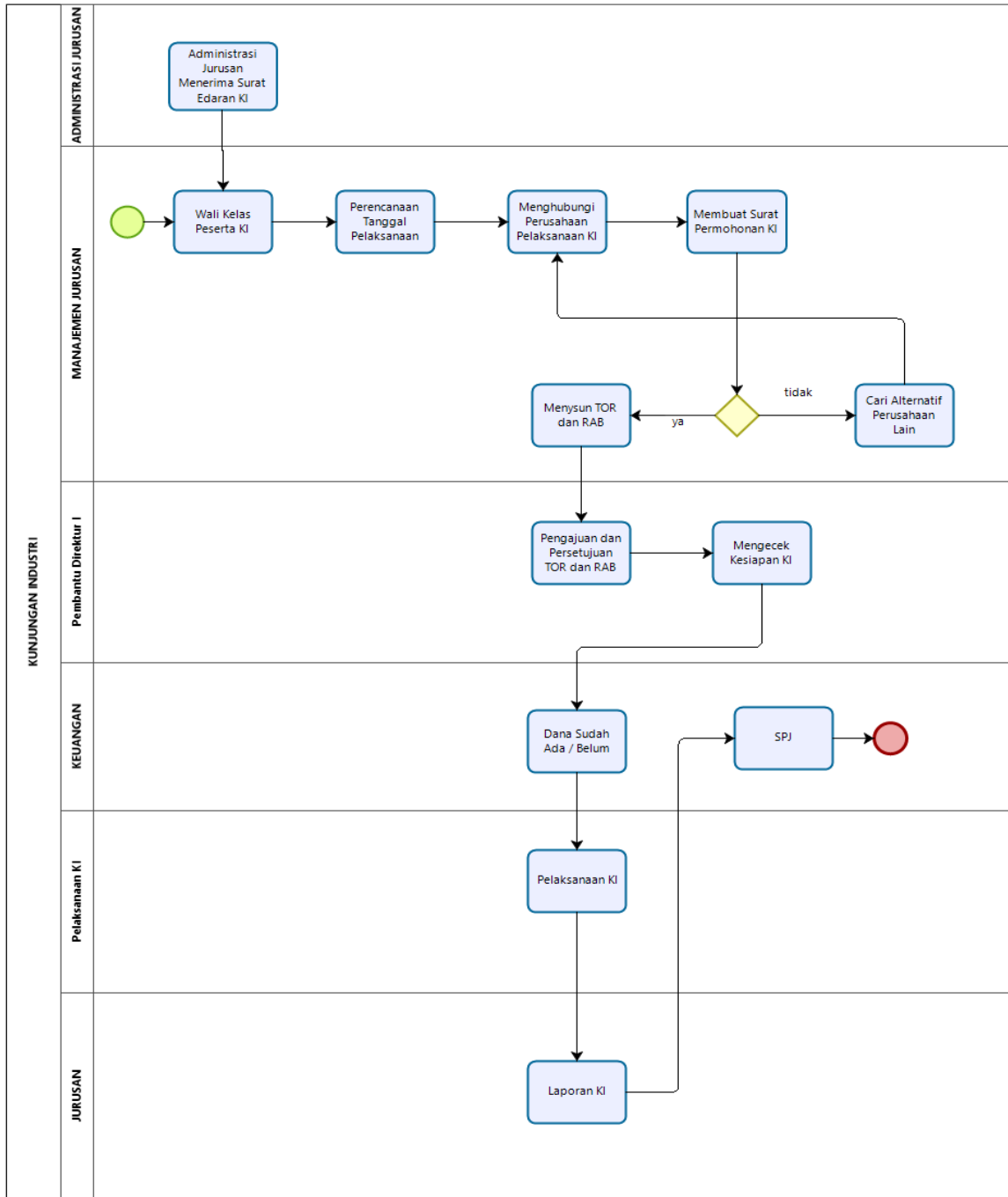

66. PENGEOLAAN KEGIATAN KULIAH DOSEN TAMU

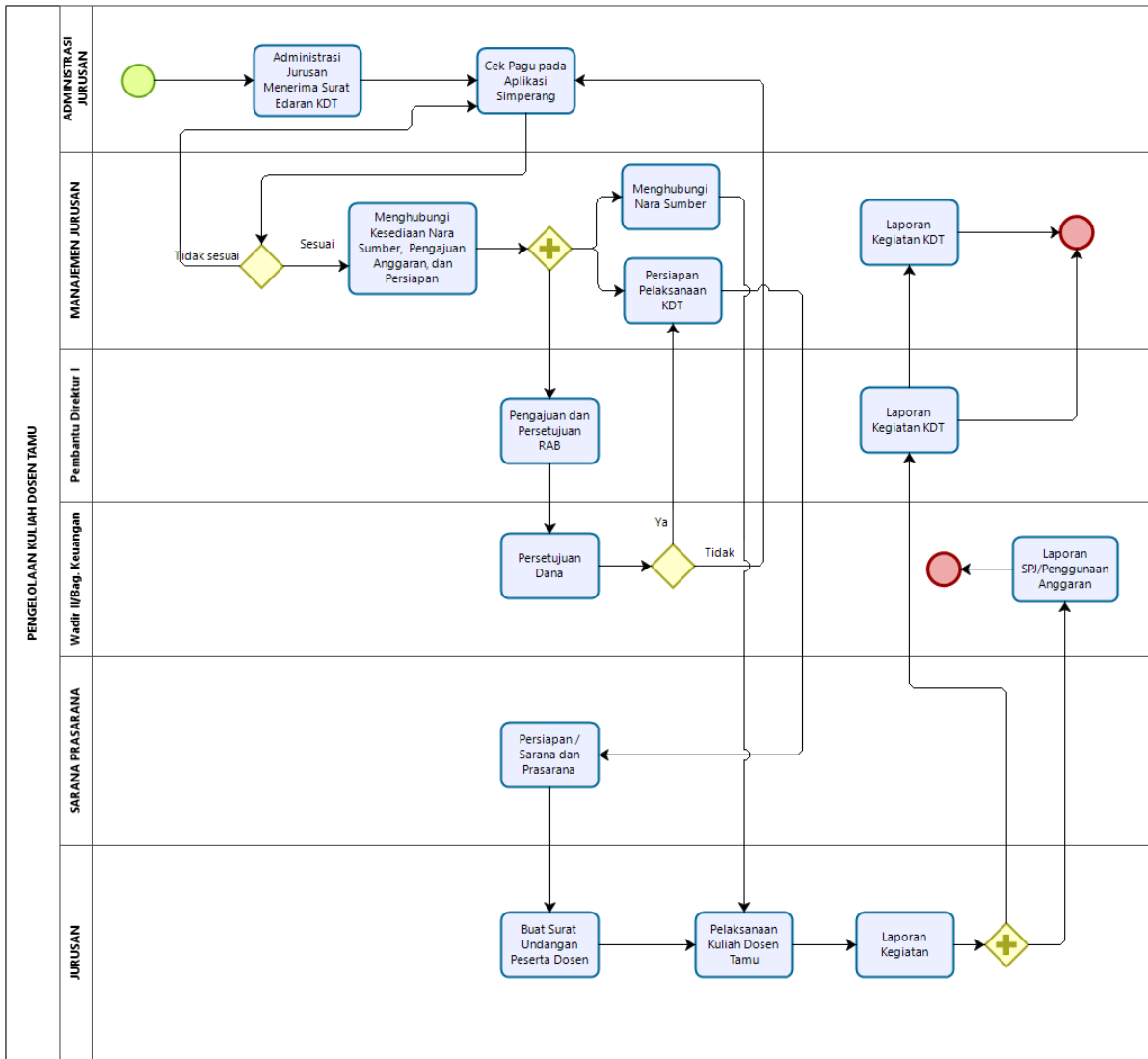

Powered by bizagi Modeler

67. LEGALISASI DOKUMEN AKADEMIK

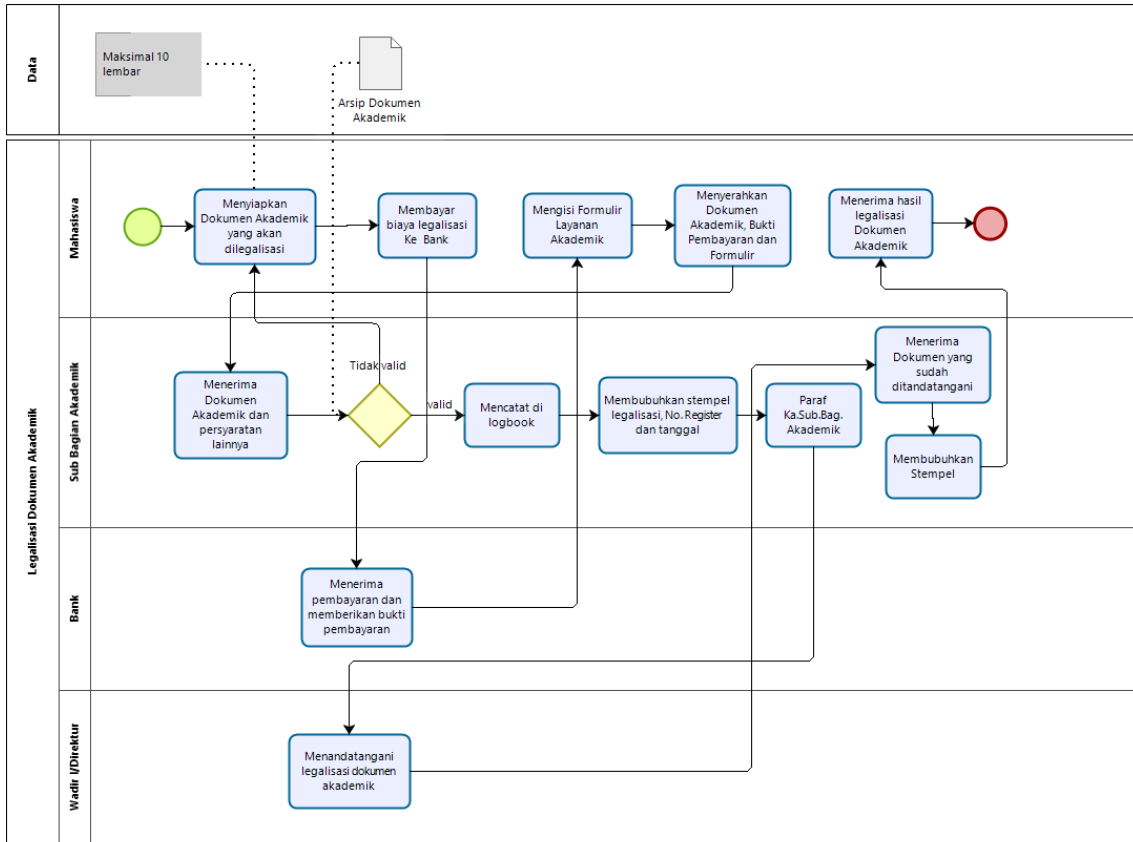

68. TRANSLATE DOKUMEN AKADEMIK

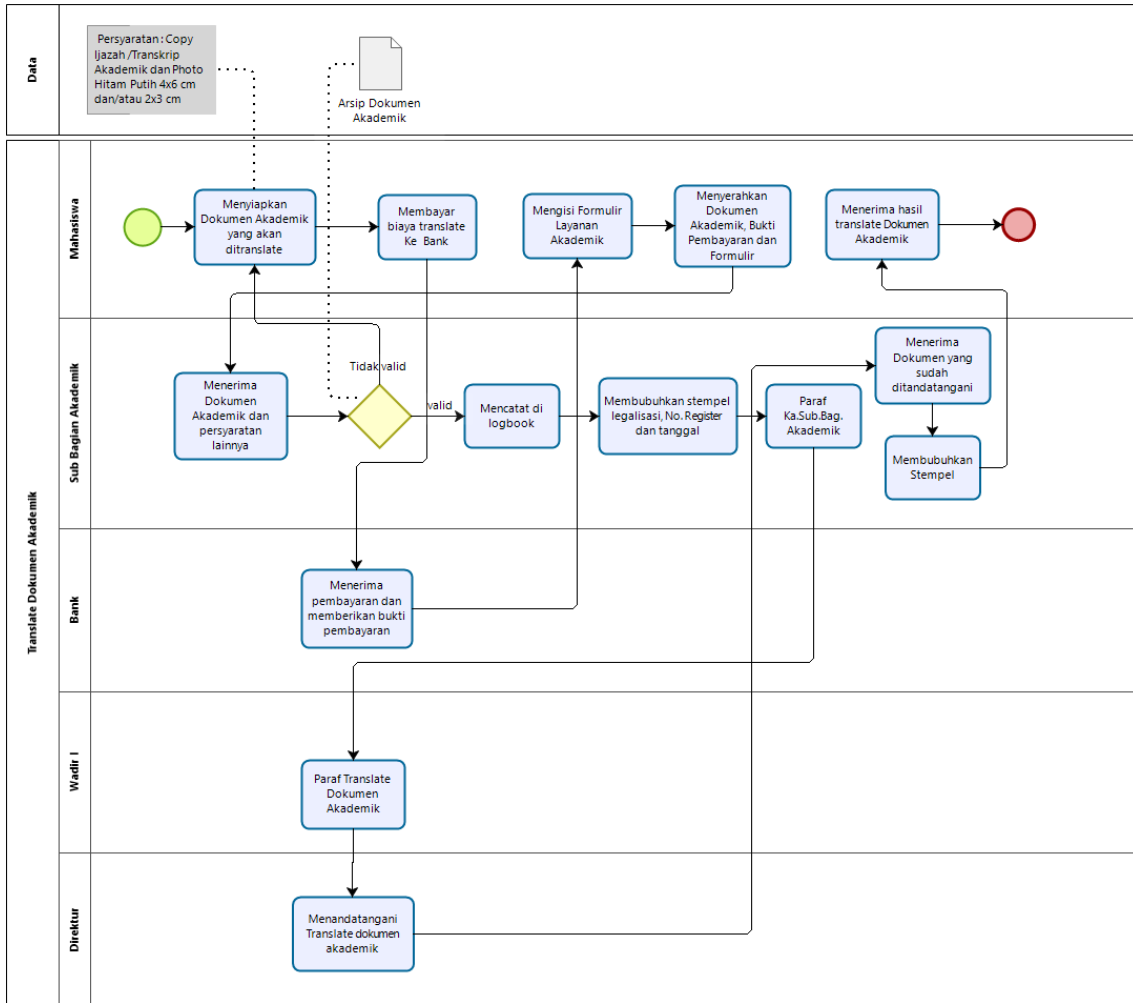

69. MENCETAK DAFTAR NILAI/TRANSKRIP

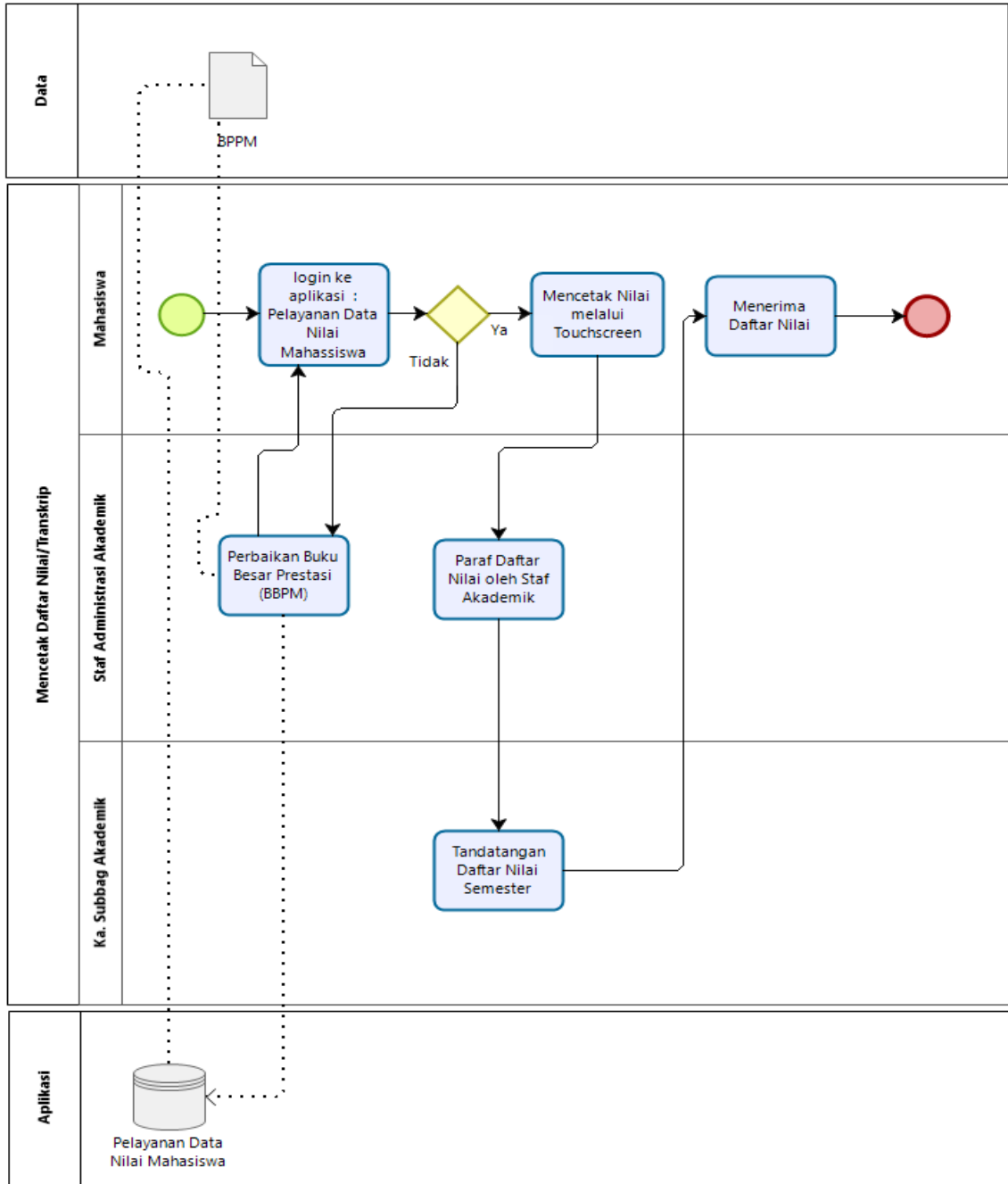

70. MENYUSUN CP SESUAI KKNI

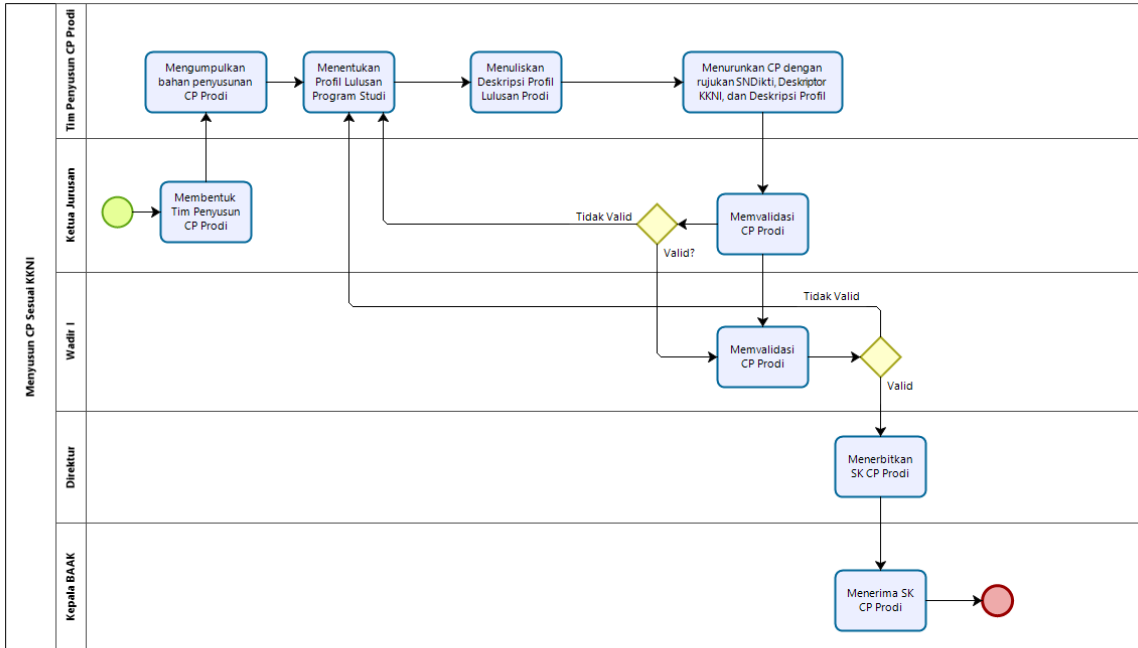

71. MENYIAPKAN DOKUMEN SKPI

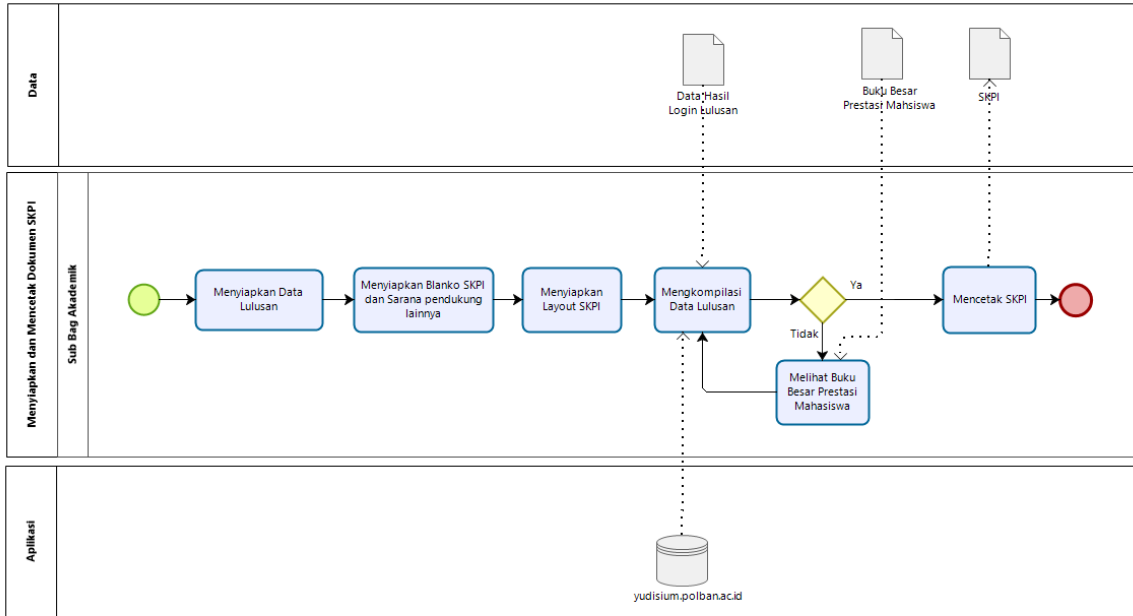

72. PEMBUATAN JADWAL UJIAN

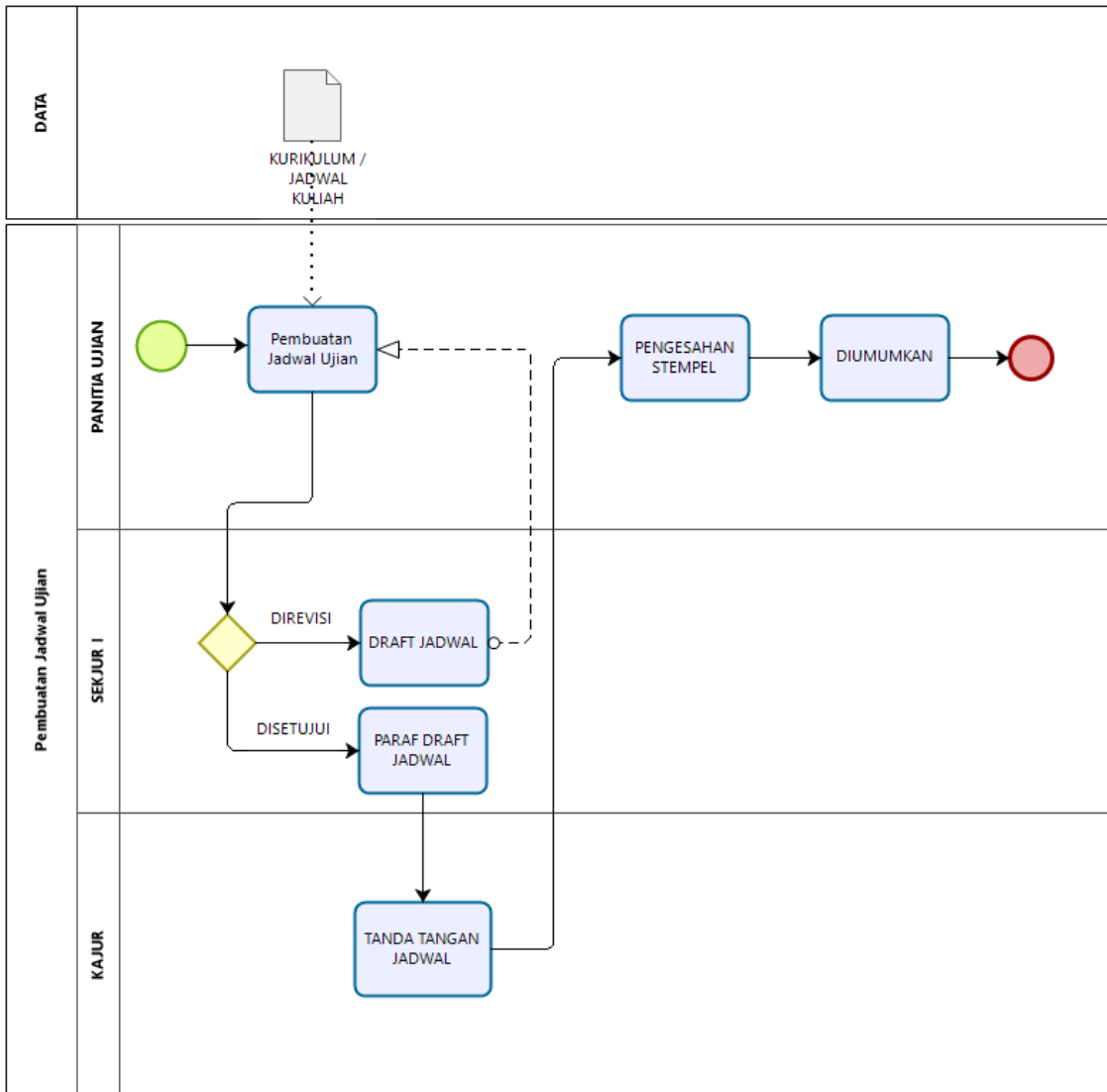

73. LAYANAN TUGAS AKHIR

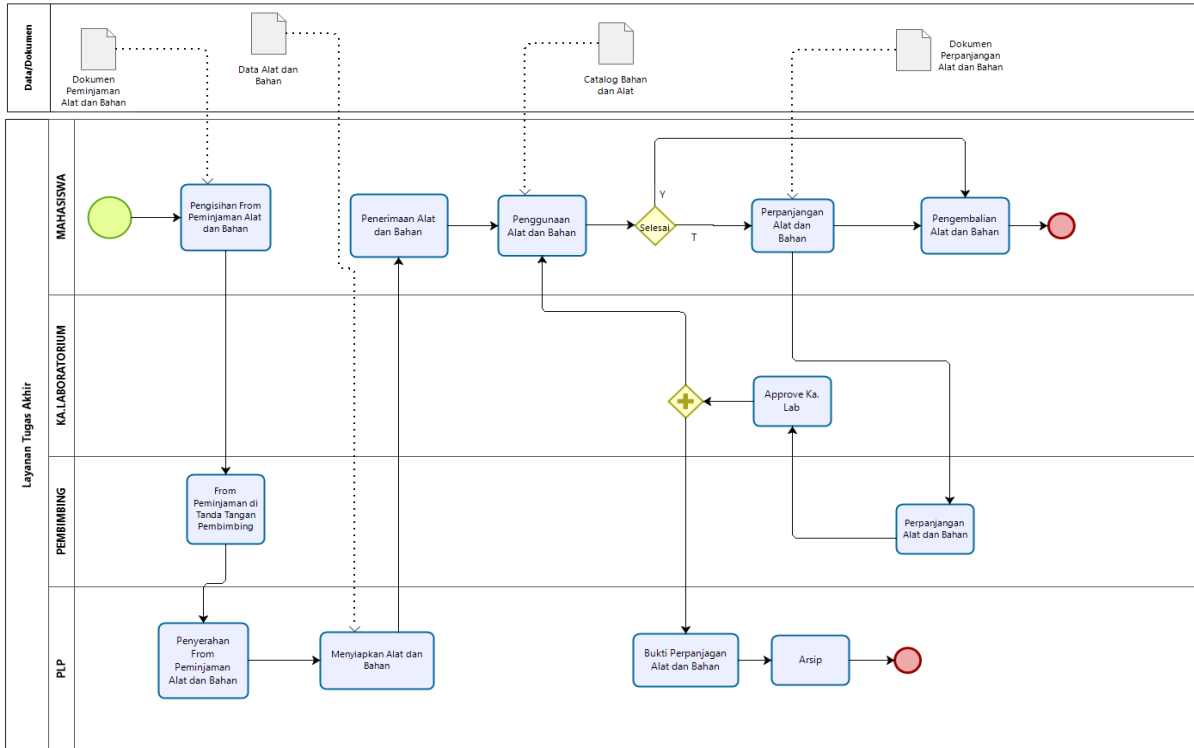

74. CETAK ABSENSI MAHASISWA

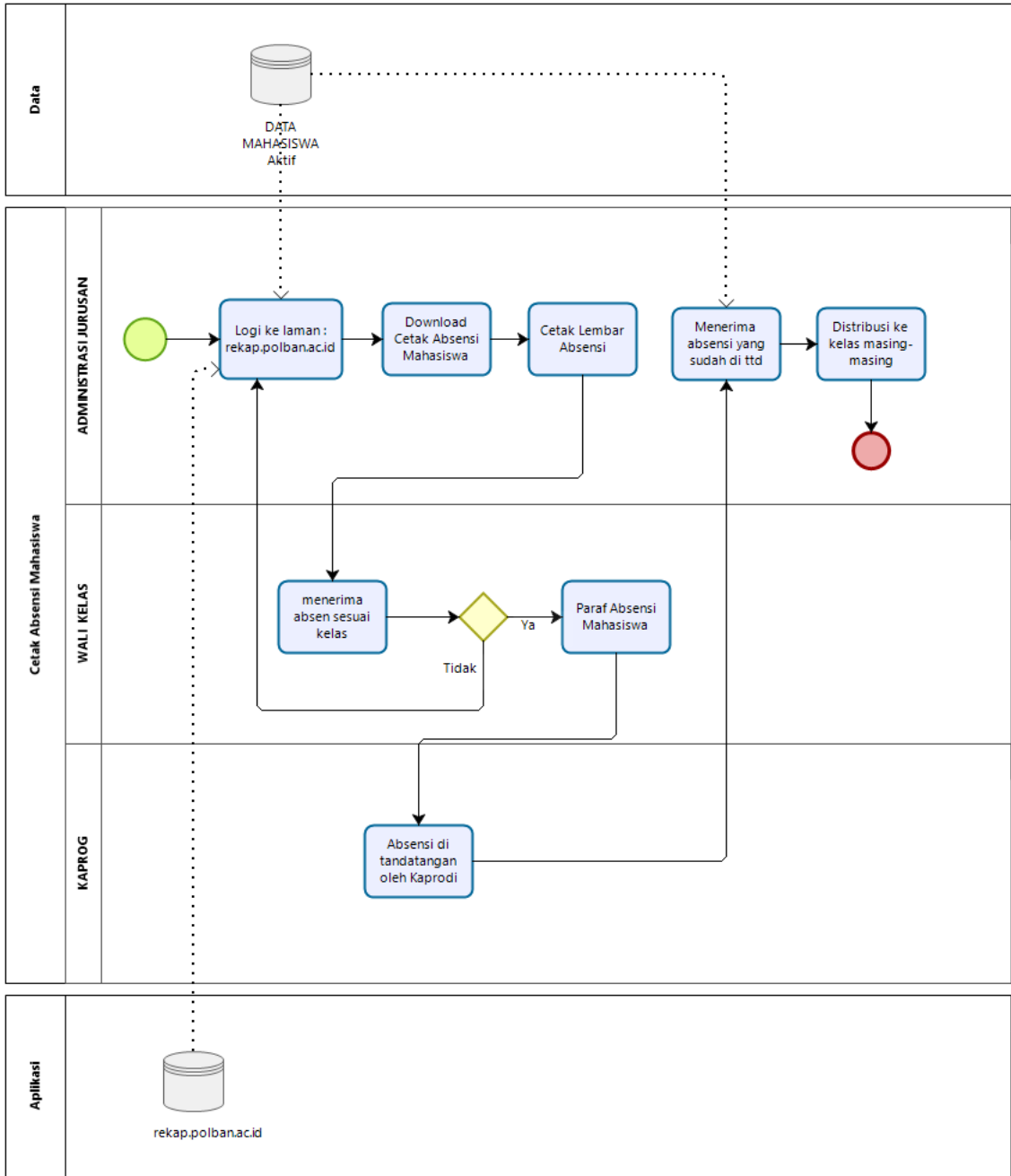

75. PENERBITAN SURAT KETERANGAN

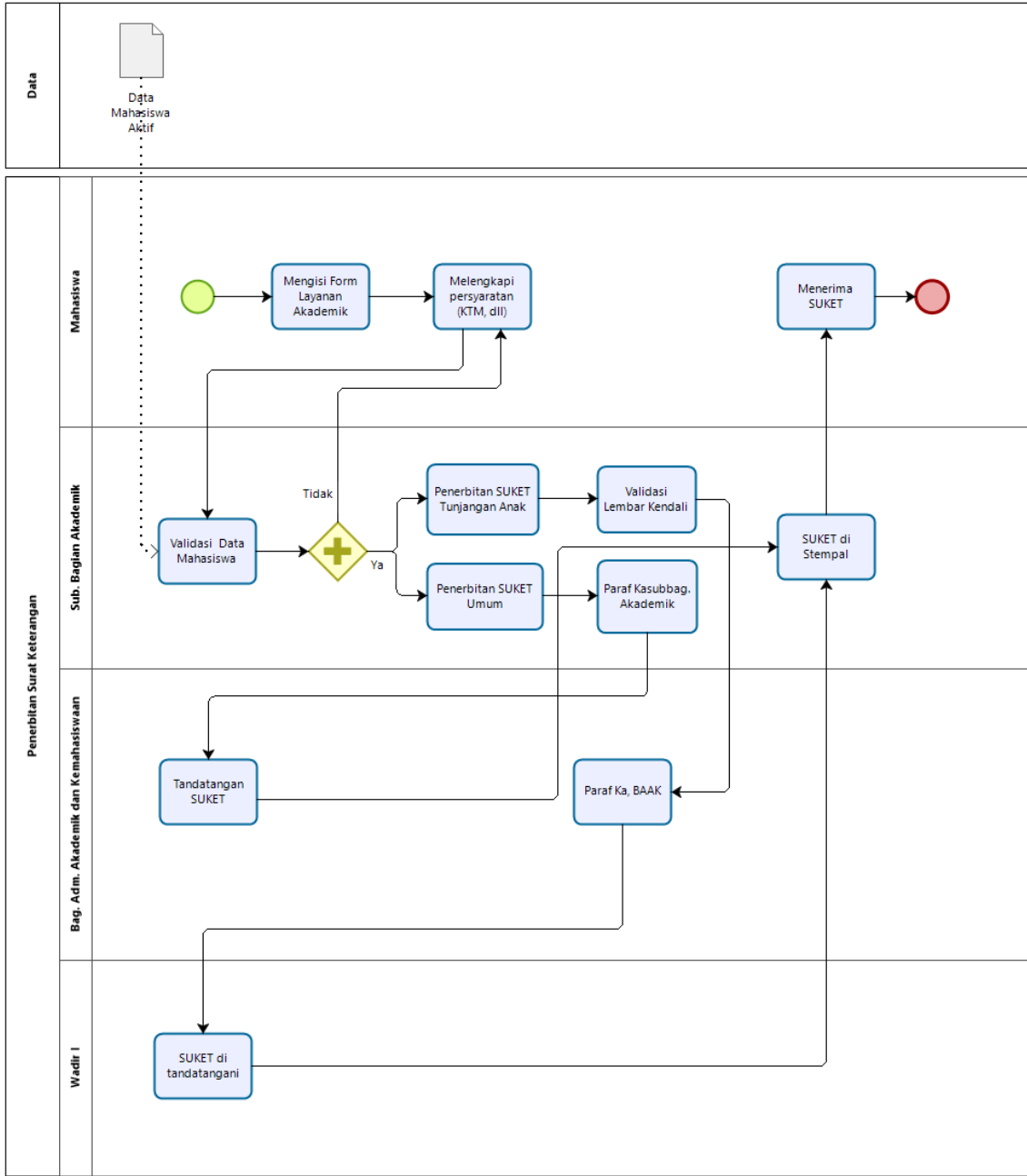

76. PENERBITAN SURAT KETERANGAN PENGGANTI IJAZAH

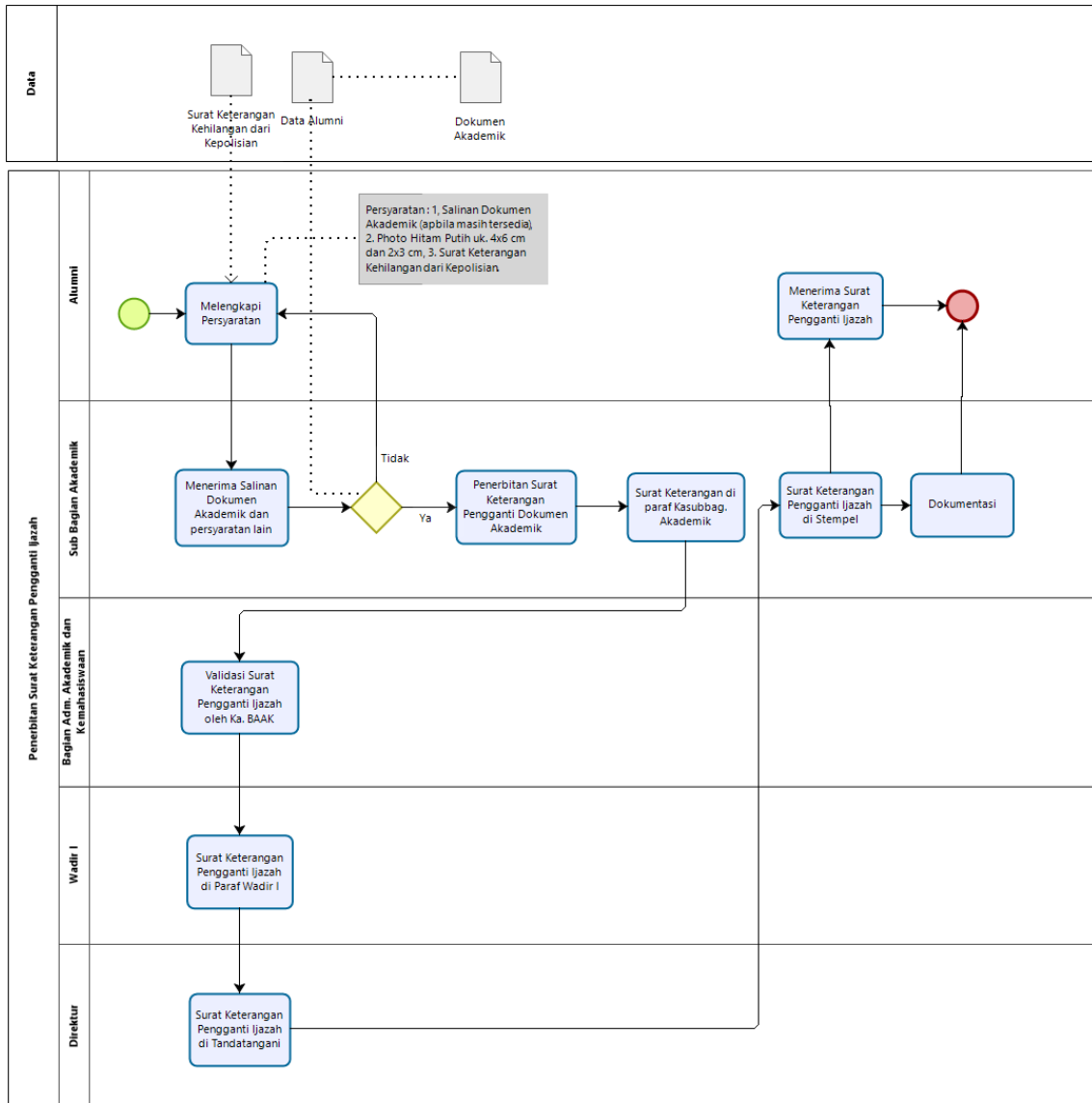

77. MENGUMPULKAN DATA AKADEMIK

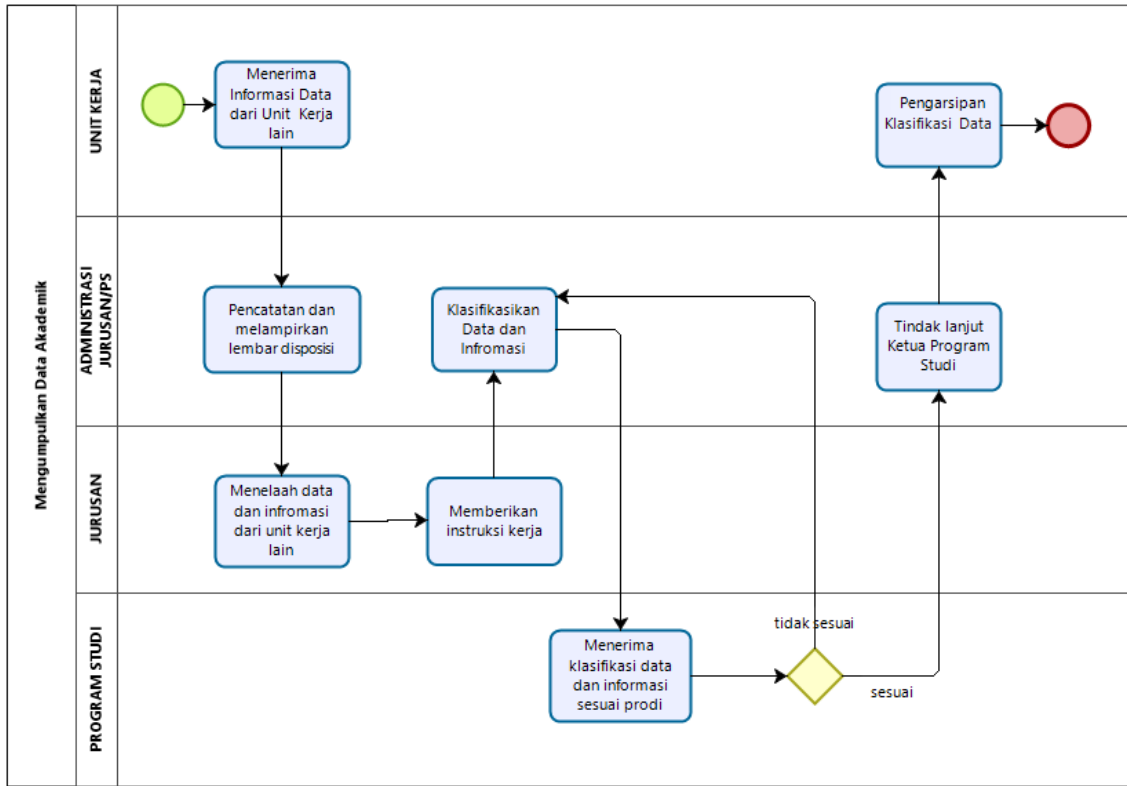

Powered by
bizagi
 Modeler

78. PENGELOLAAN PDDIKTI

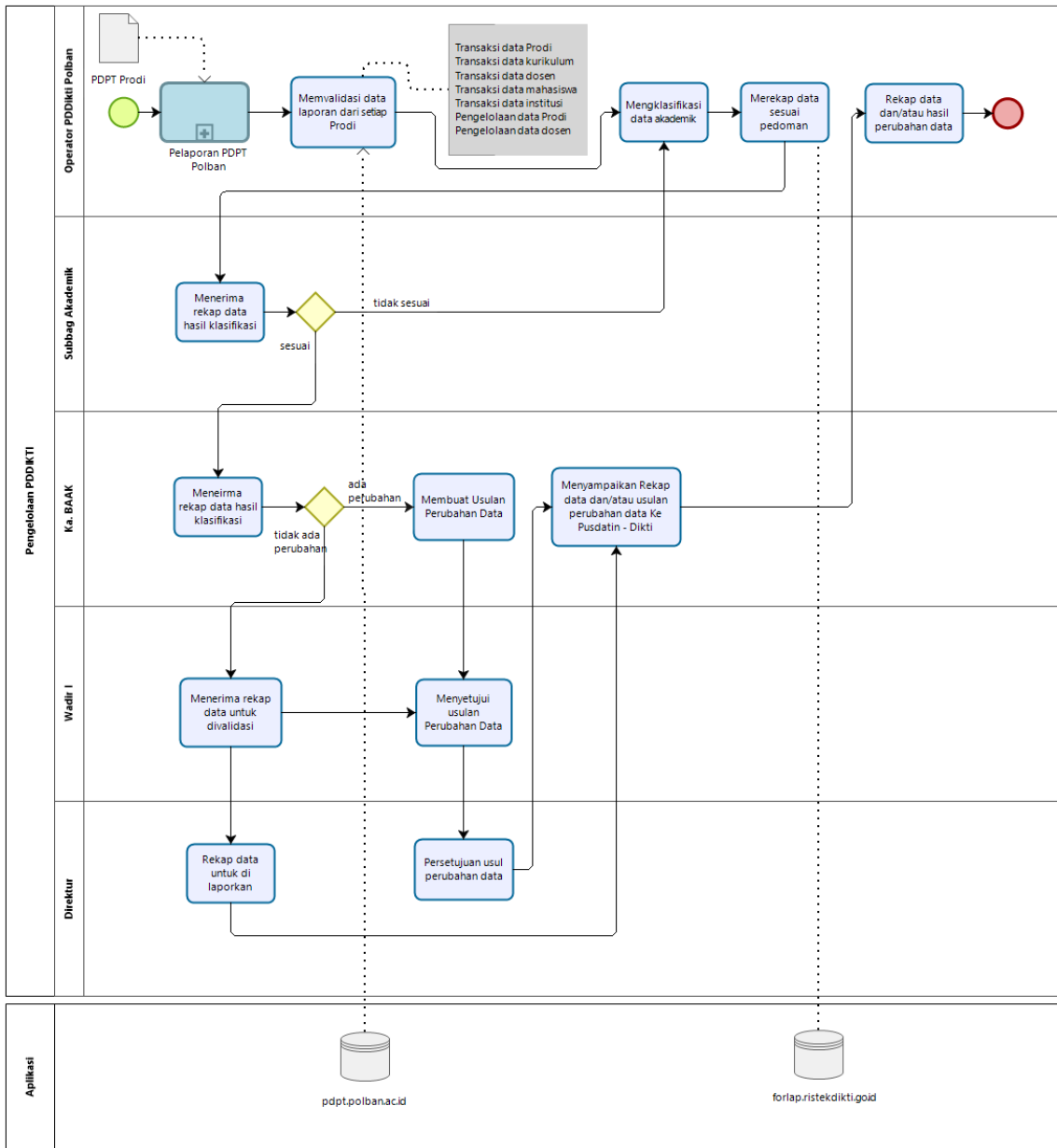

79. PERSIAPAN UJIAN

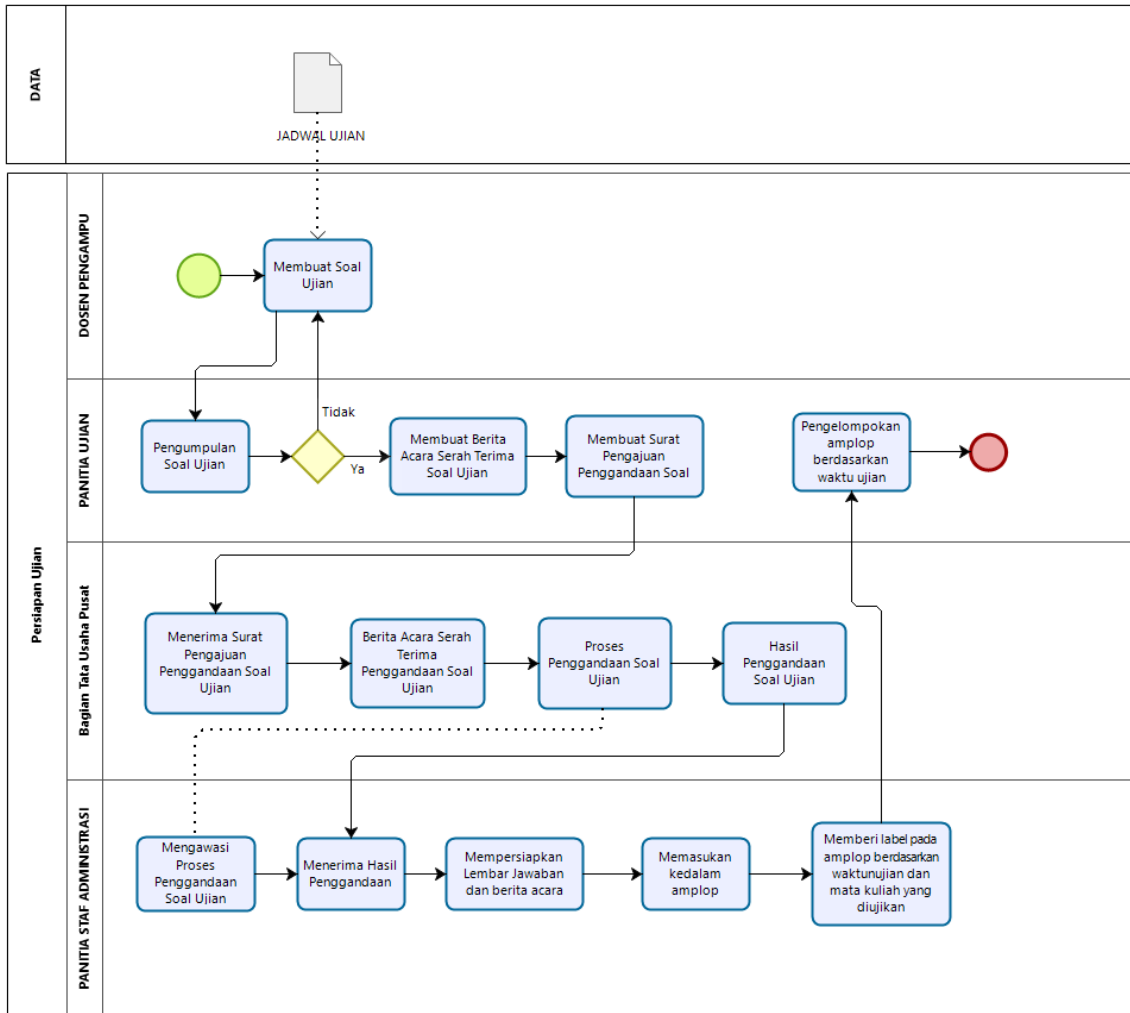

80. REKAP KEHADIRAN DOSEN

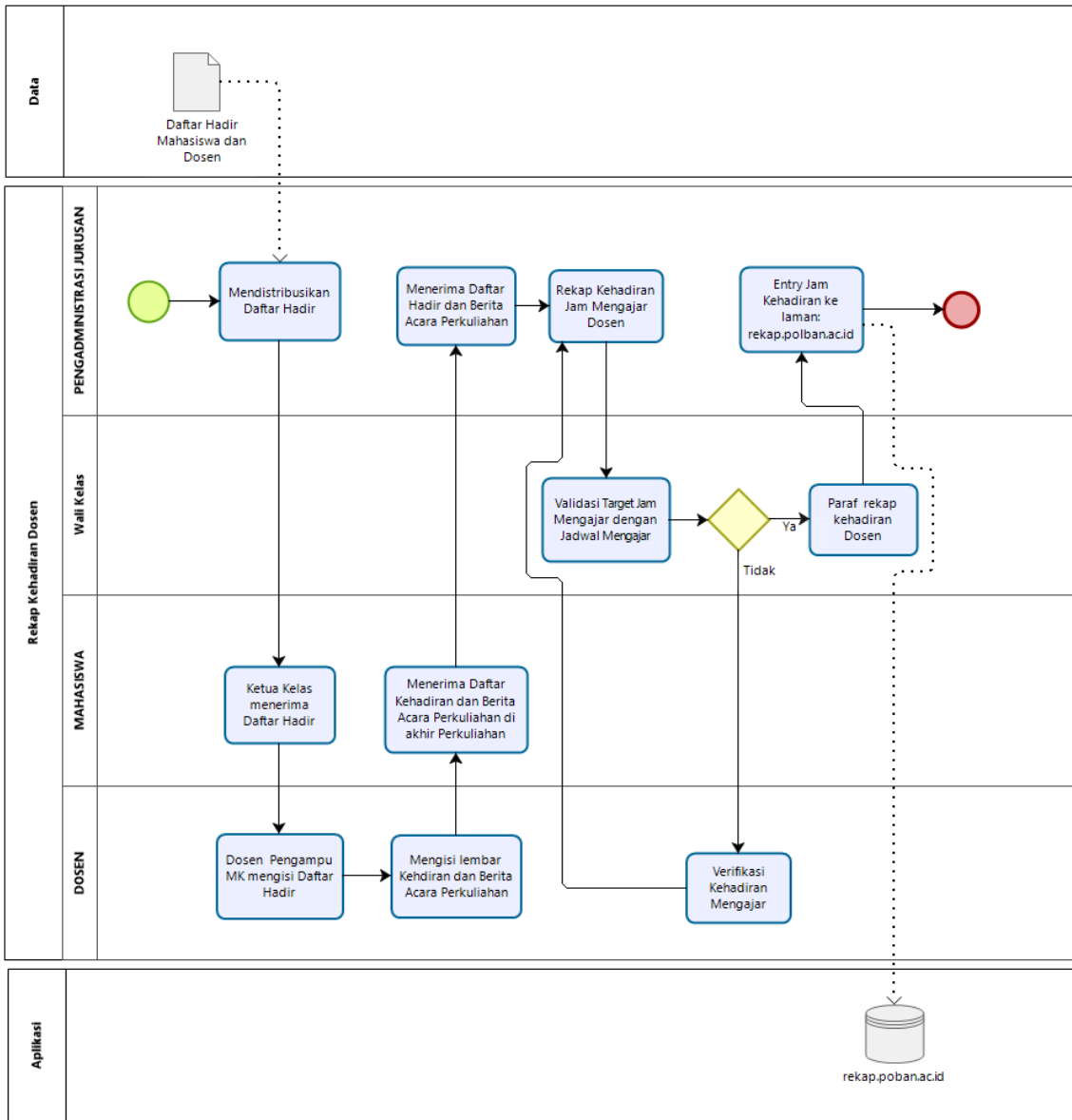

81. REKAP MENGAJAR DOSEN PARTIMER

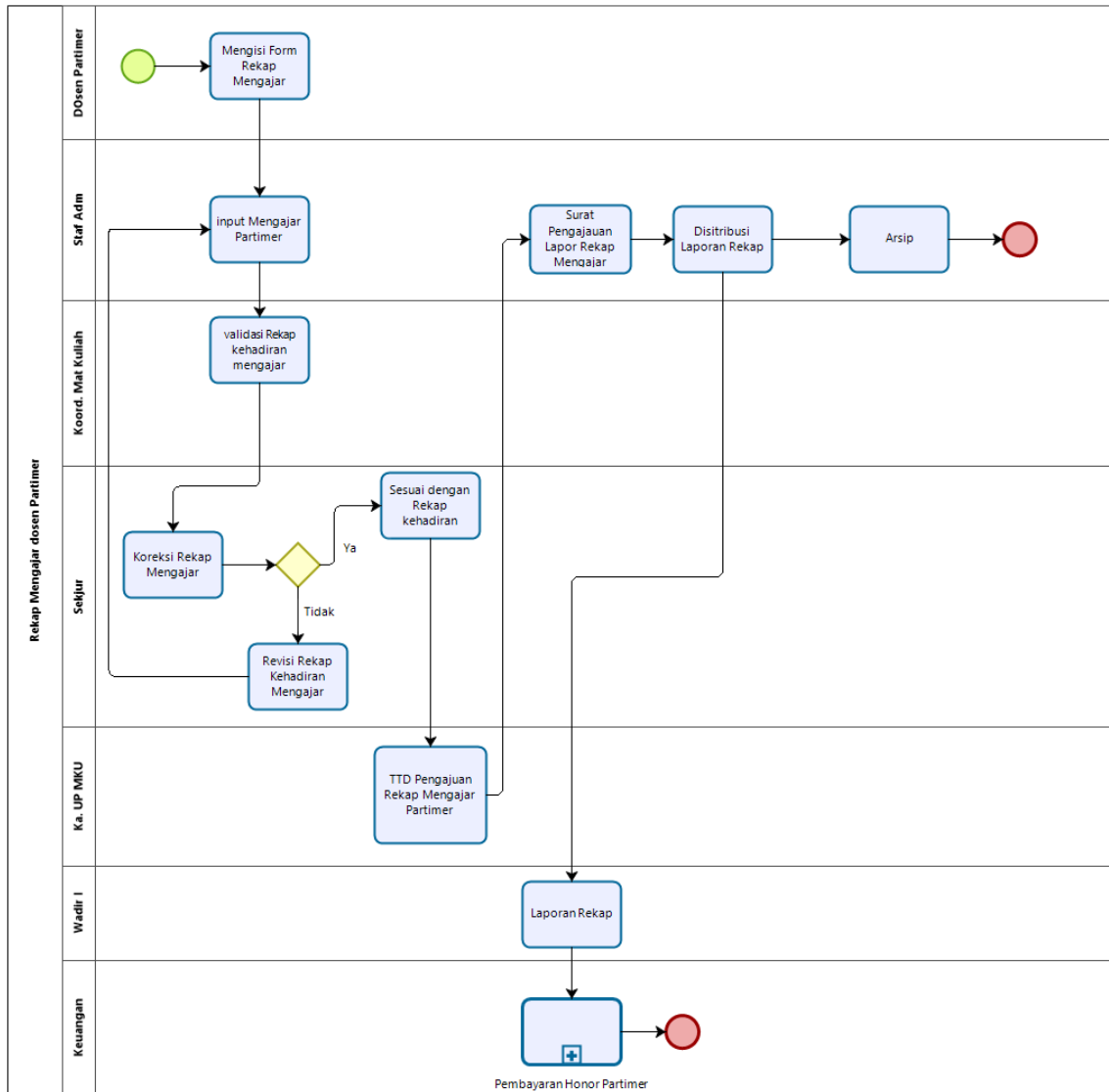

82. PRAKTIKUM DI LABORATORIUM

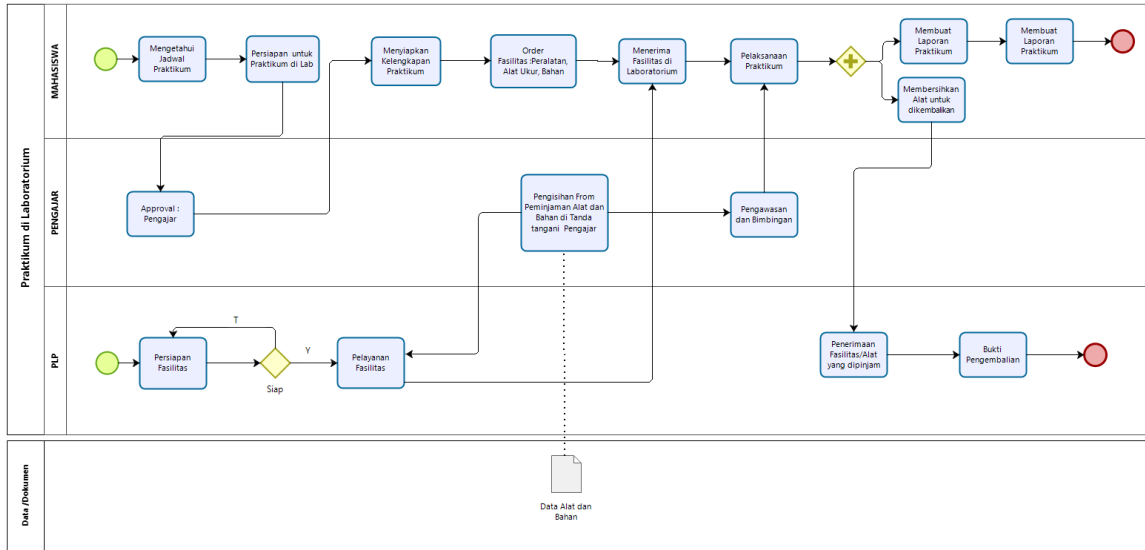

83. PEMINJAMAN ALAT DI LABORATORIUM

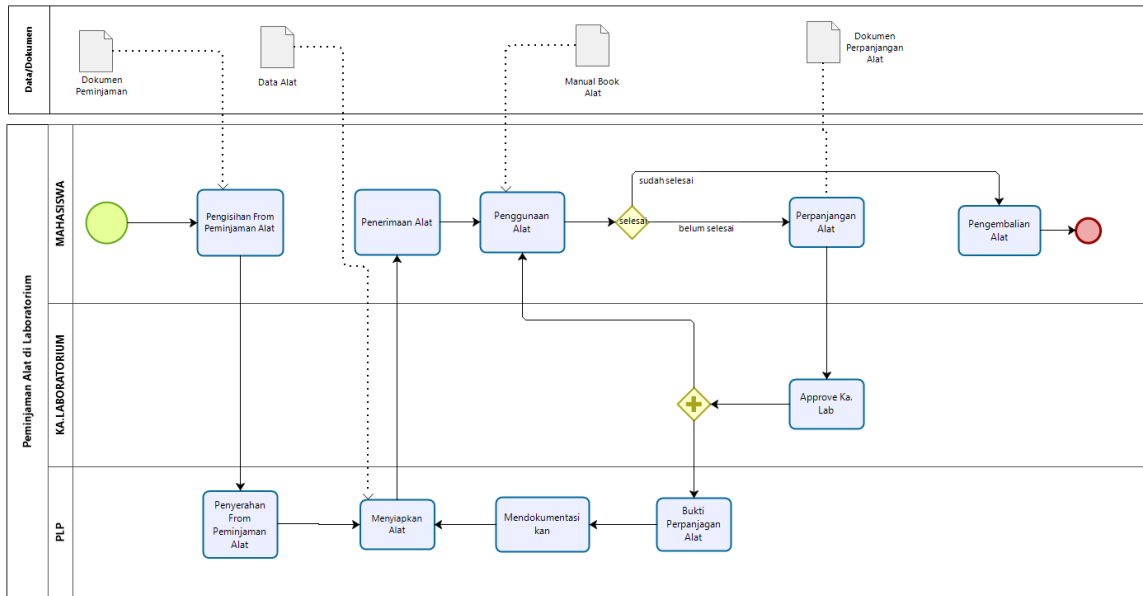

Powered by bizagi Modeler

84. PEMINJAMAN BAHAN DI LABORATORIUM

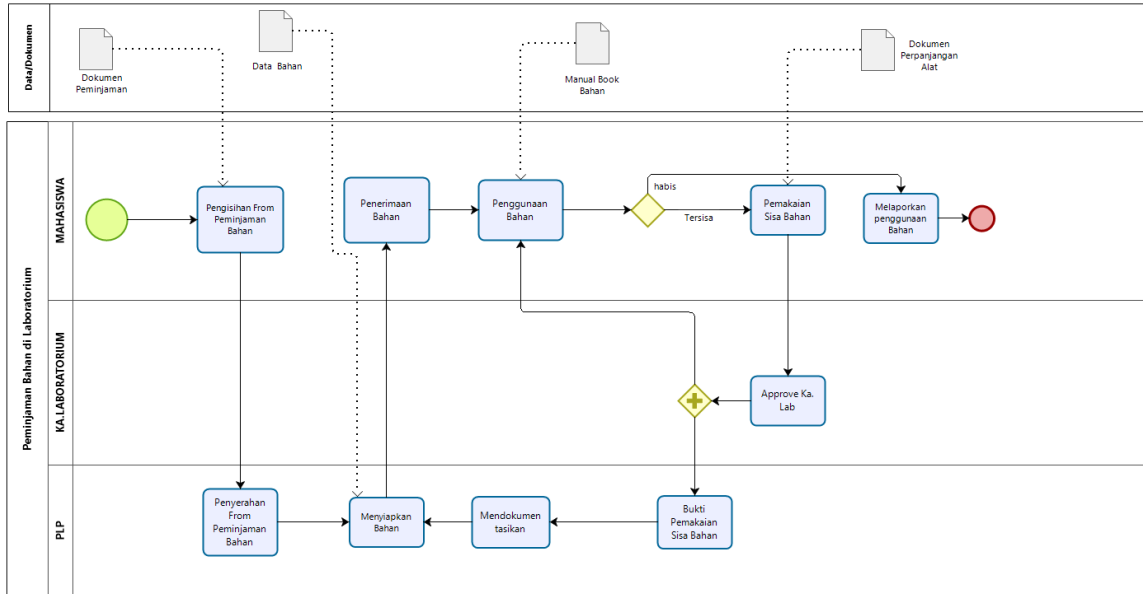

85. PENILAIAN KARYA ILMIAH DOSEN

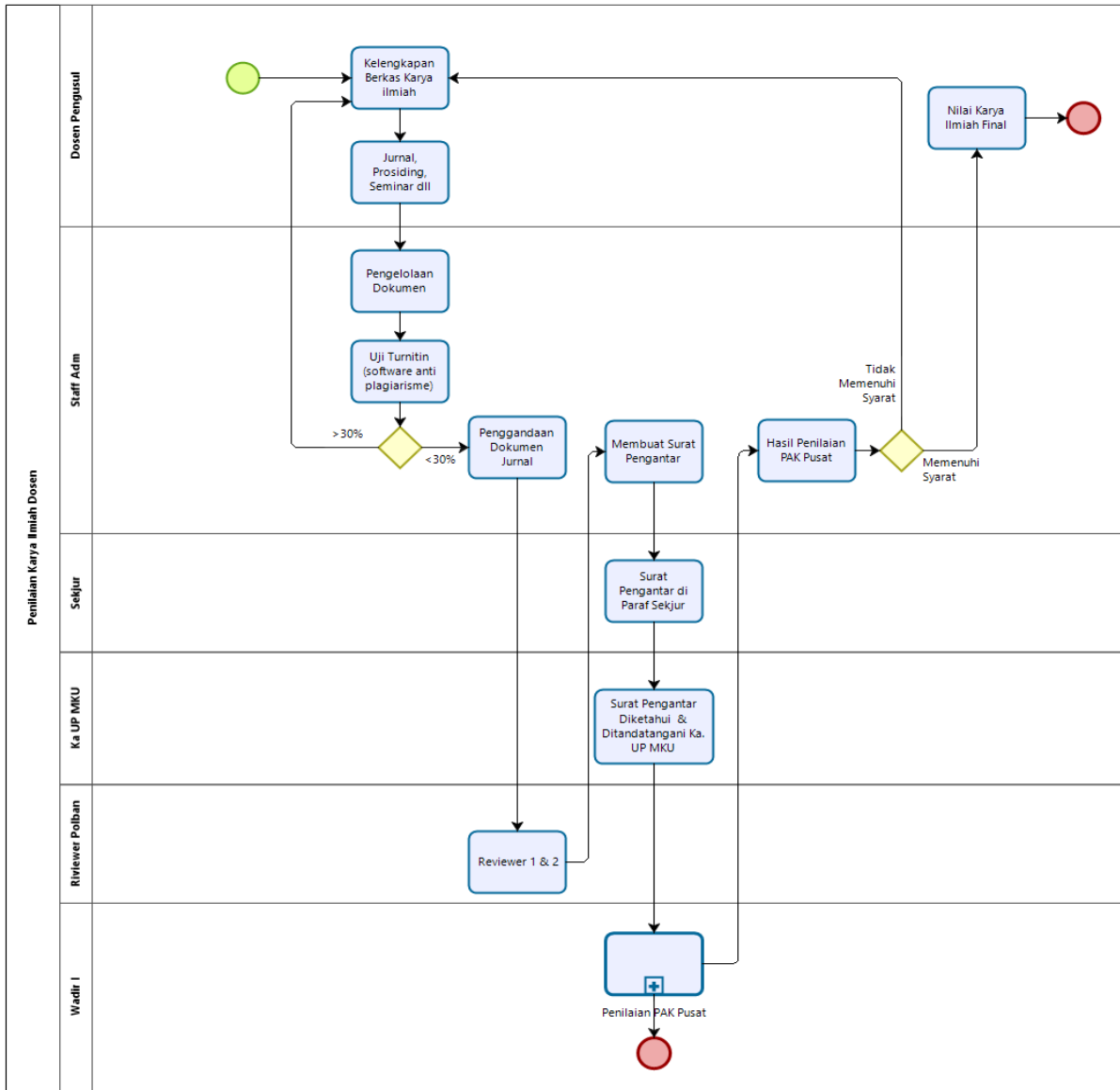

86. REKAPITULASI & OLAH DATA

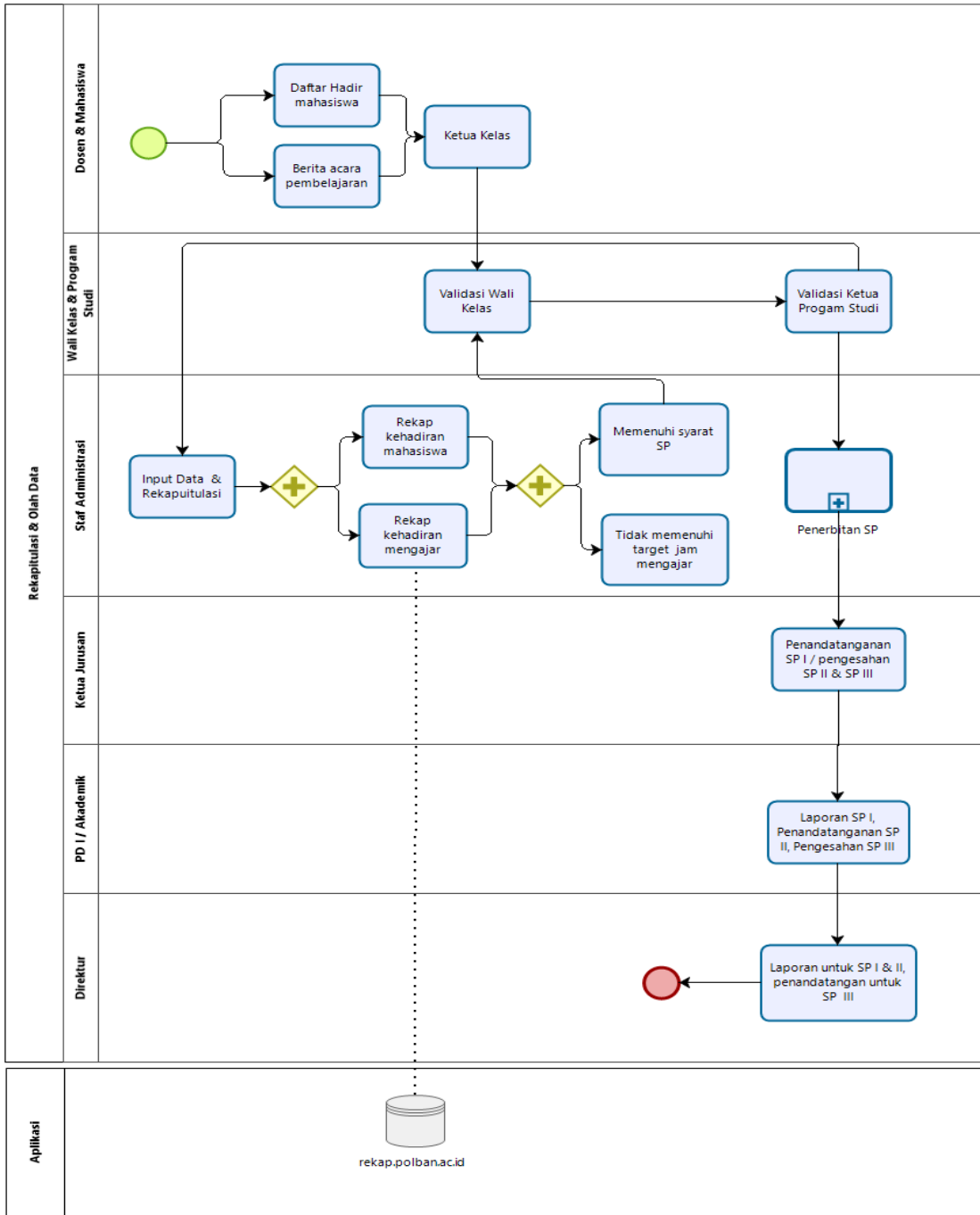

87. SERTIFIKASI DOSEN

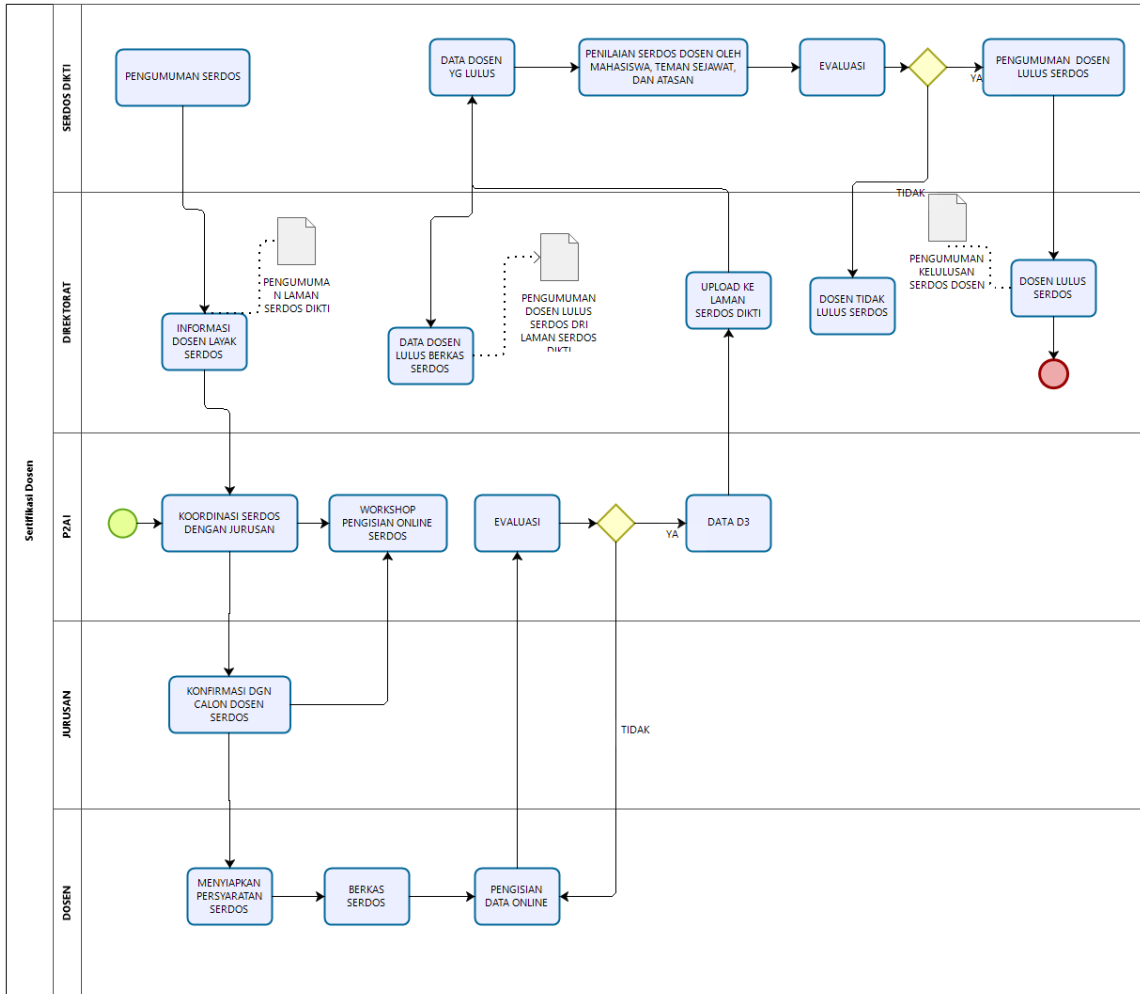

88. EVALUASI KELULUSAN/YUDISIUM

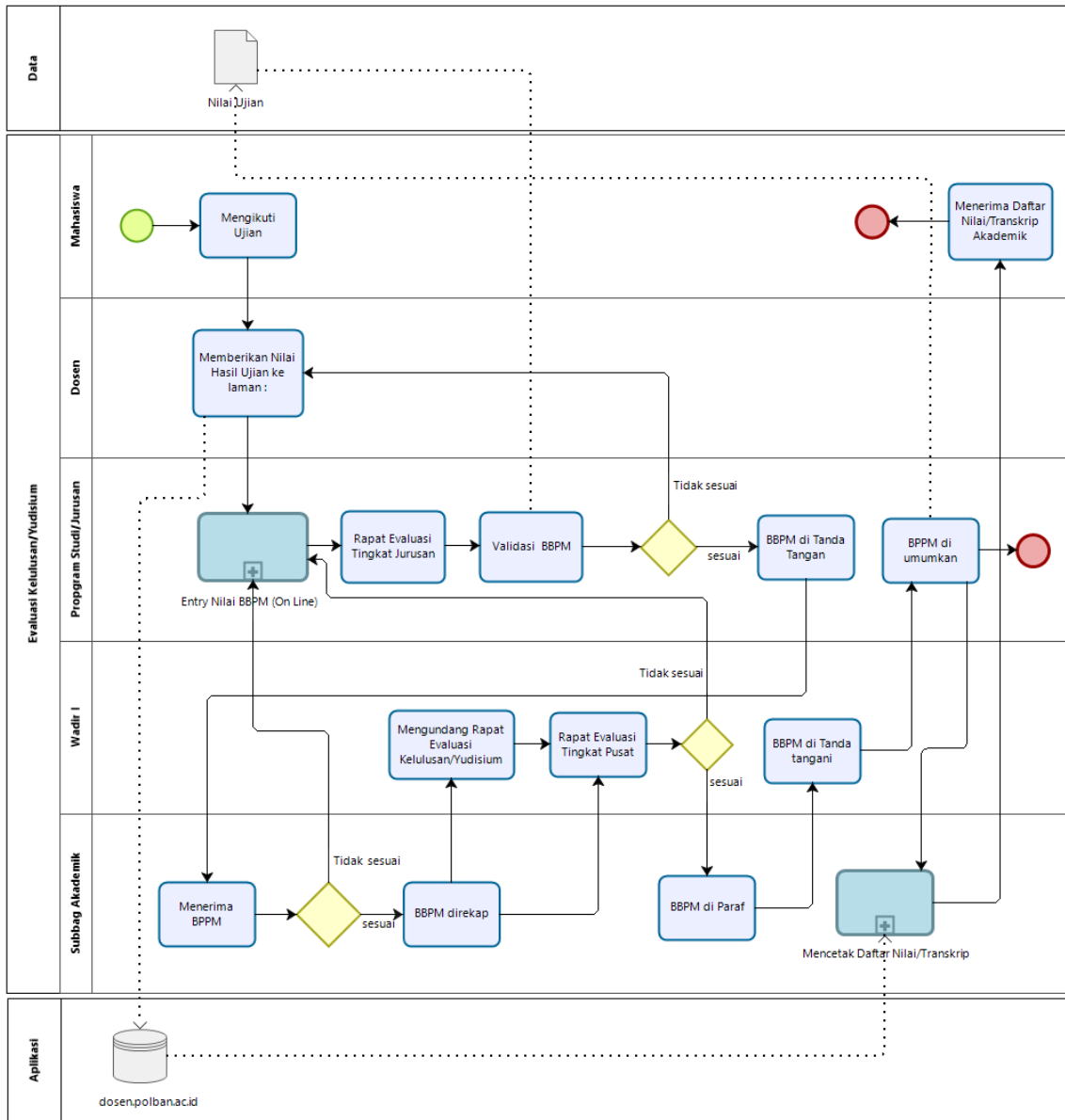

89. CAPAIAN HASIL BELAJAR MAHASISWA

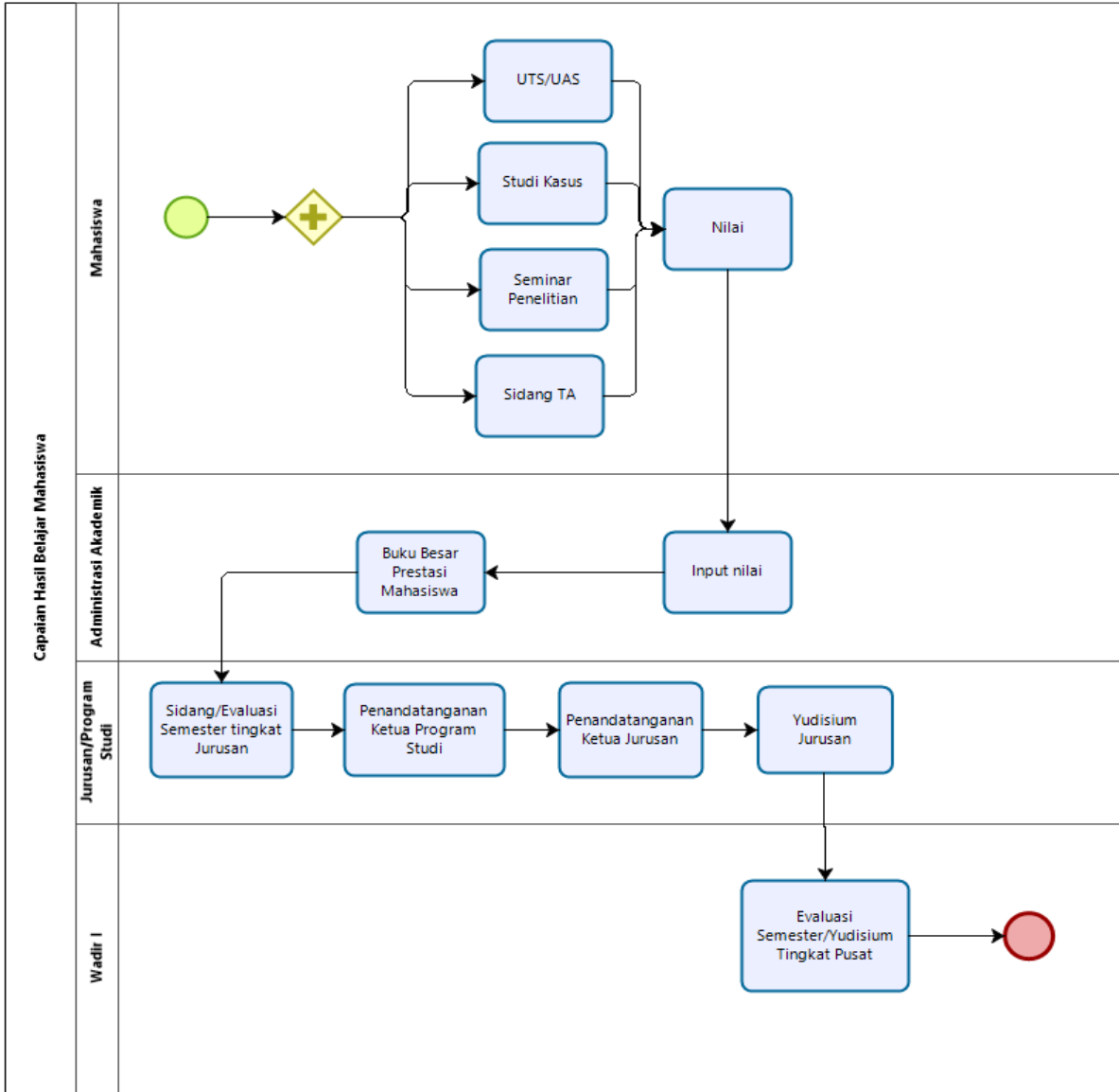

90. ADMINISTRASI WISUDA

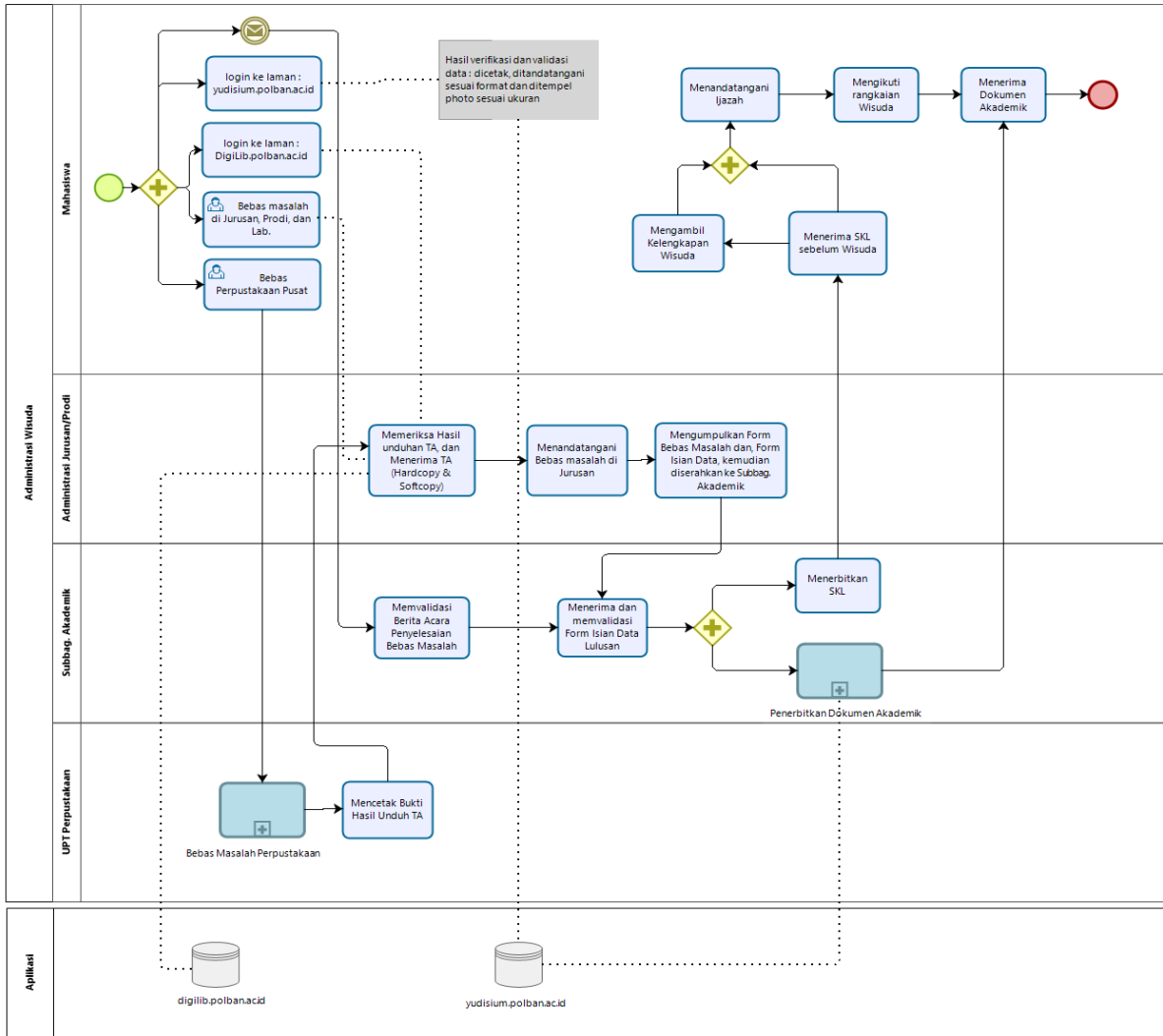

91. LAYANAN ADMINISTRASI PERENCANAAN DAN SISTEM INFORMASI



Powered by
bizagi
Modeler

92. PENGELOLAAN SARANA TEKNOLOGI INFORMASI DAN KOMUNIKASI

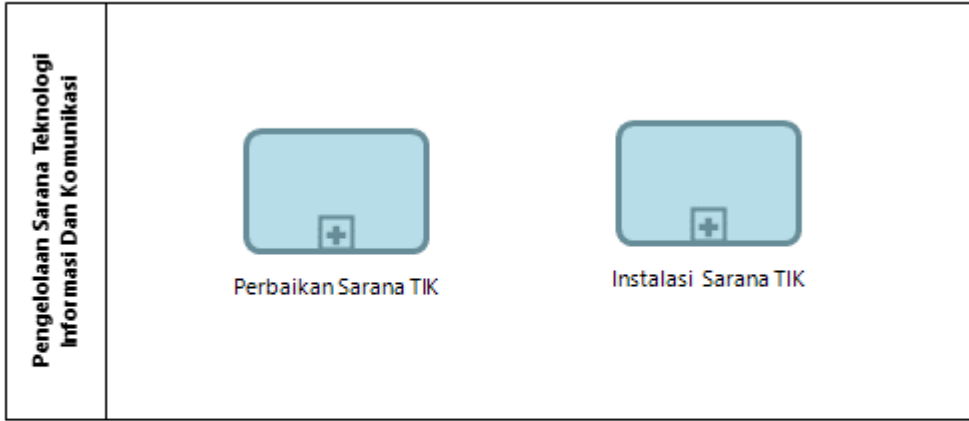

Powered by
bizagi
Modeler

93. PERBAIKAN SARANA TIK

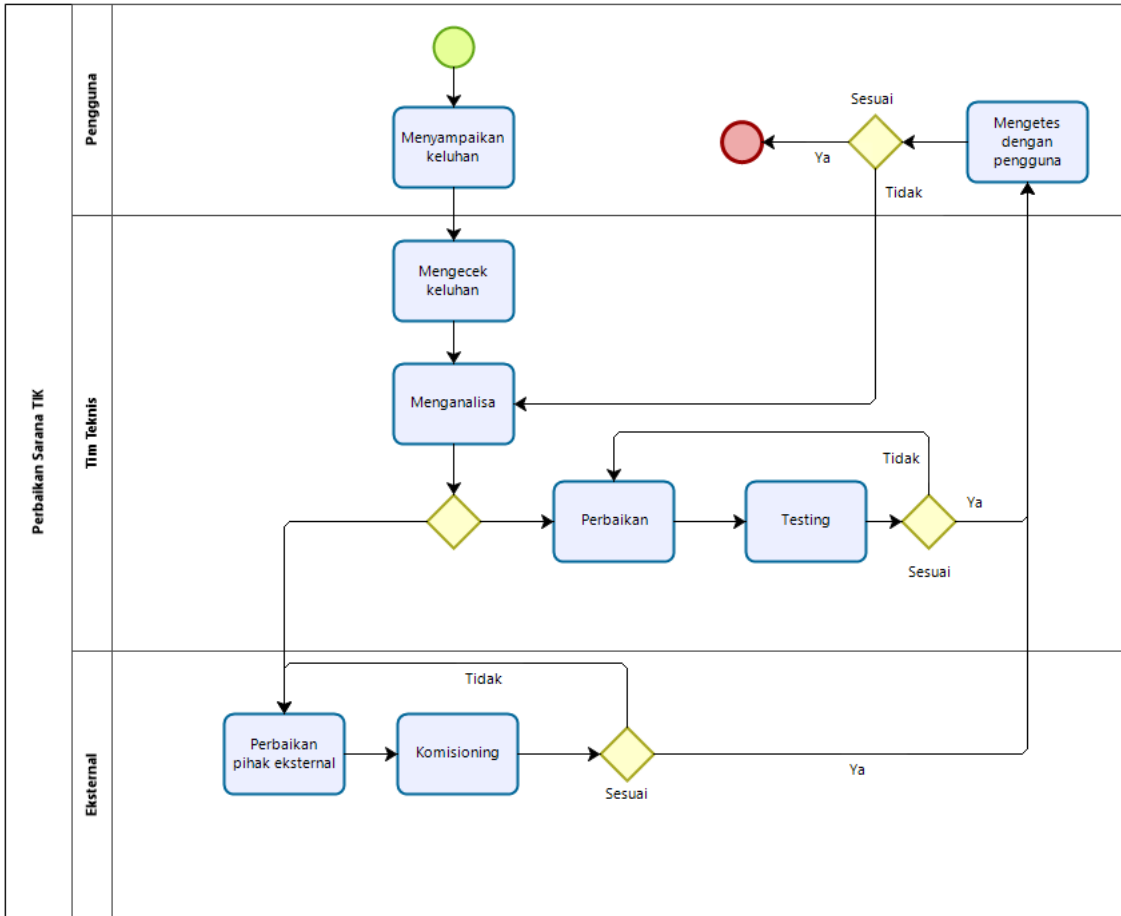

94. INSTALASI SARANA TIK

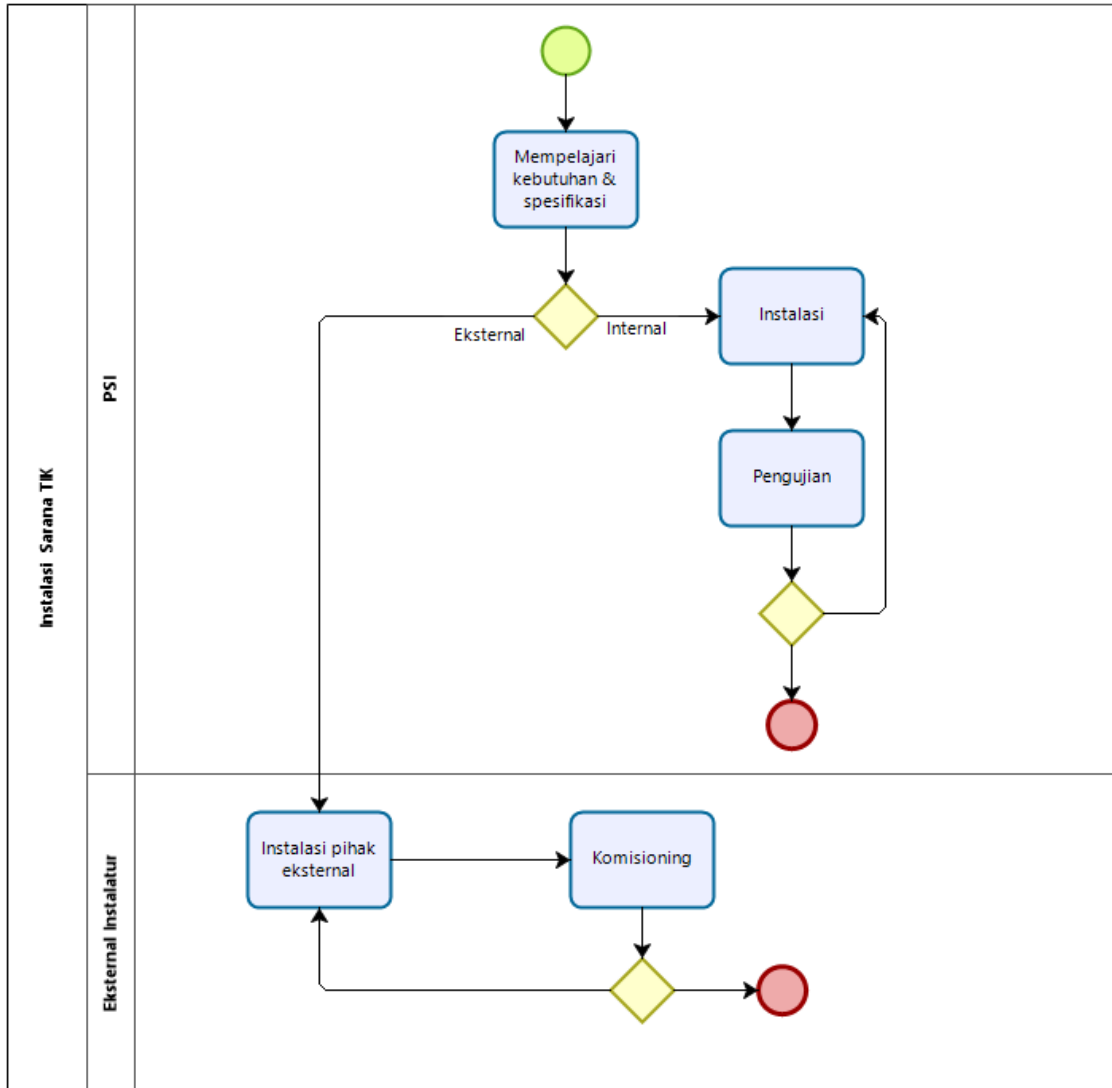

95. PENGEMBANGAN SISTEM INFORMASI

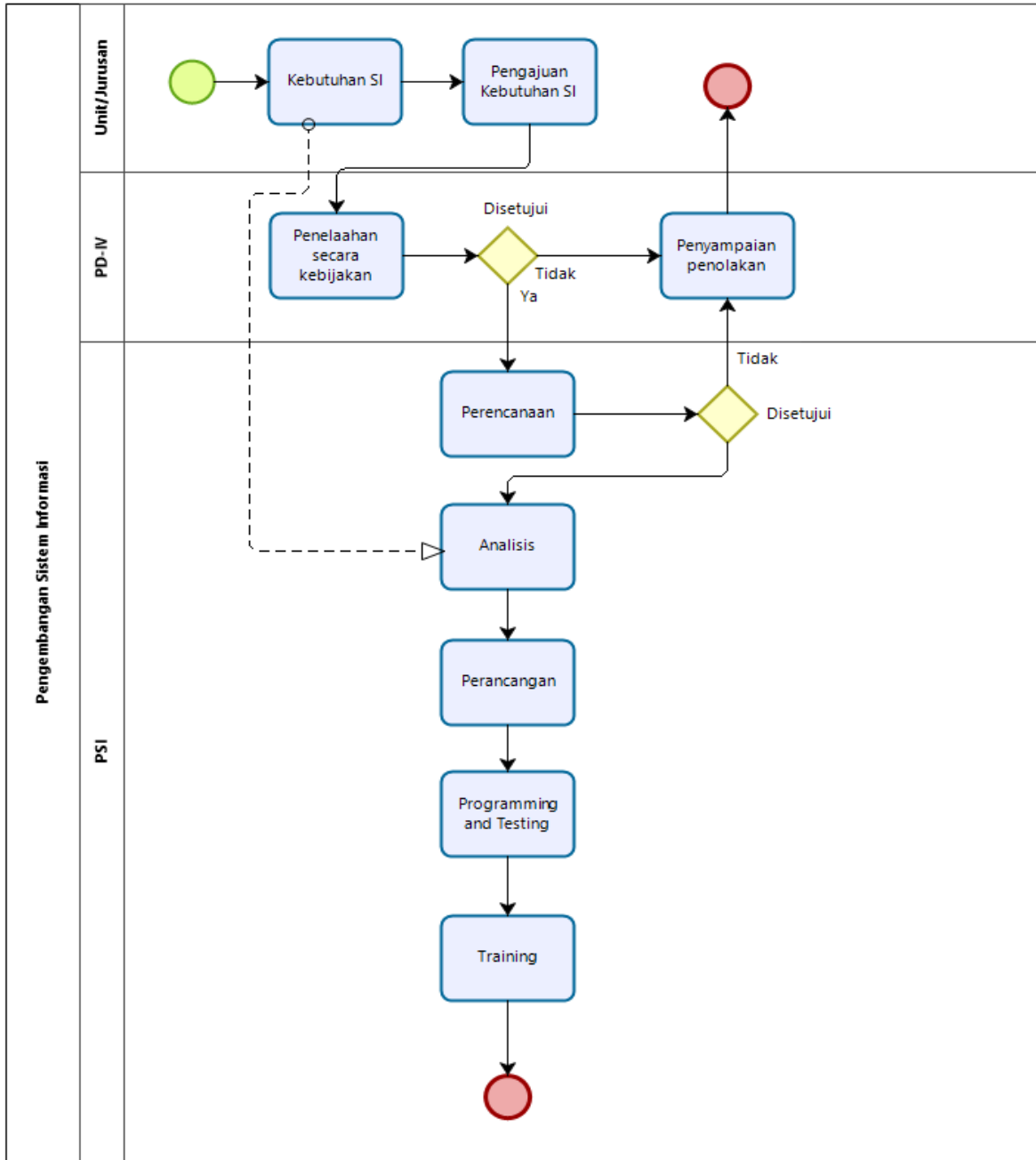

96. PENGELOLAAN JARINGAN



97. PASANG BARU JARINGAN

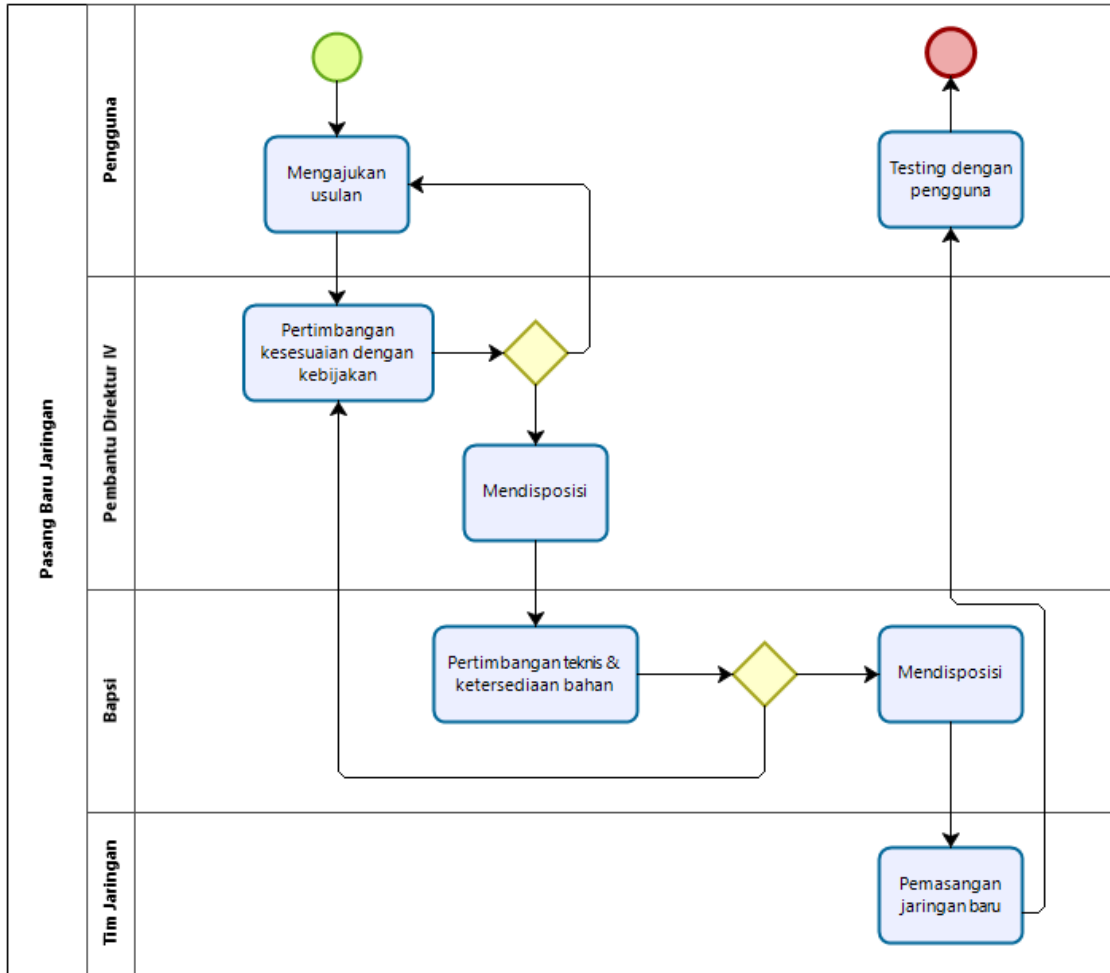

98. PERBAIKAN JARINGAN

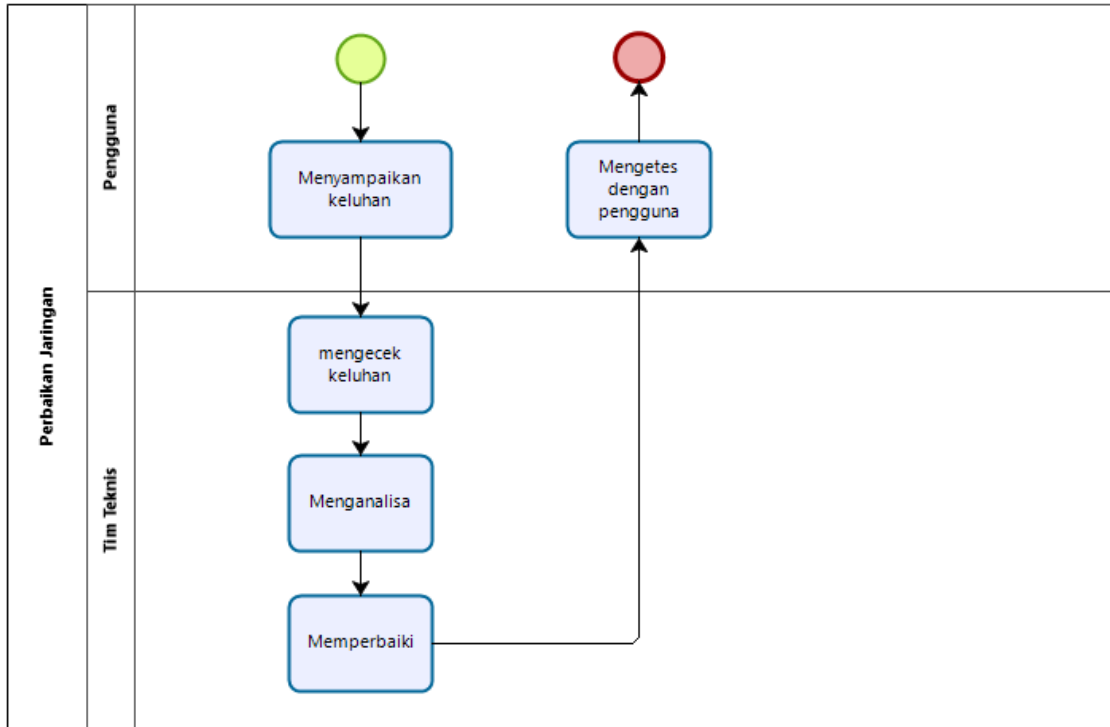

99. PENGELOLAAN WEB

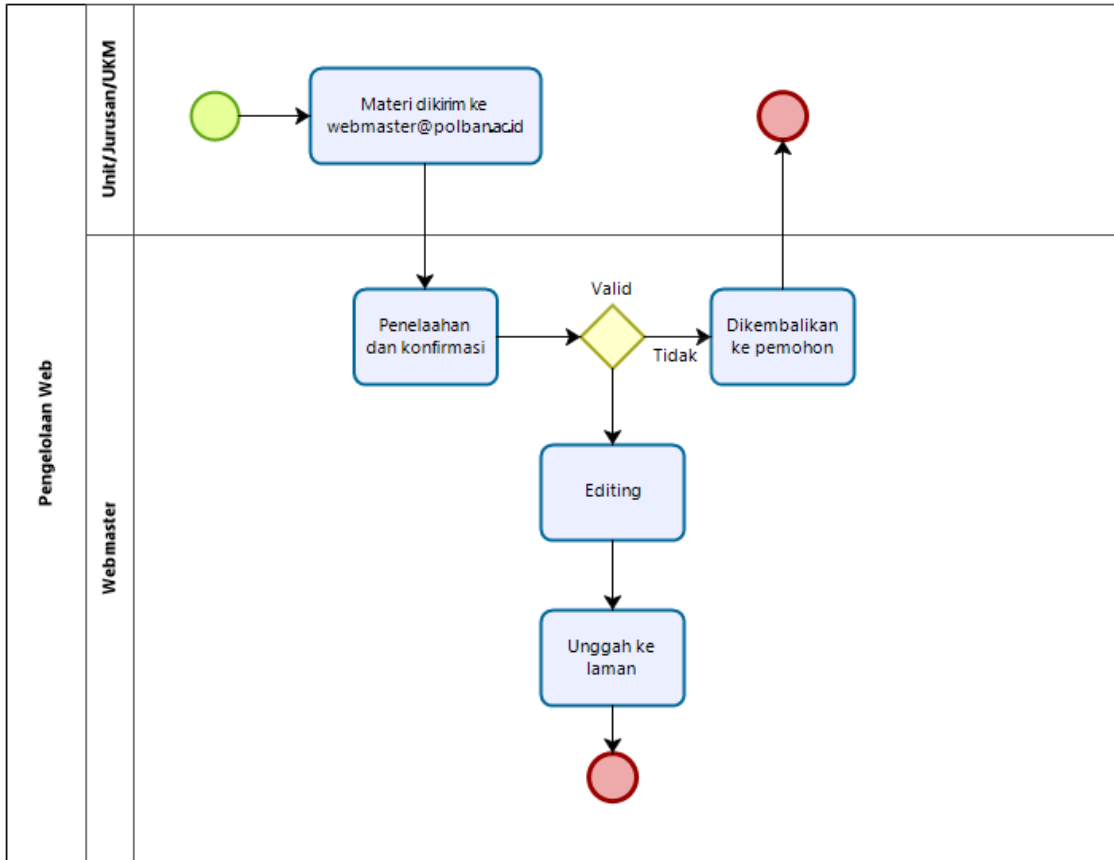

100. LAYANAN EMAIL

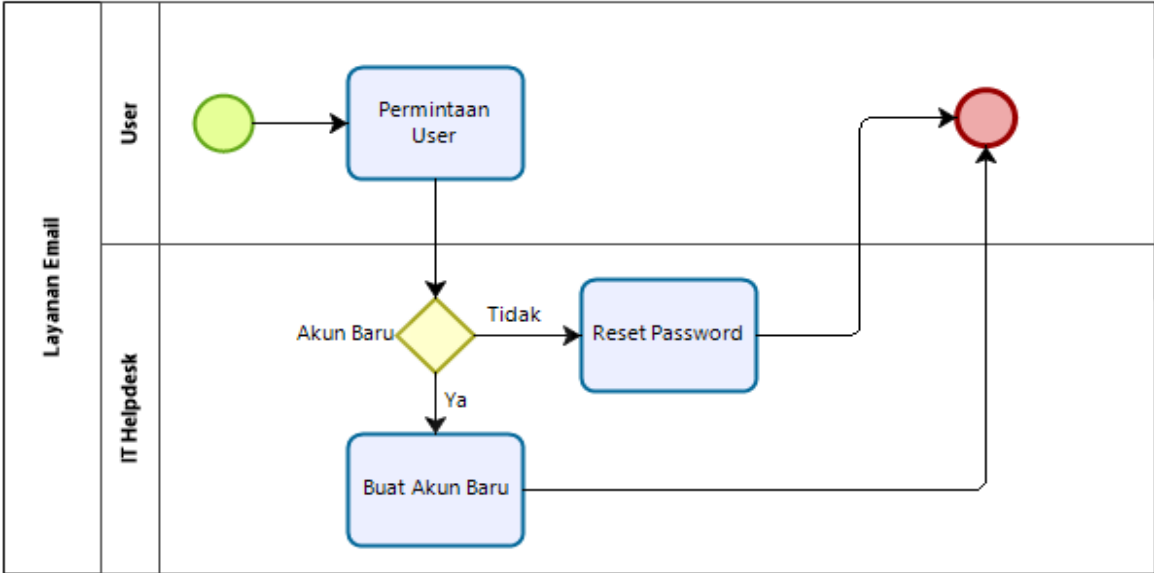

101. LAYANAN HOSTING

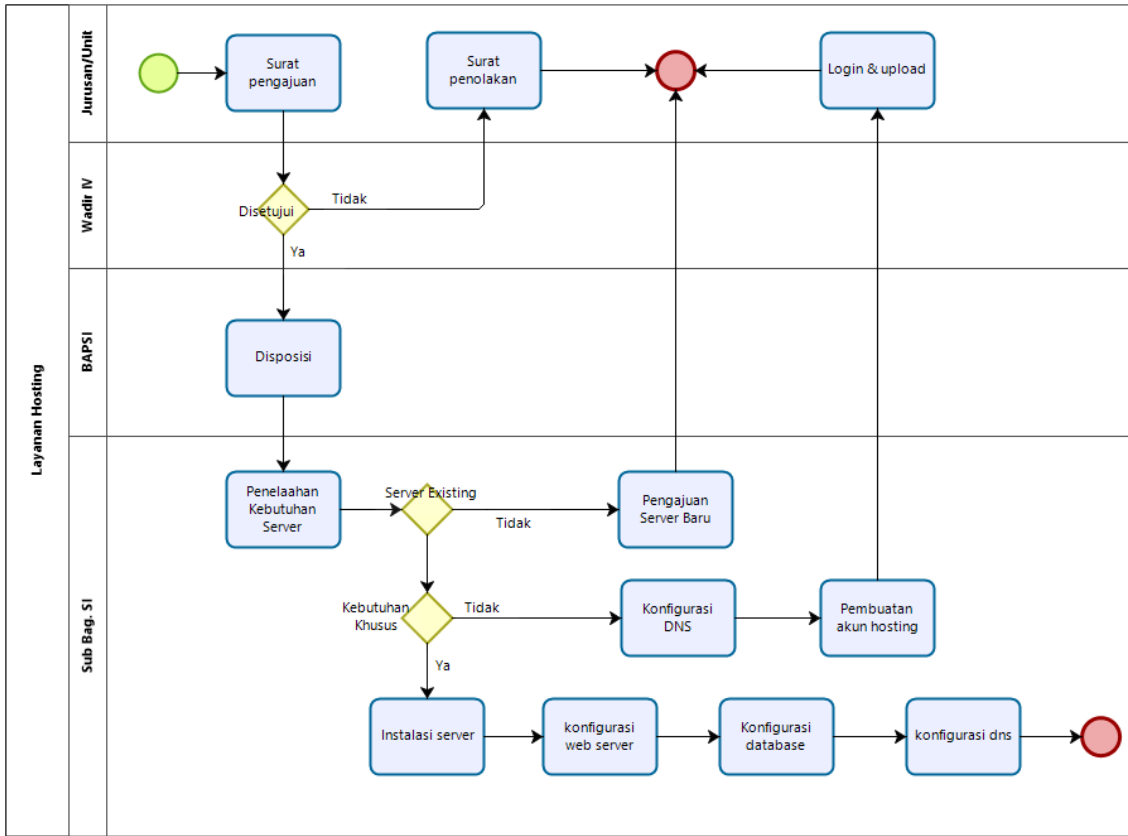

102. PERENCANAAN ANGGARAN

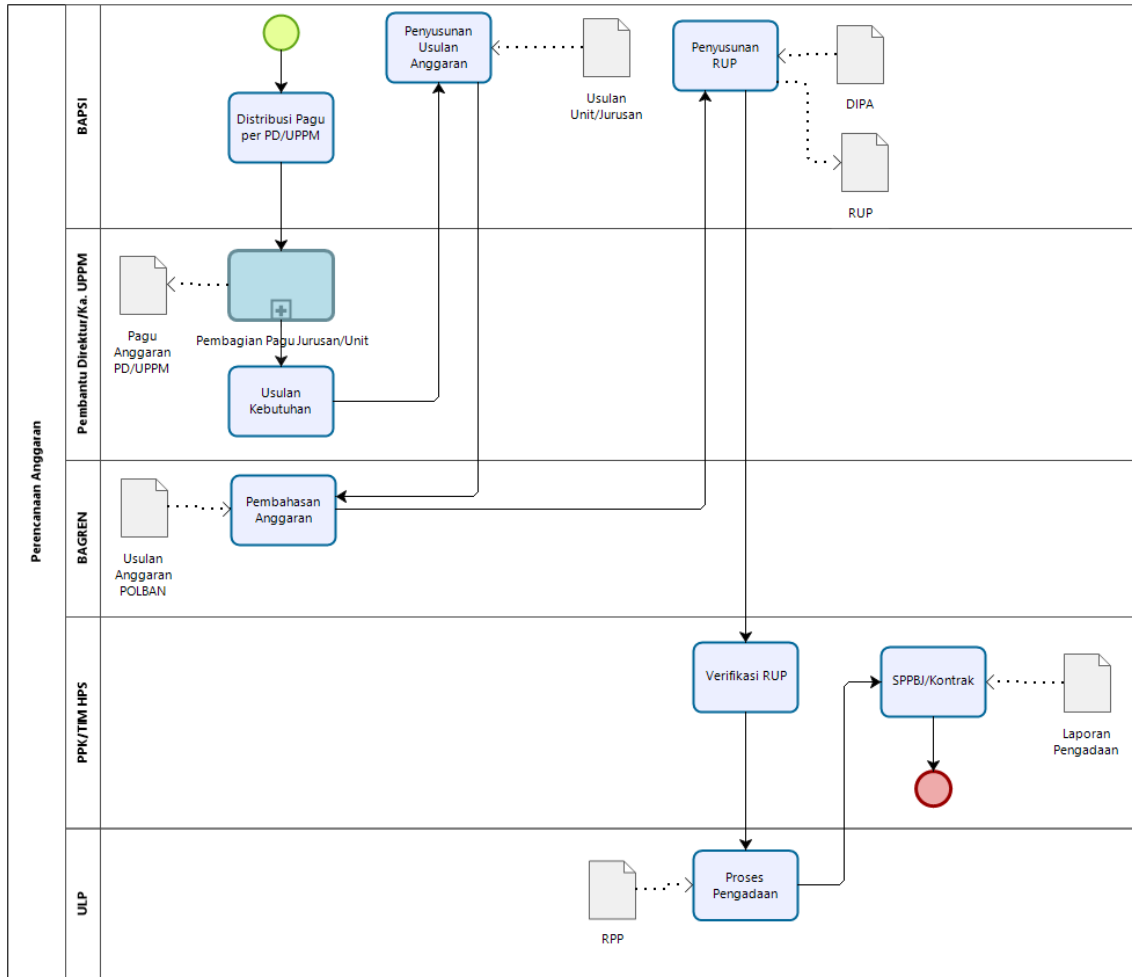

103. PEMBAGIAN PAGU JURUSAN UNIT

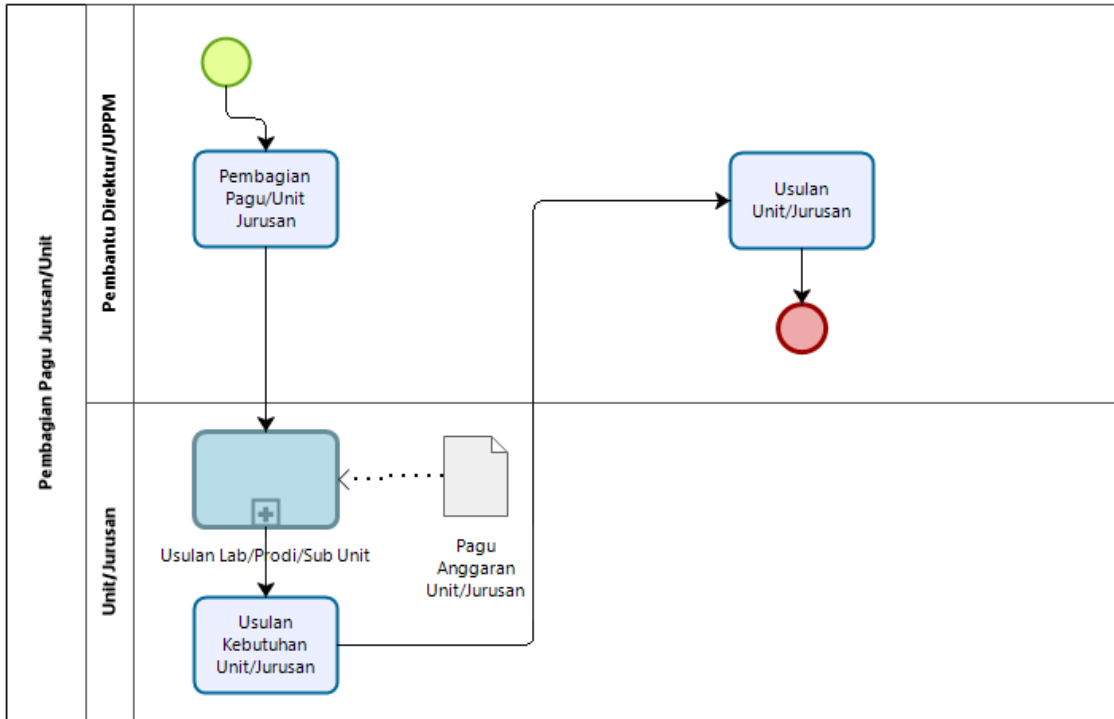

104. USULAN PENGADAAN BARANG/ALAT LAB DARI PRODI/SUB UNIT

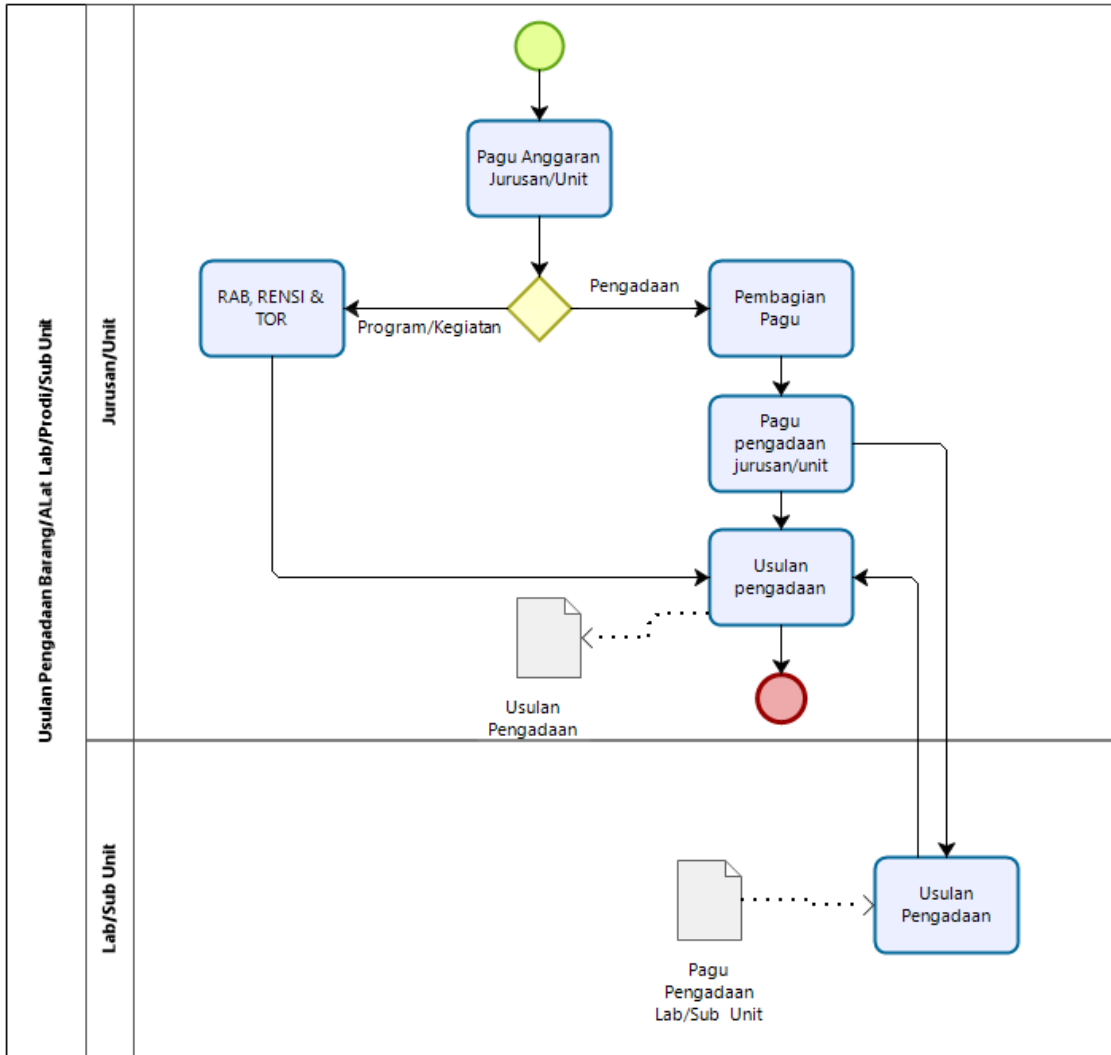

105. PENYUSUNAN RAB KEGIATAN

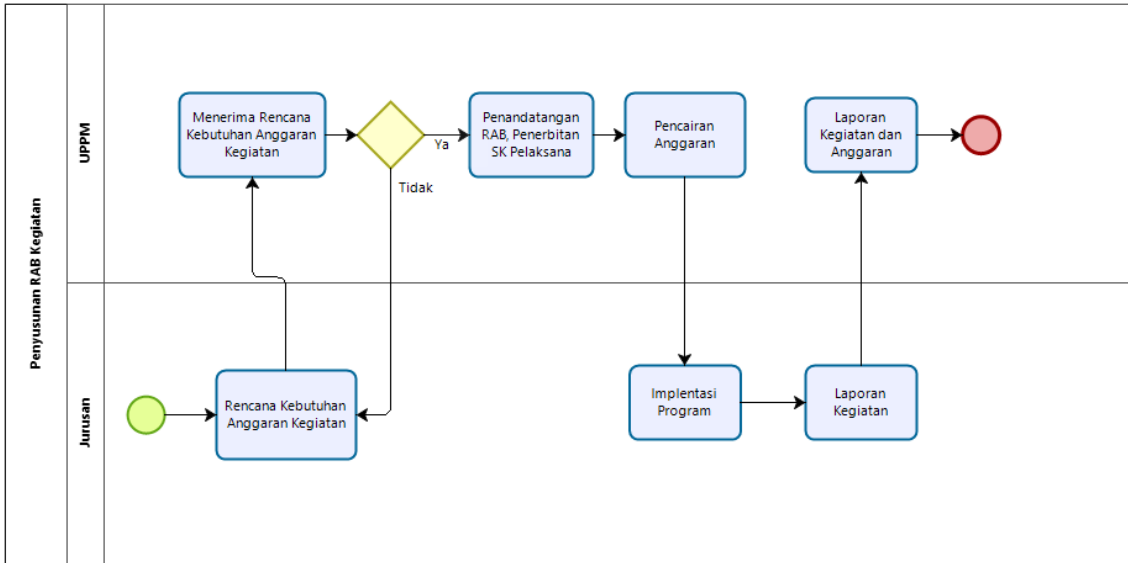

106. MONITORING & REVISI ANGGARAN

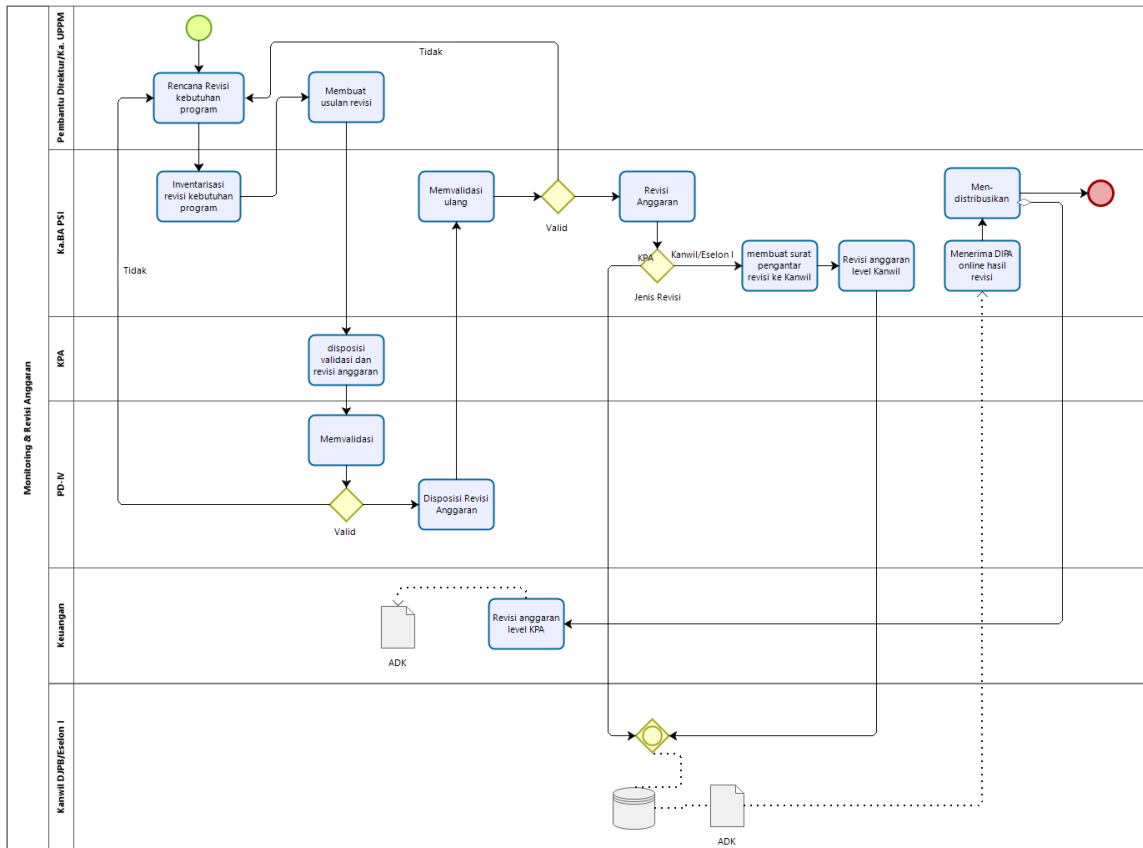

107. LAYANAN ADM KEMAHASISWAAN



108. KELEMBAGAAN DAN PEMBINAAN

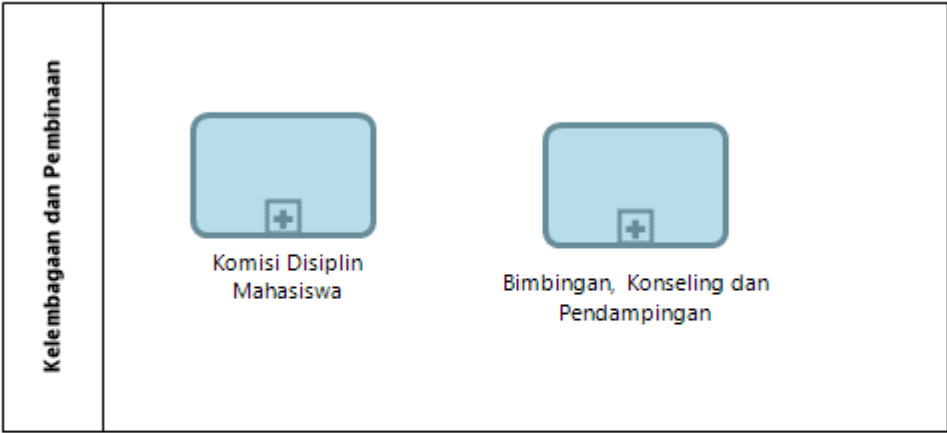

109. KOMISI DISIPLIN MAHASISWA

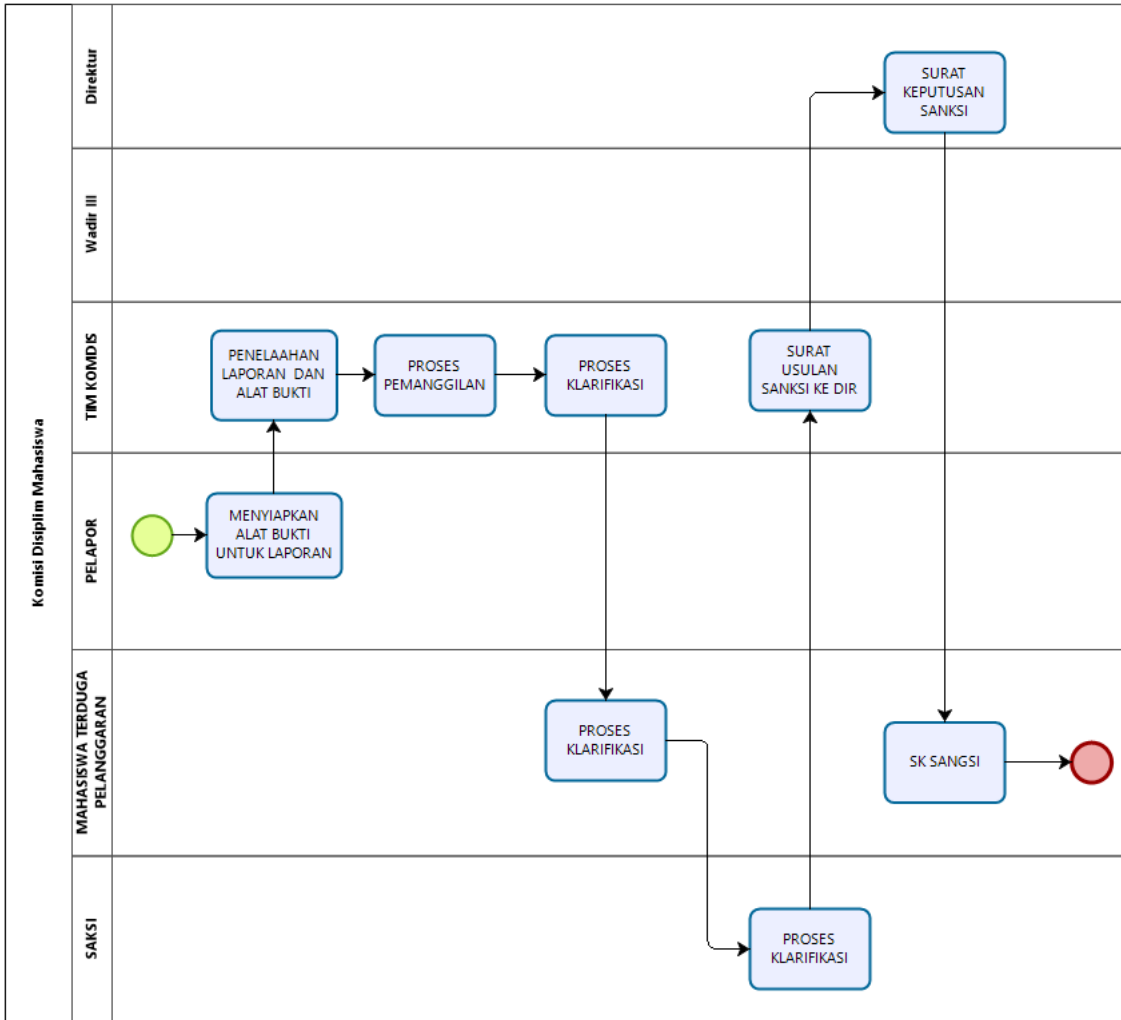

110. BELA NEGARA

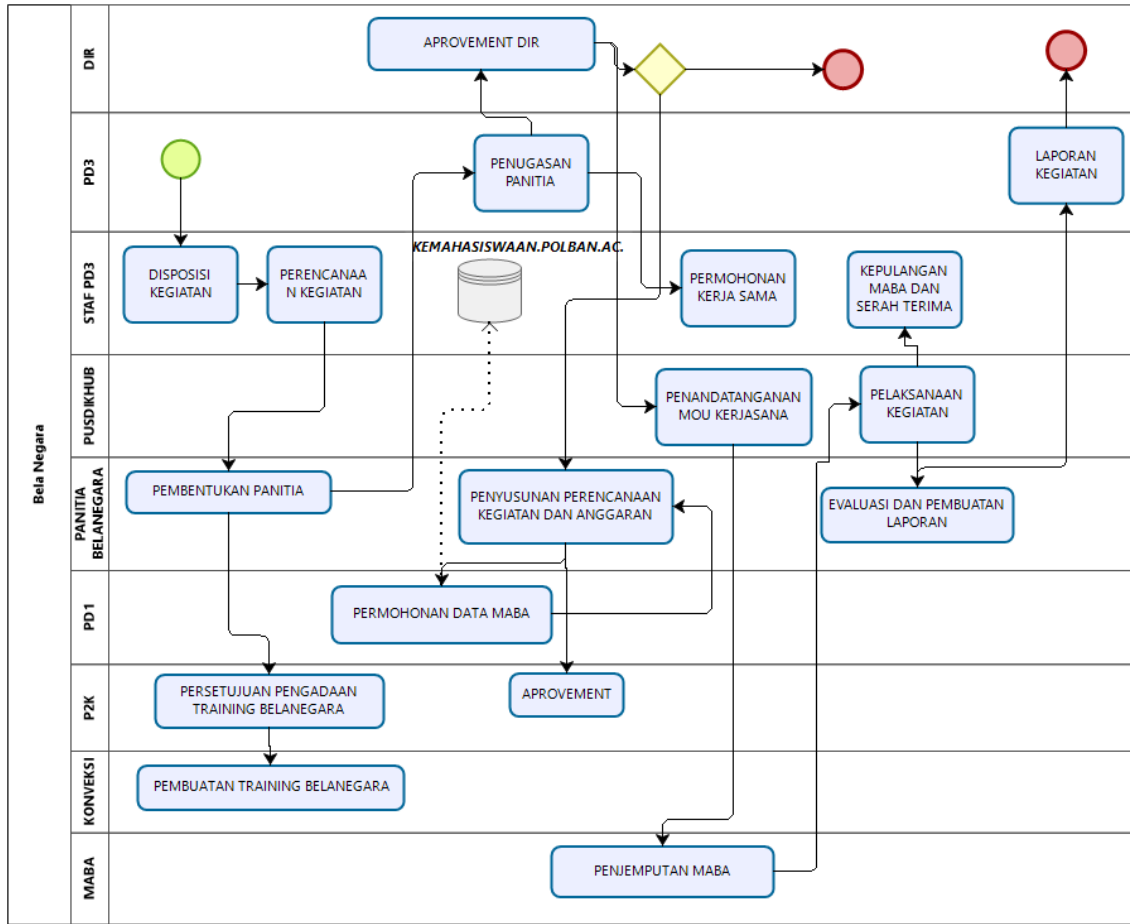

111. KEGIATAN ORMAWA

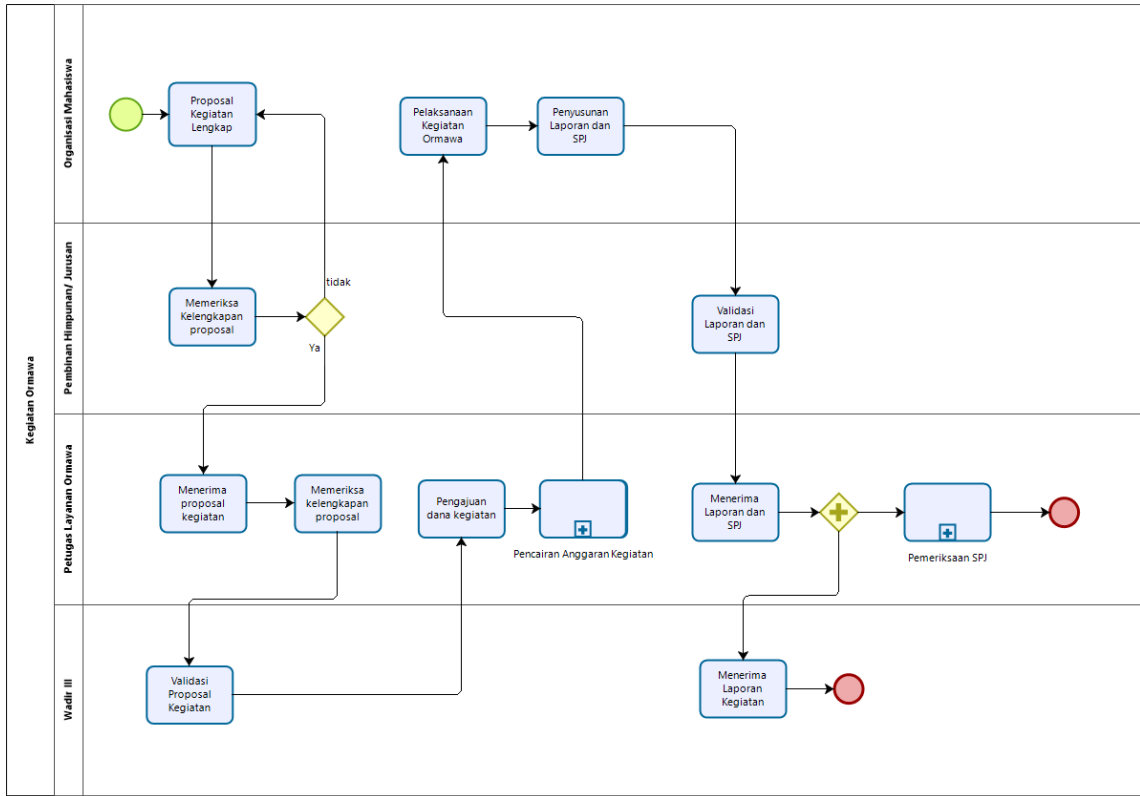

112. KEWIRAUSAHAAN

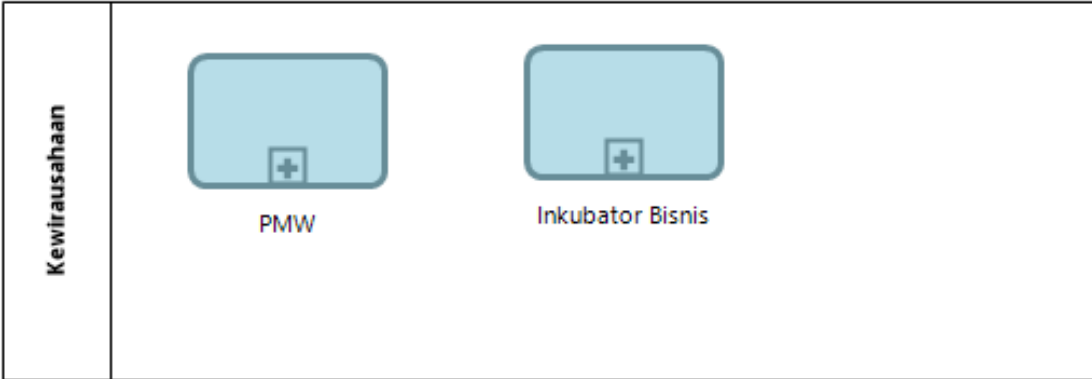

113. KOMPETISI

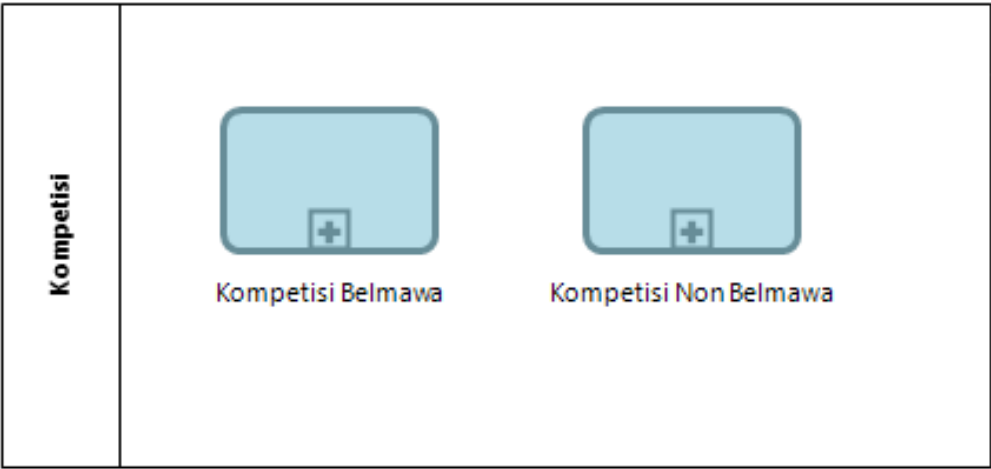

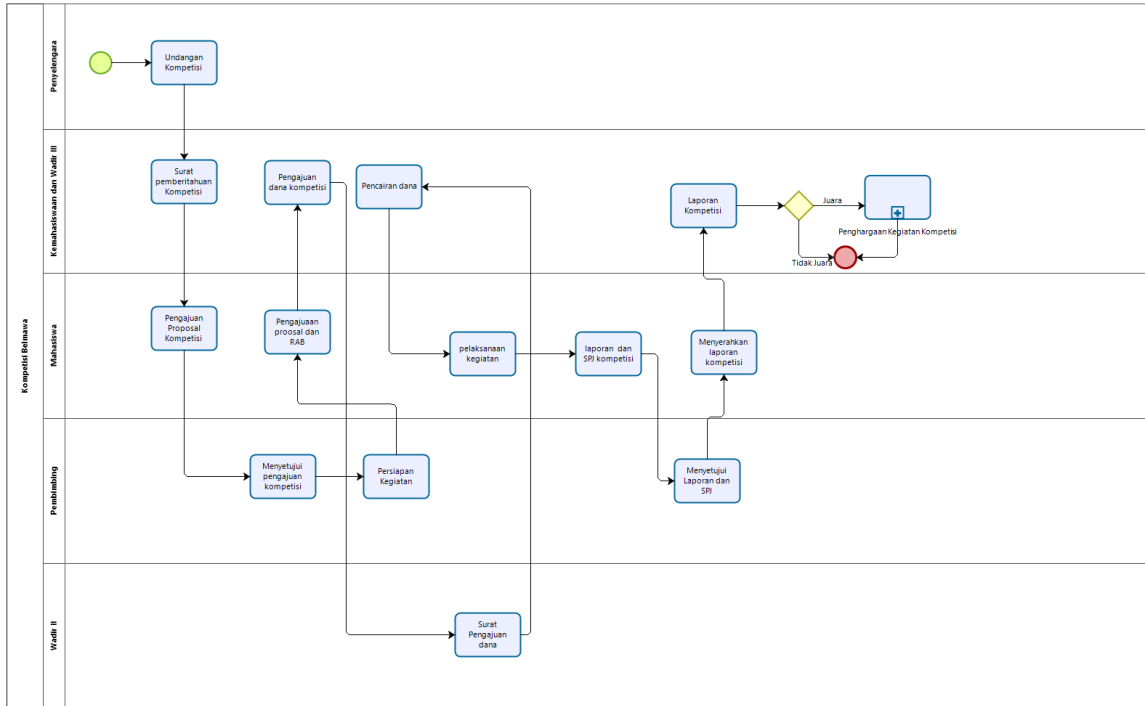

114. KOMPETISI BELMAWA

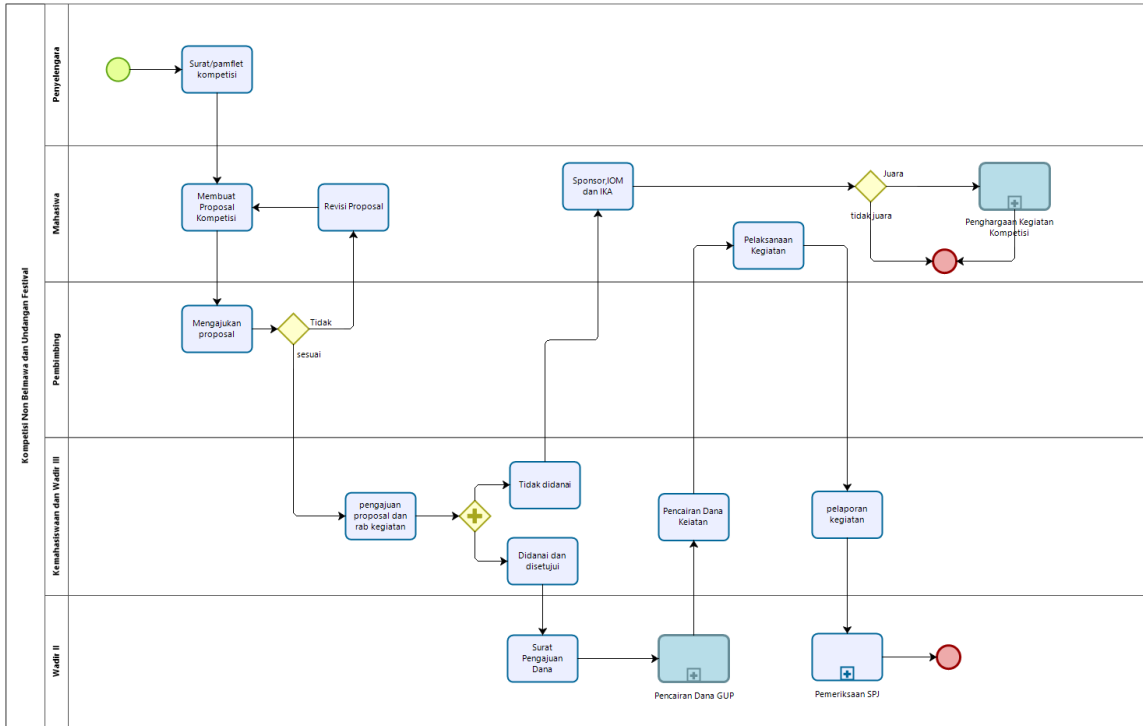

115. KOMPETISI NON BELMAWA DAN UNDANGAN FESTIVAL



116. LAYANAN ALUMNI

Layanan Alumni	 Tracer Study	 Job Placement and Assessment Center
-----------------------	---	--



117. JOB PLACEMENT AND ASSESSMENT CENTRAL

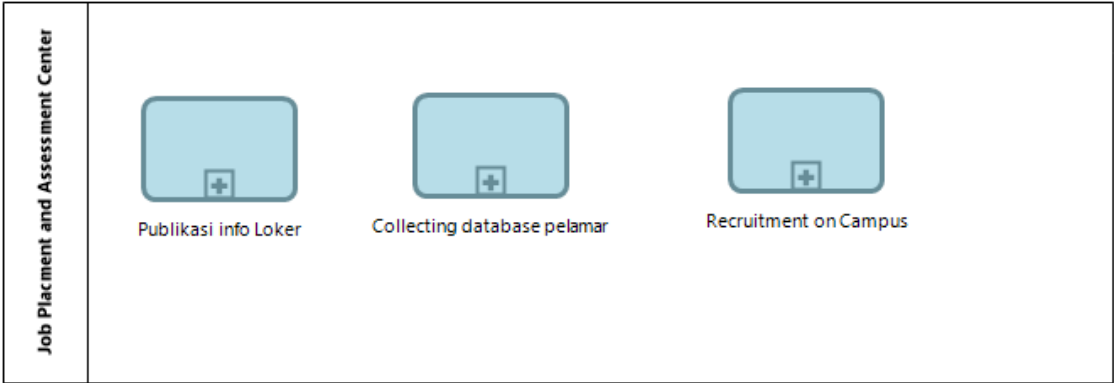

118. COLLECTING DATABASE PELAMAR

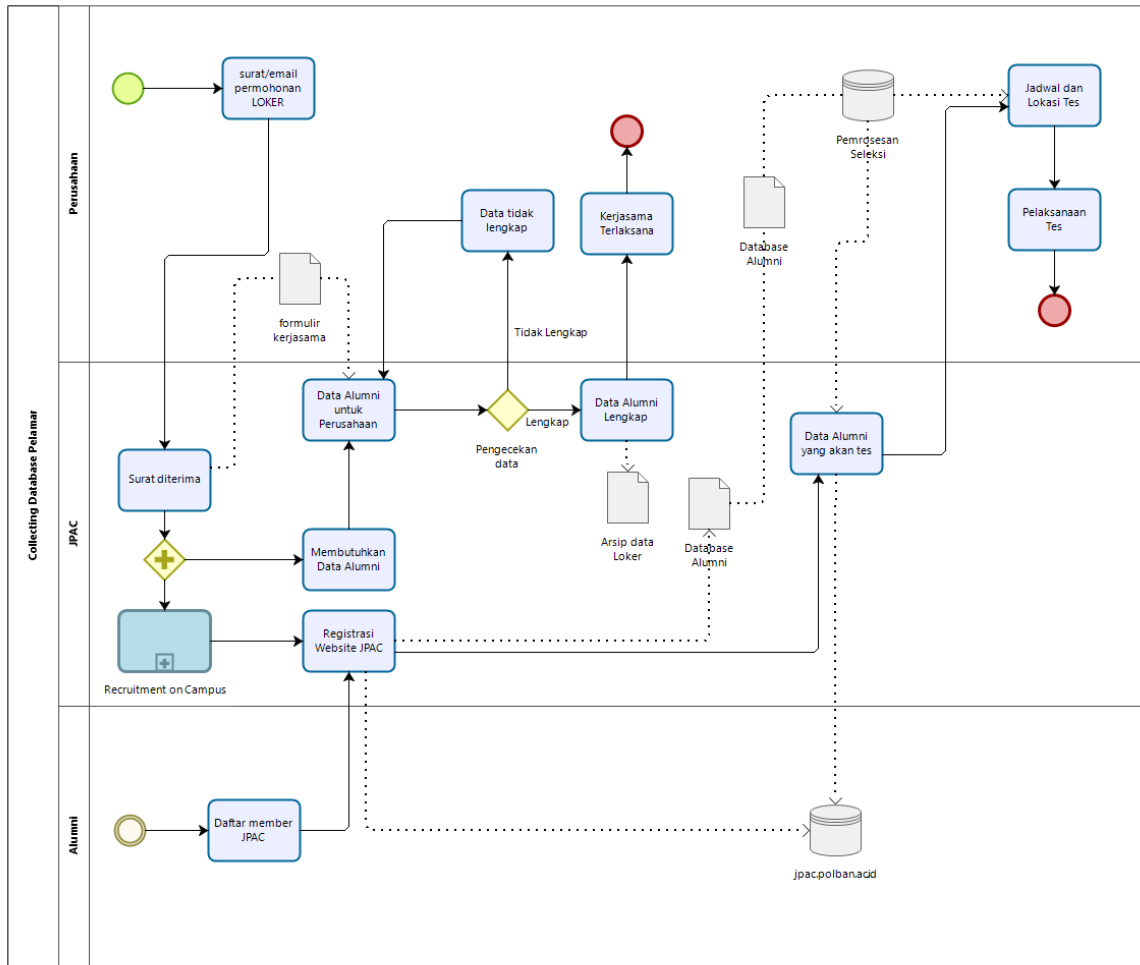

119. RECRUITMENT ON CAMPUS.

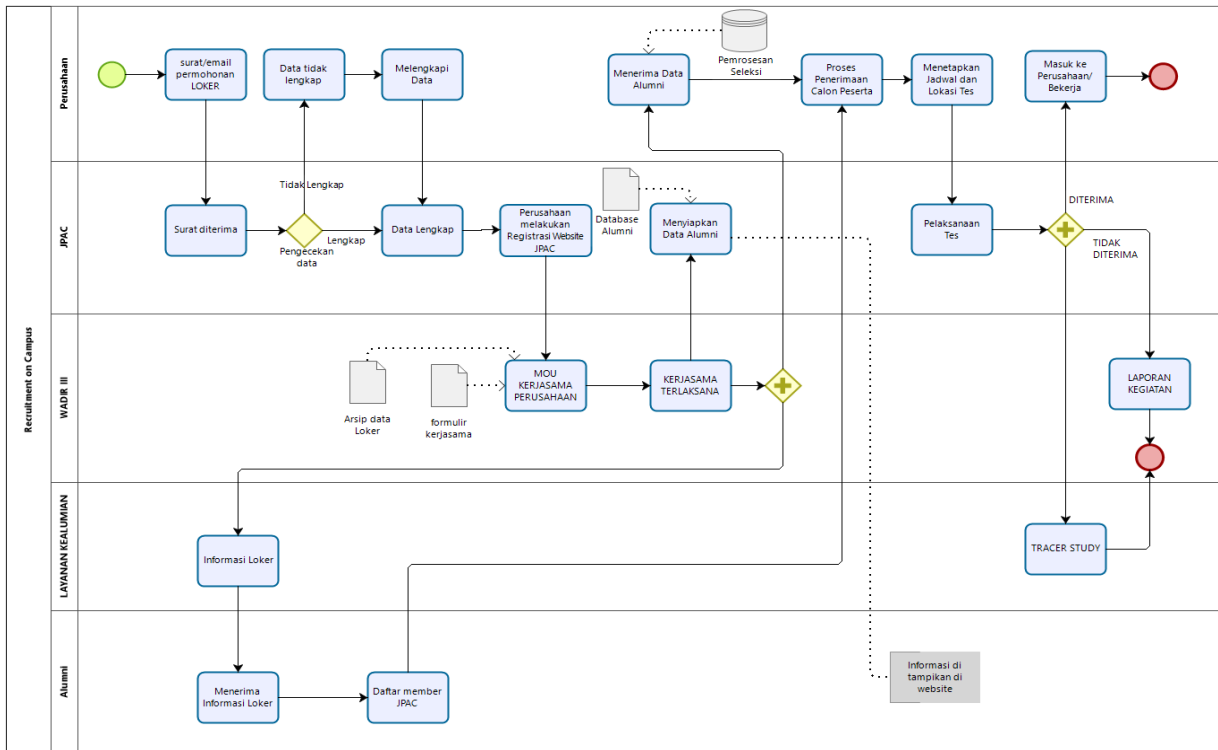

120. TRACER STUDY

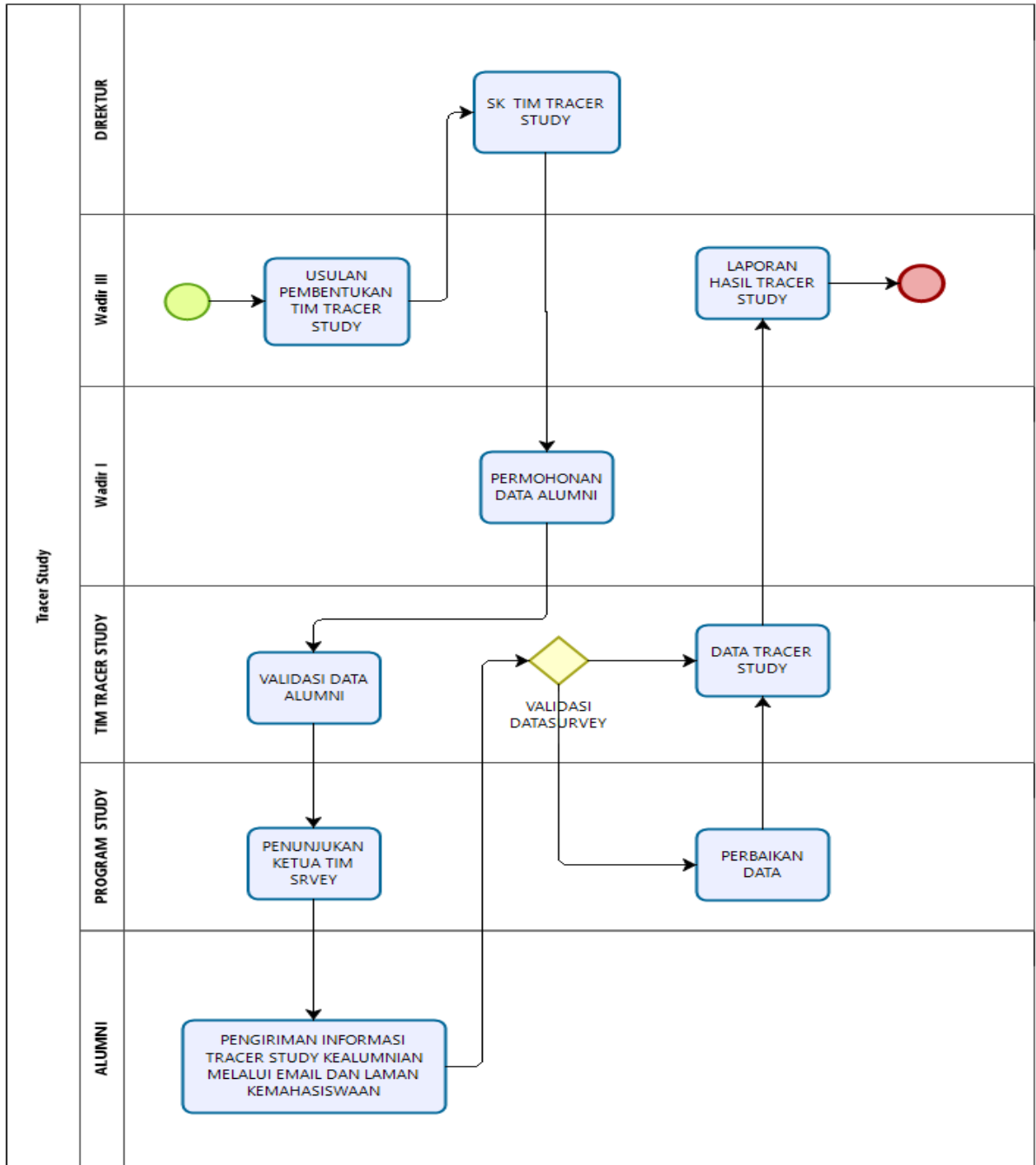

121. LAYANAN KESEJAHTERAAN MAHASISWA



122. LAYANAN BEASISWA

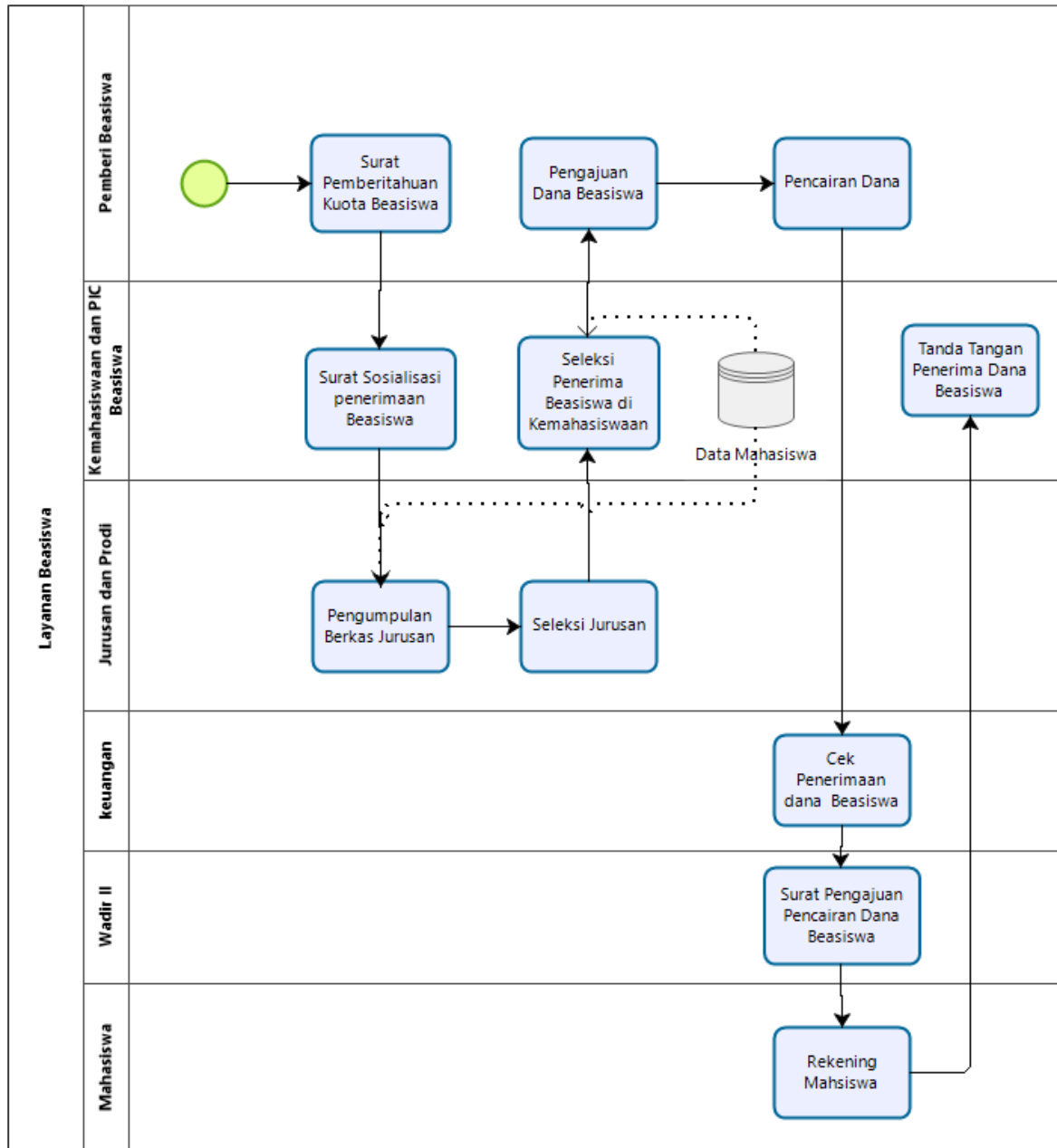

123. LAYANAN ASURANSI

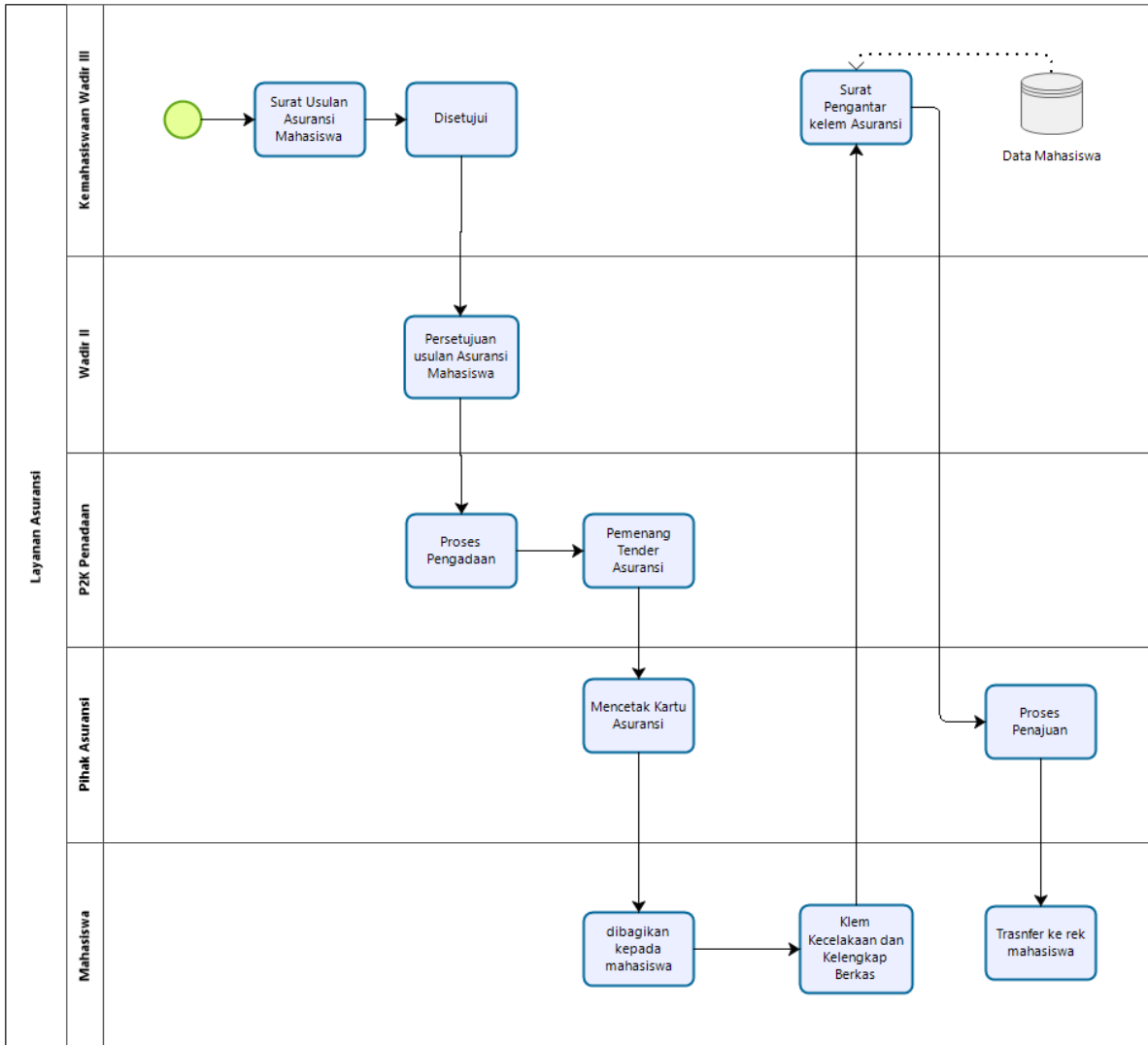

124. BANTUAN IOM UNTUK SPP DAN TUGAS AKHIR

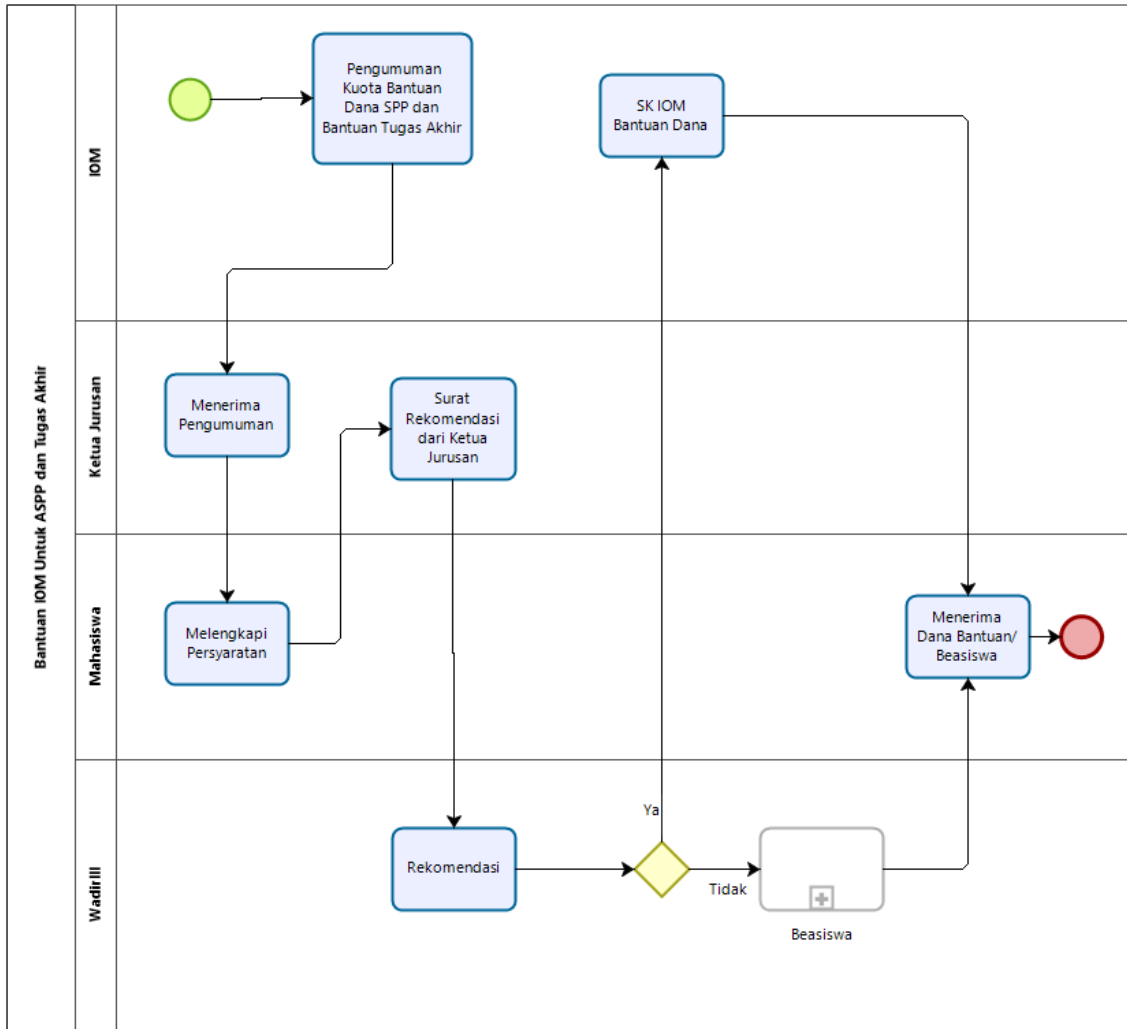

125. BANTUAN IOM UNTUK PENGEMBANGAN MINAT DAN BAKAT

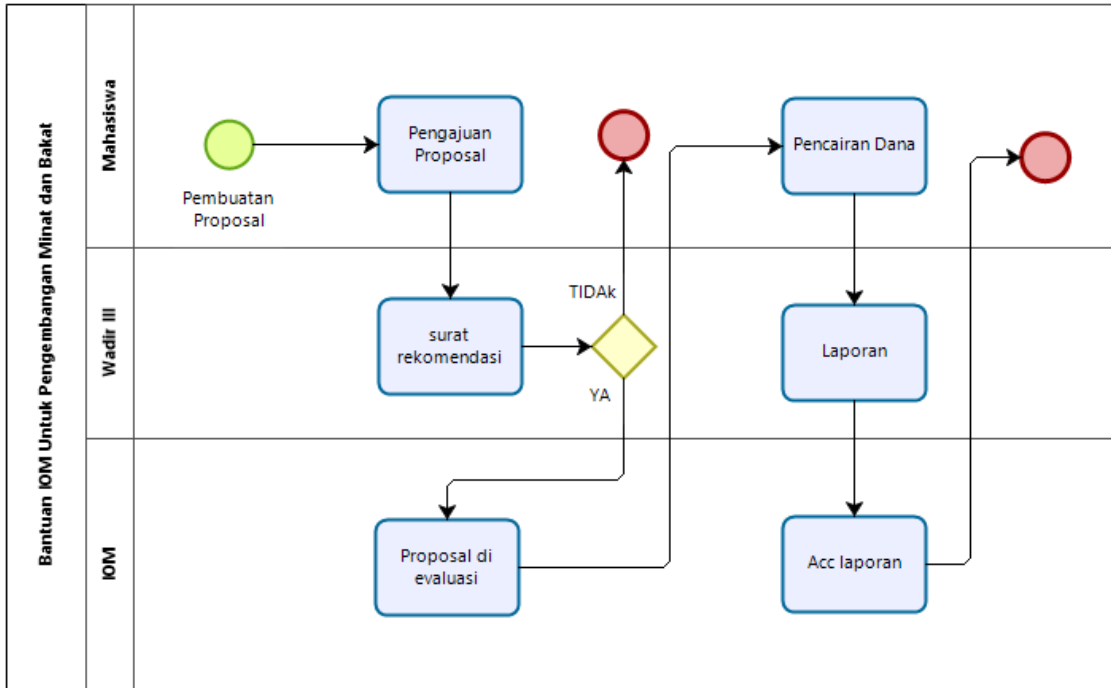

126. BANTUAN PROGRAM BIDIK MISI

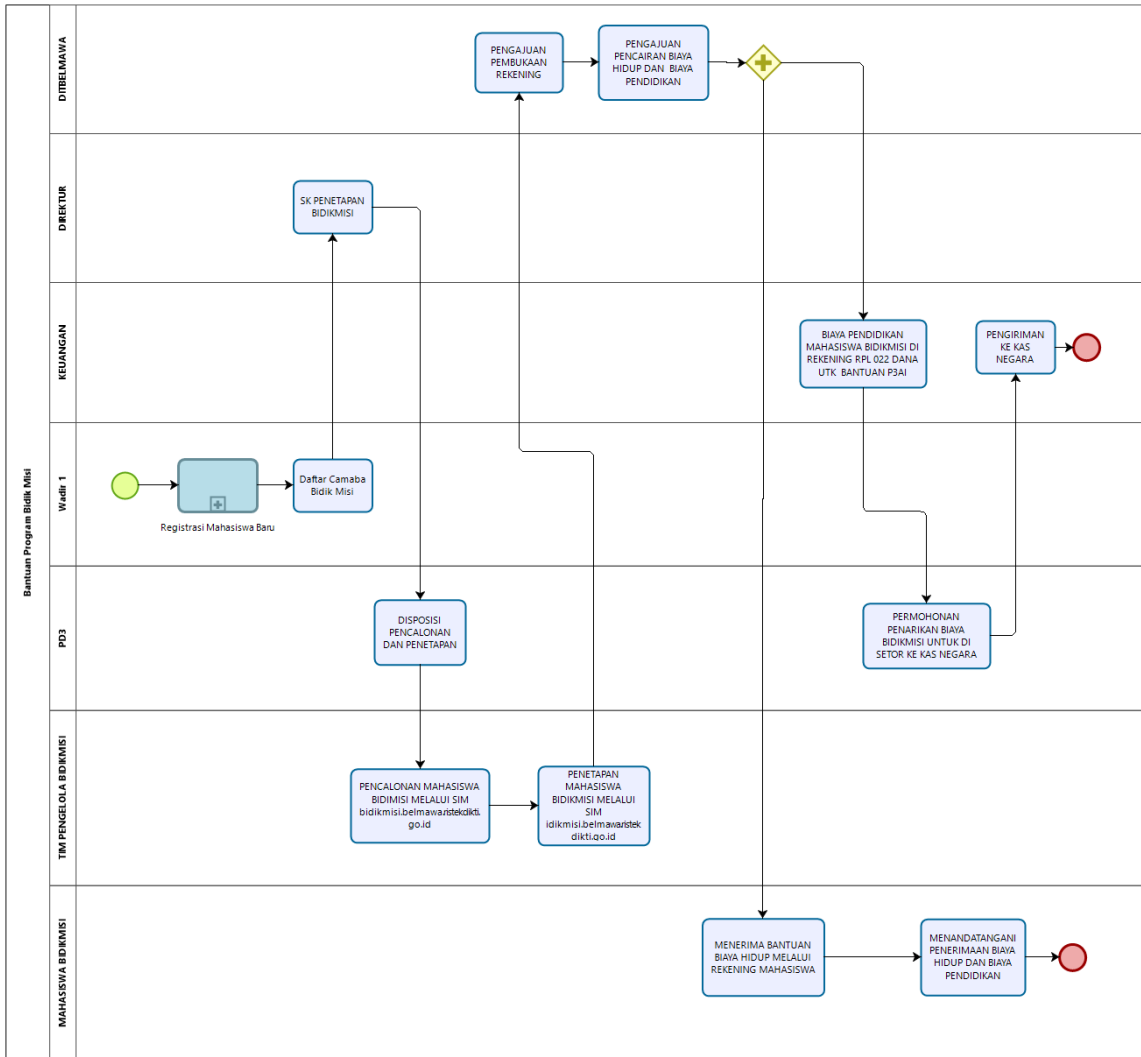

127. INKUBATOR BISNIS POLBAN

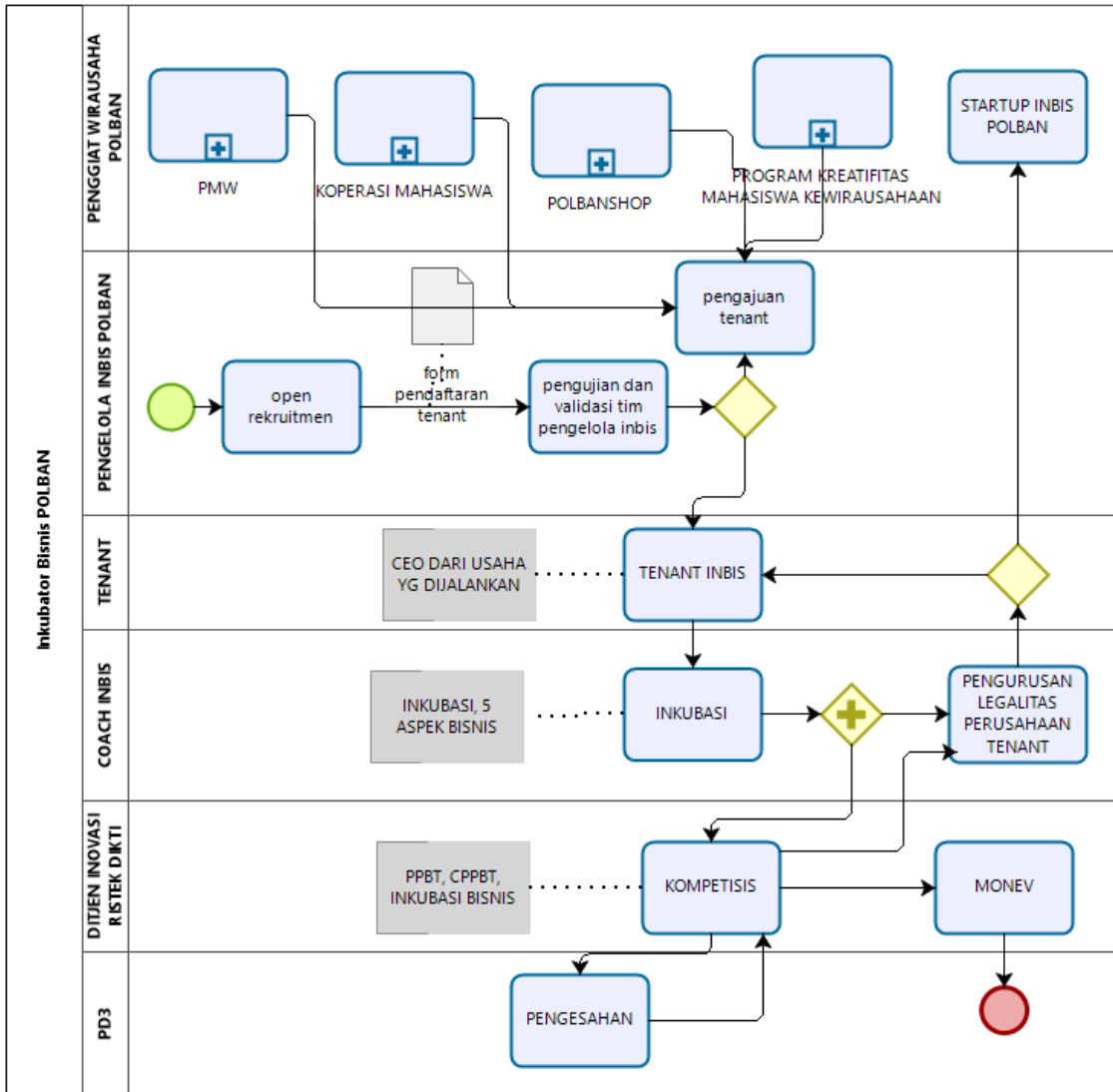

128. PENGHARGAAN KEGIATAN KOMPETISI

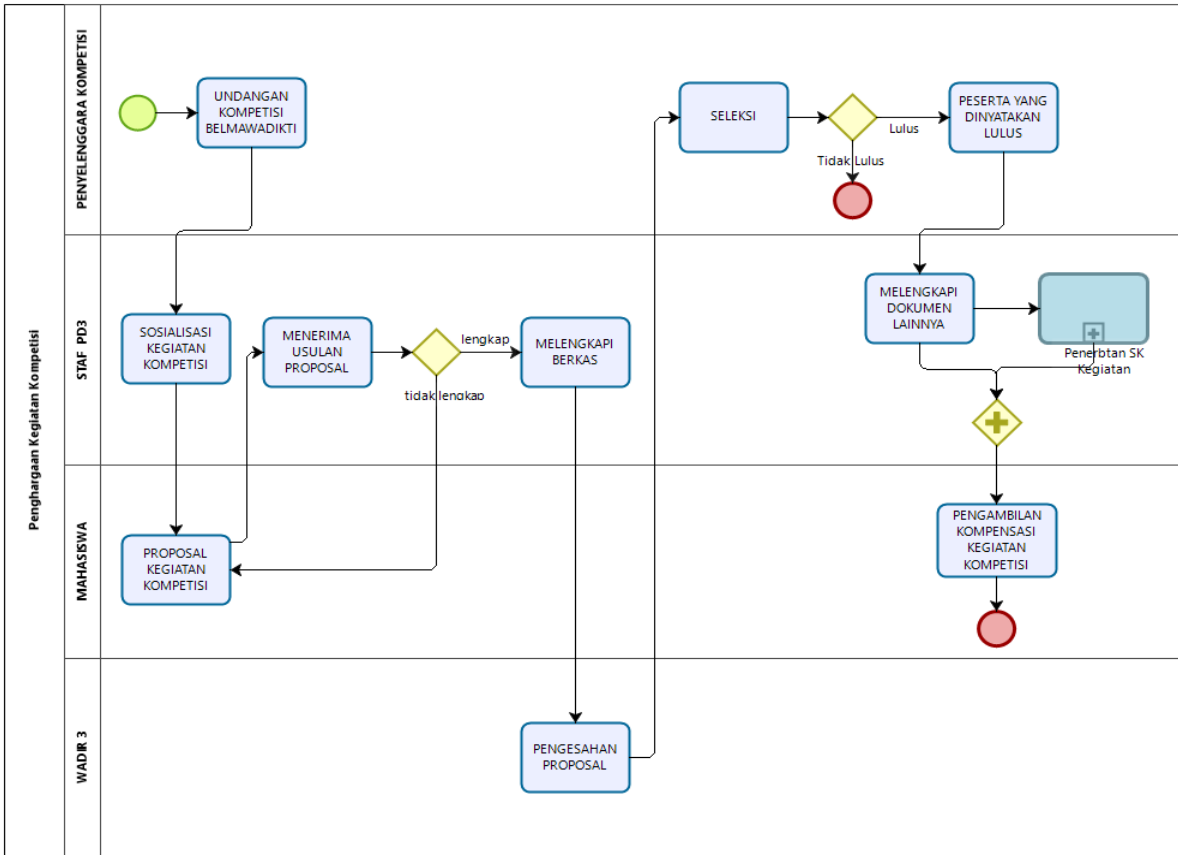

Powered by **bizagi** Modeler

129. PROGRAM PENGENALAN KAMPUS



130. PENINGKATAN KARAKTER DAN SOFT SKILL

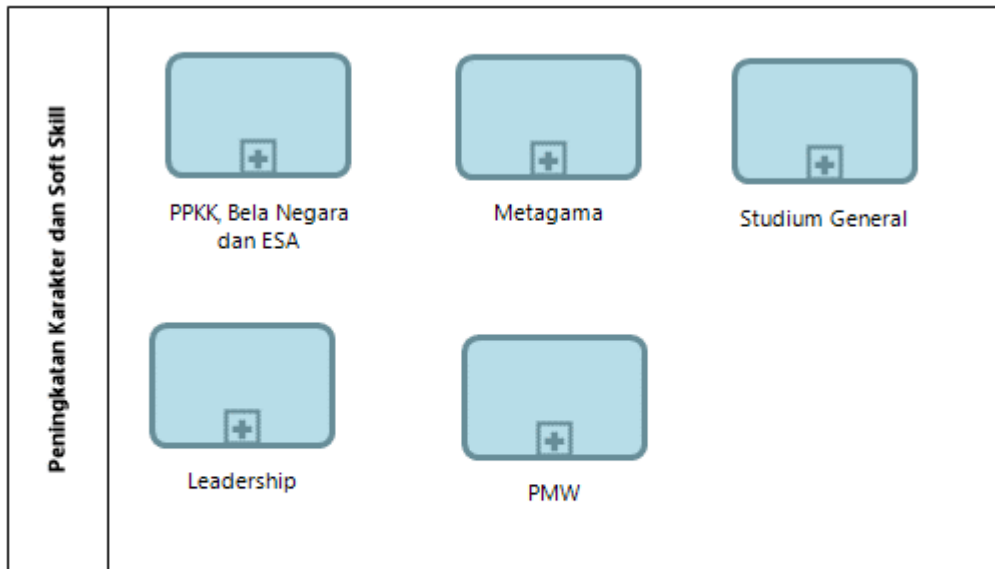

Powered by
bizagi
Modeler

131. PPKK

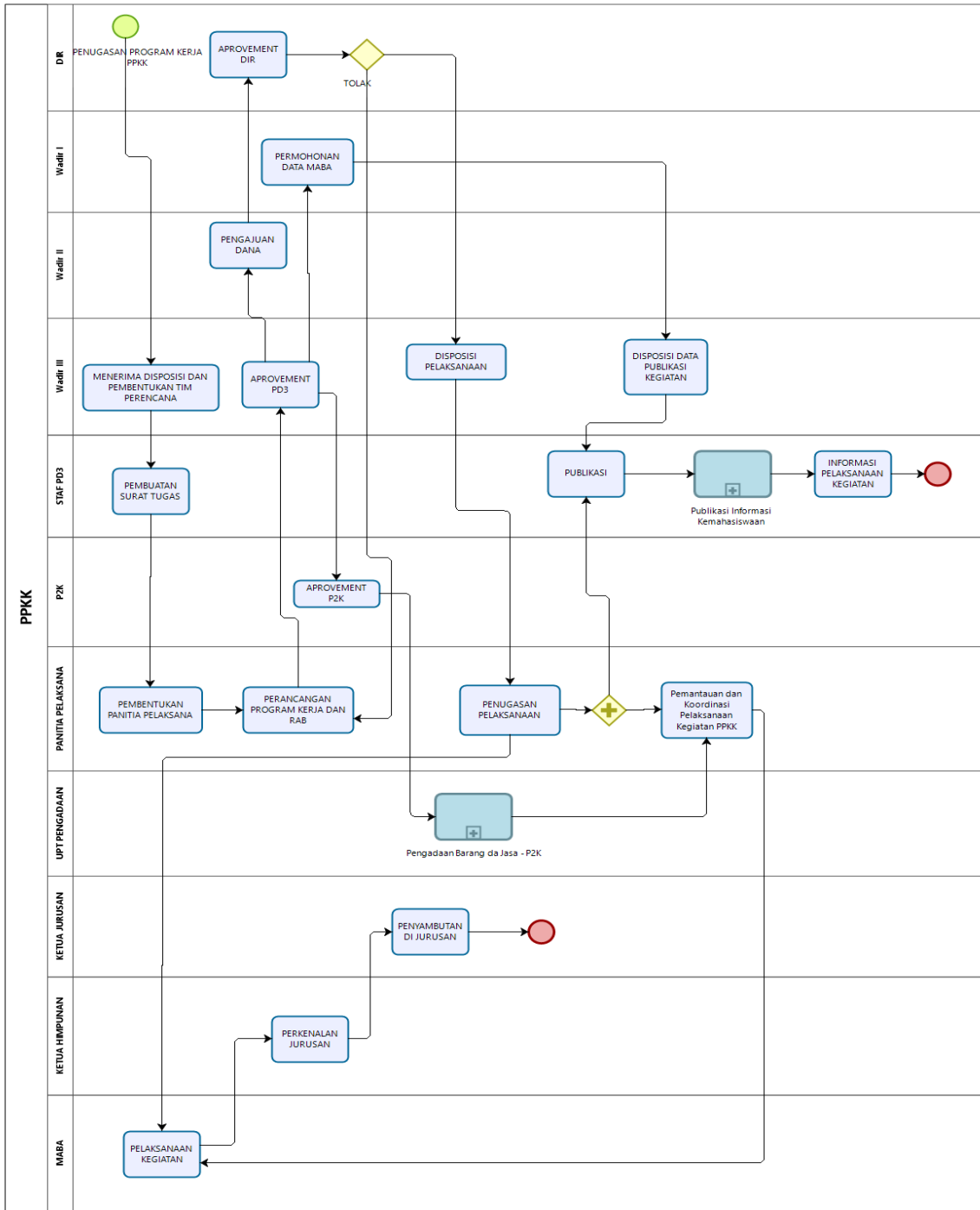

132. METAGAMA

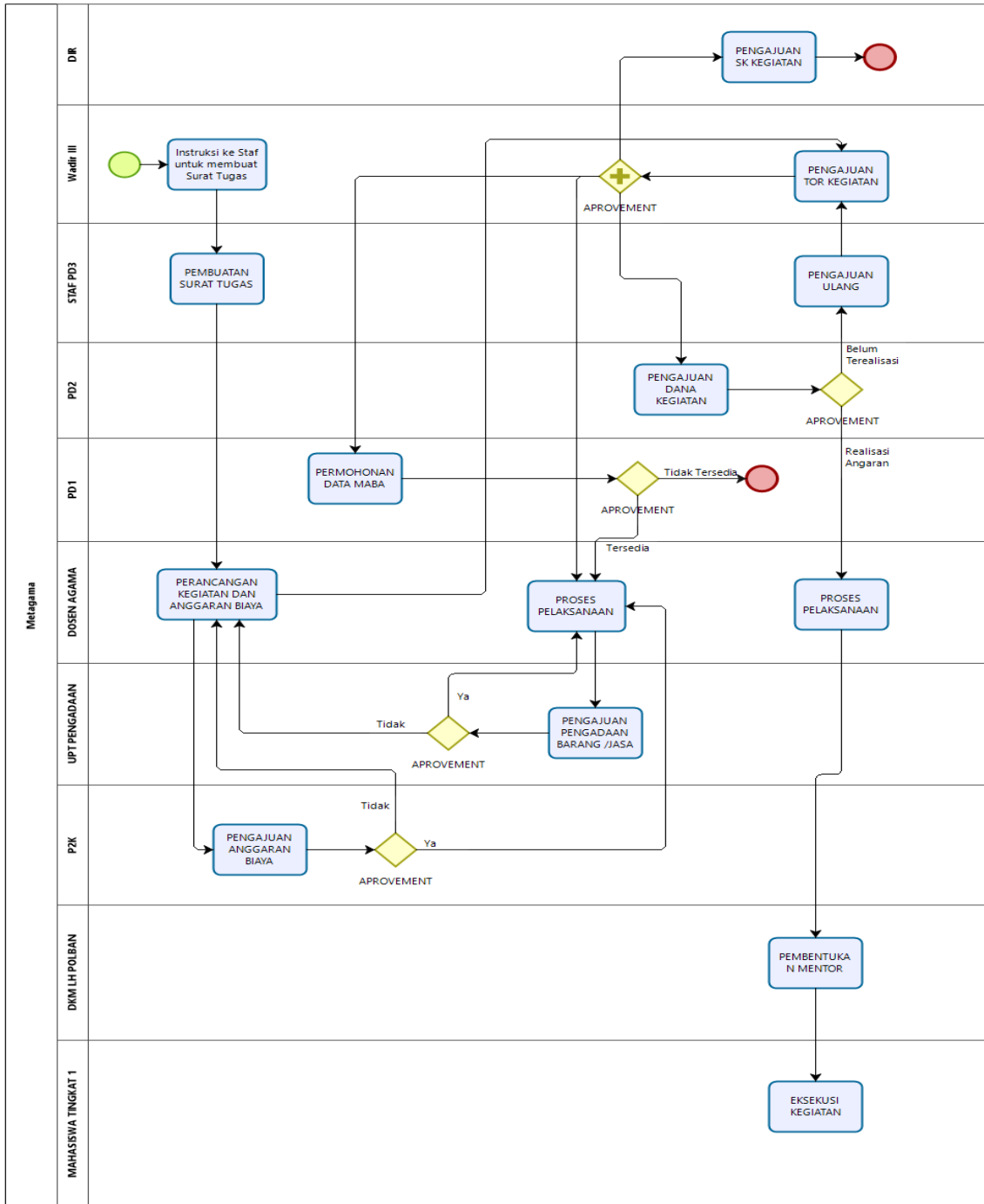

133. STUDIUM GENERAL

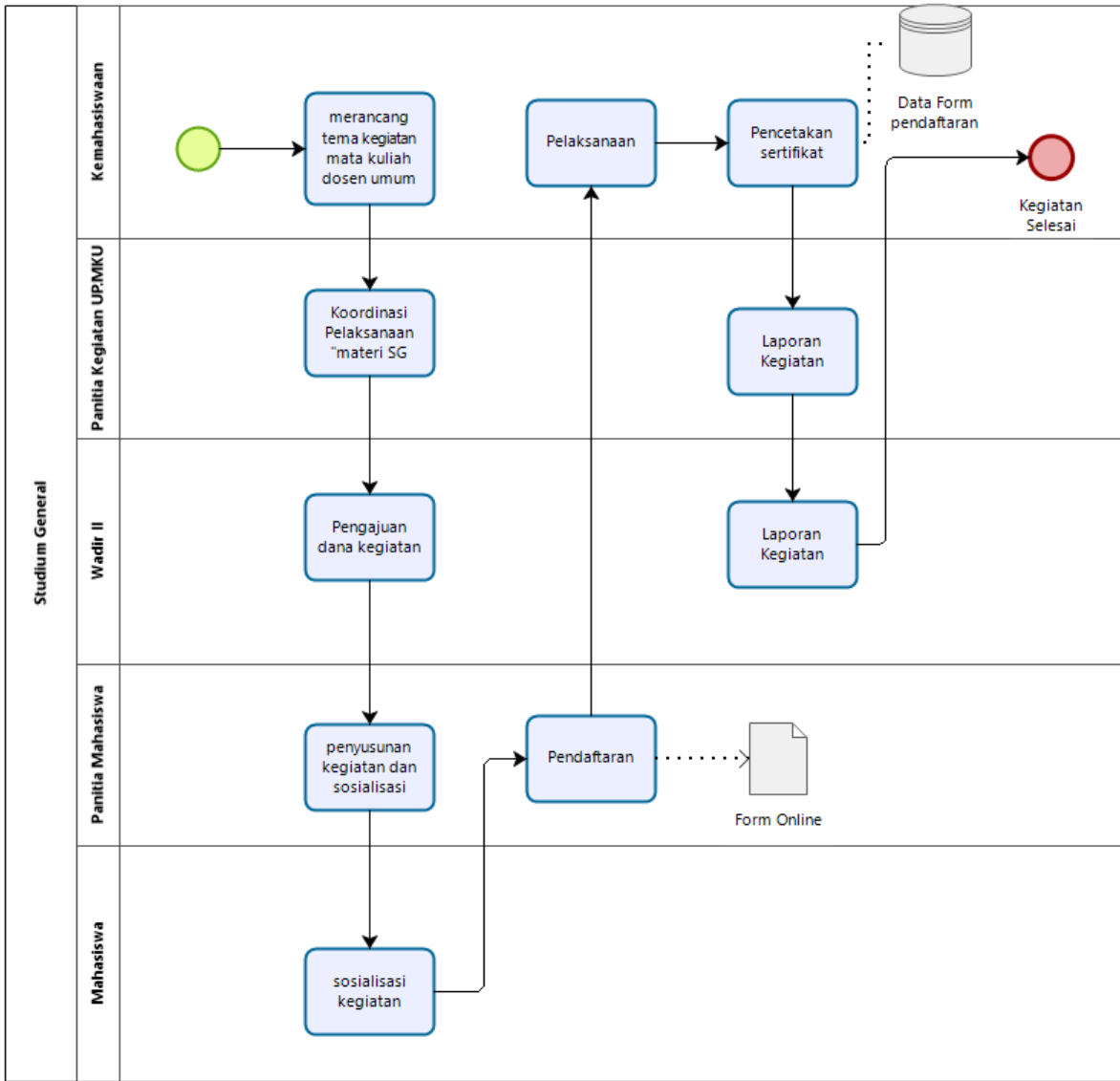

134. LEADERSHIP

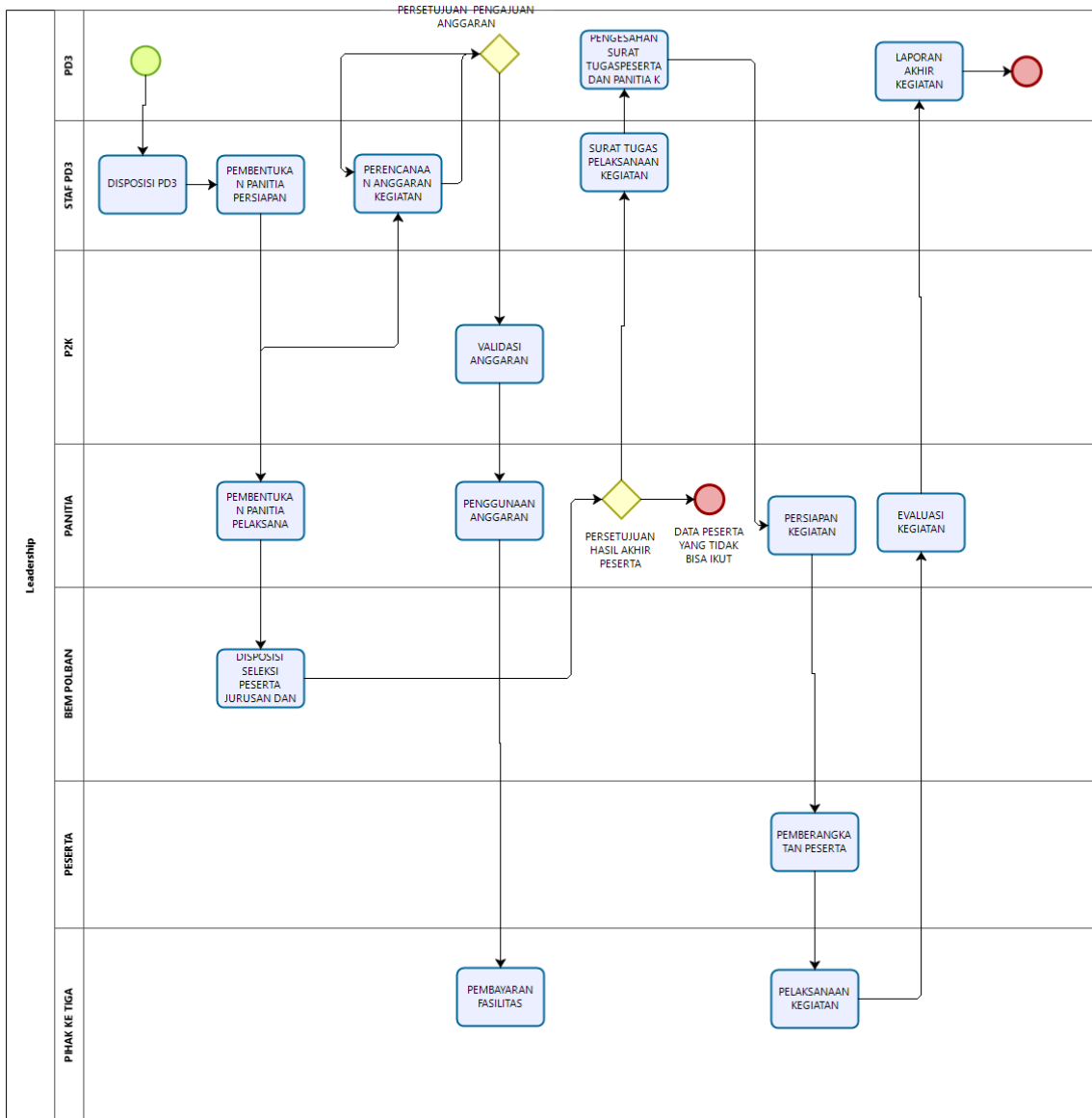

135. PMW

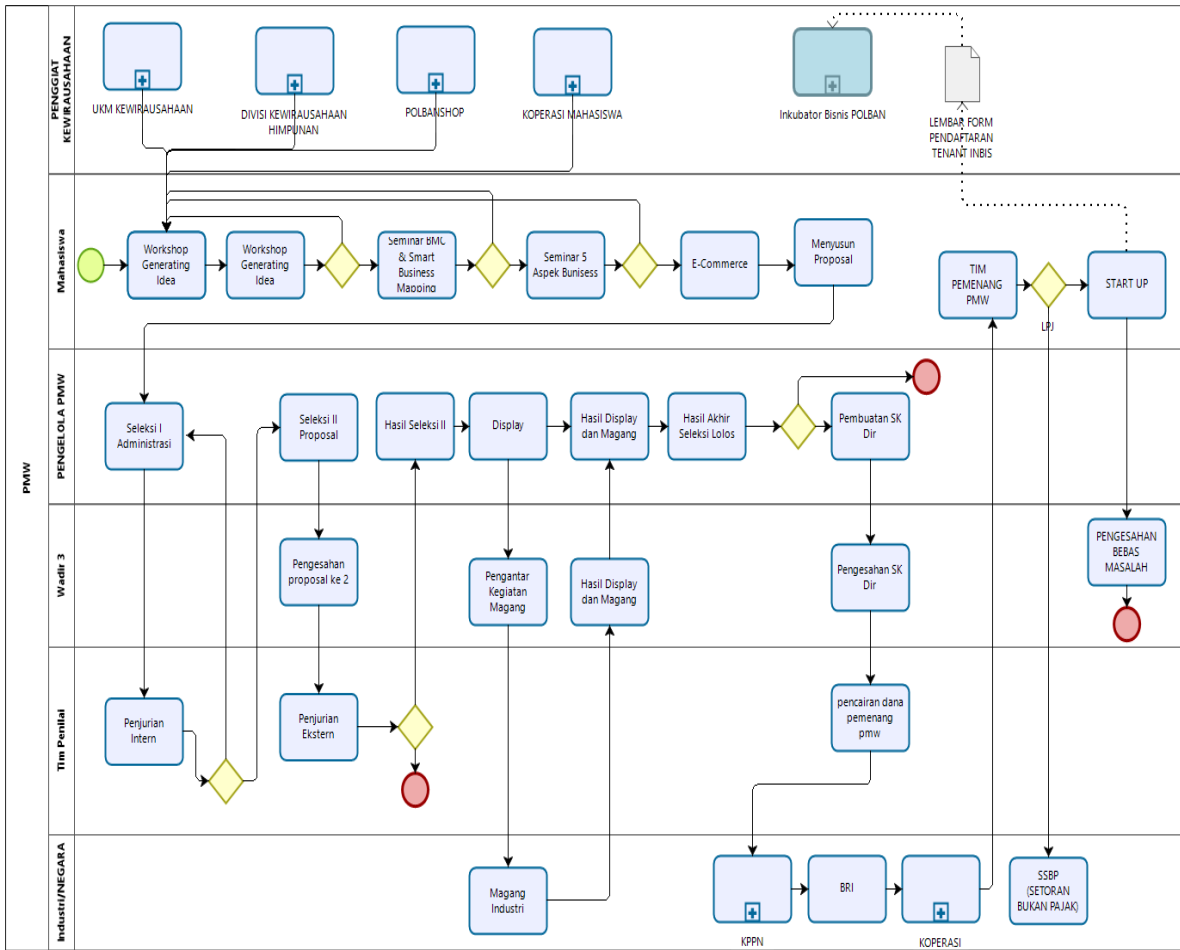

136. BIMBINGAN, KOSELING DAN PENDAMPINGAN

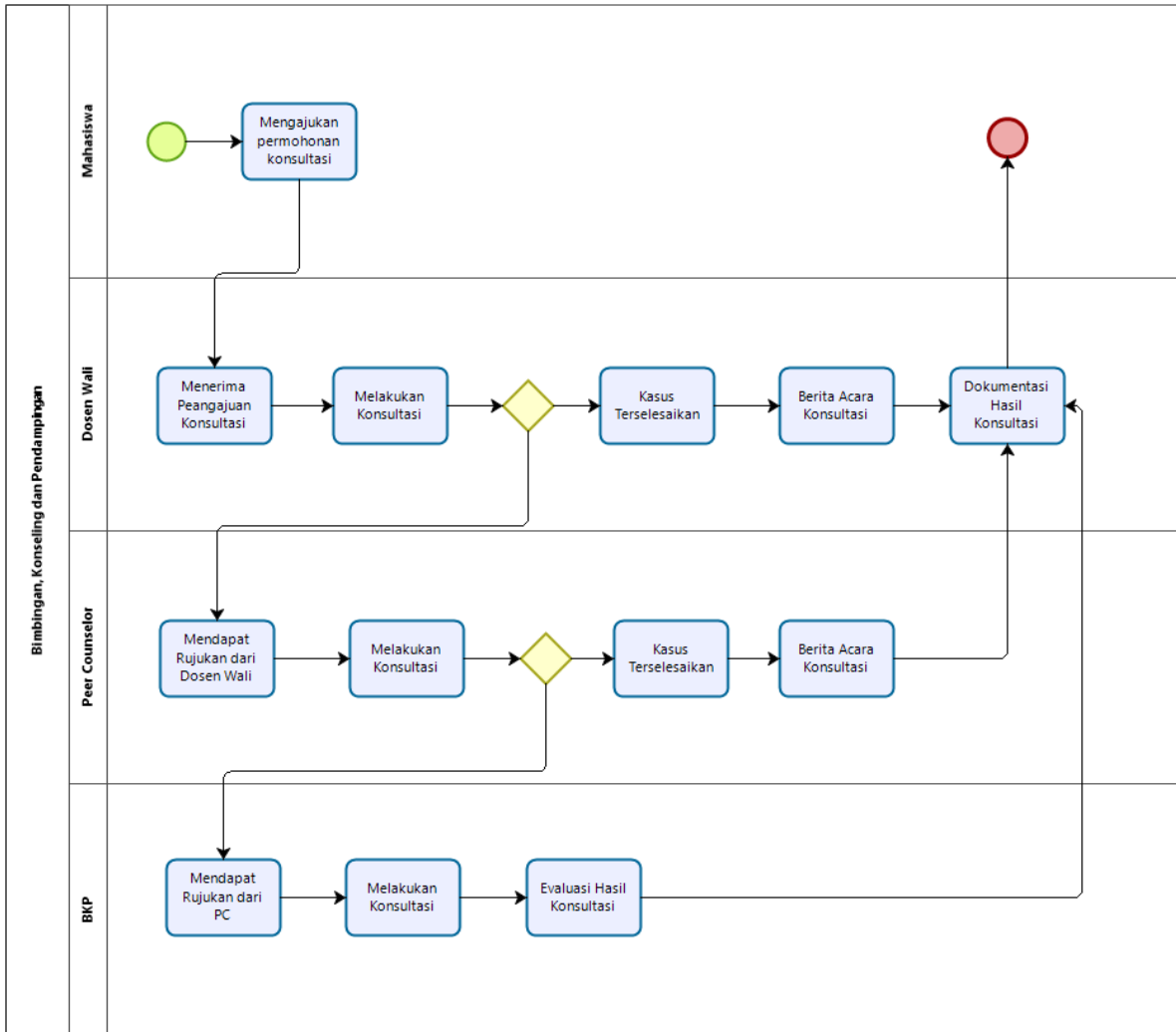

137. PEMBINAAN MINAT & BAKAT

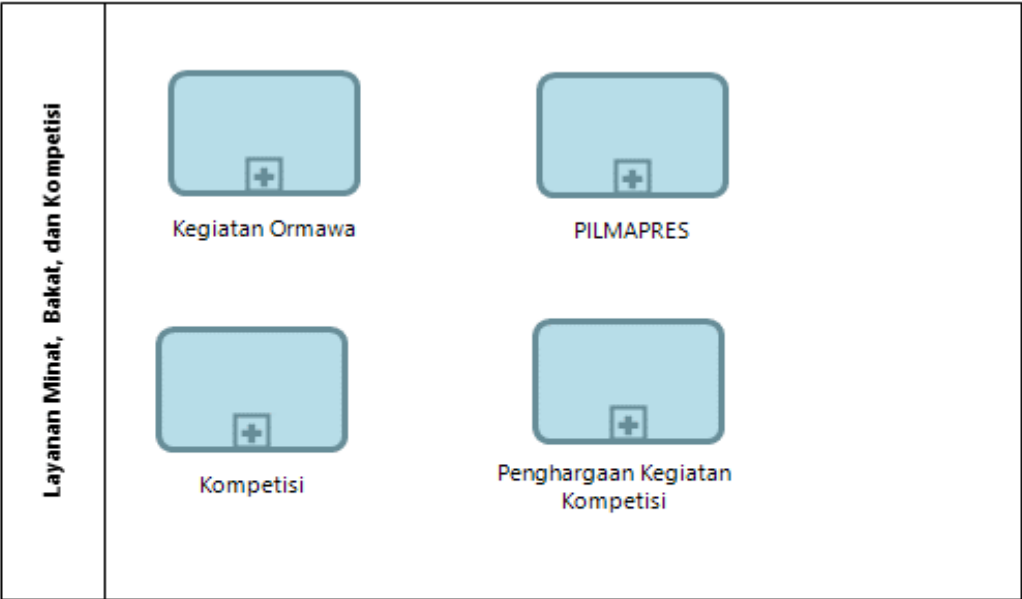

138. PKM KERJASAMA

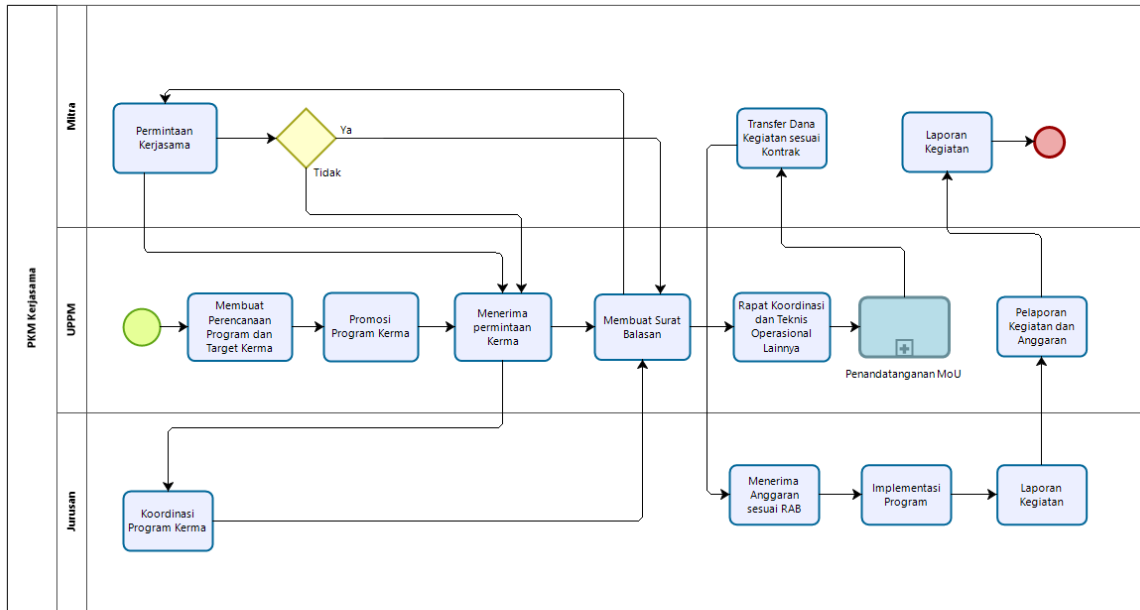

Powered by bizagi Modeler

139. PILMAPRES

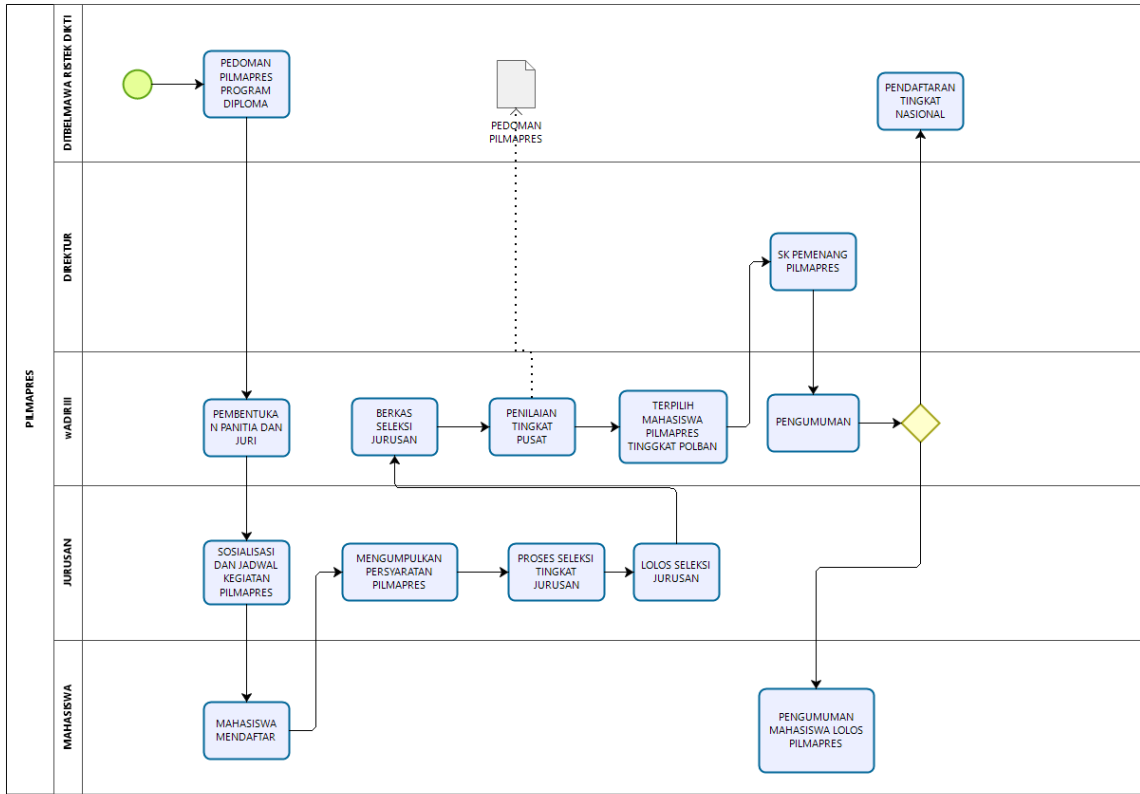

Powered by
bizagi
Modeler

140. KERJASAMA INTERNASIONAL MELALUI MOU

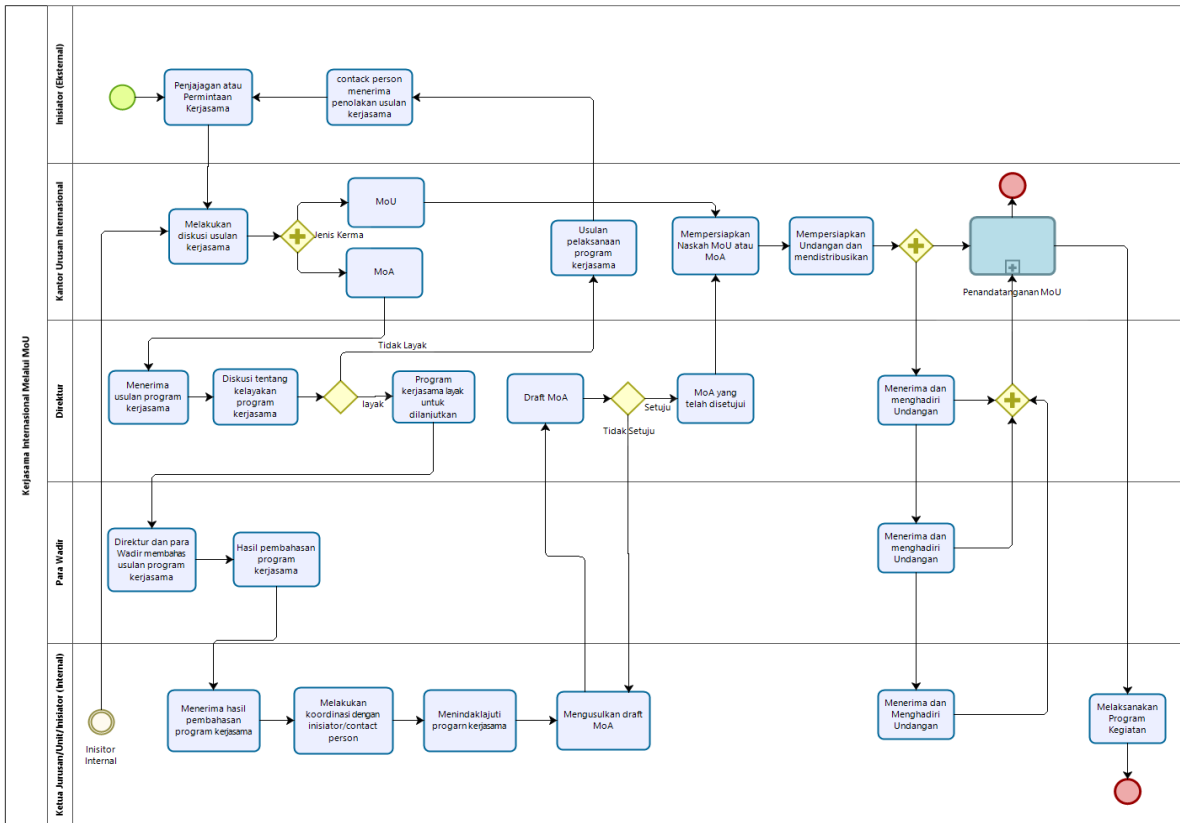

141. PUBLIKASI INFORMASI KEMAHASISWAAN

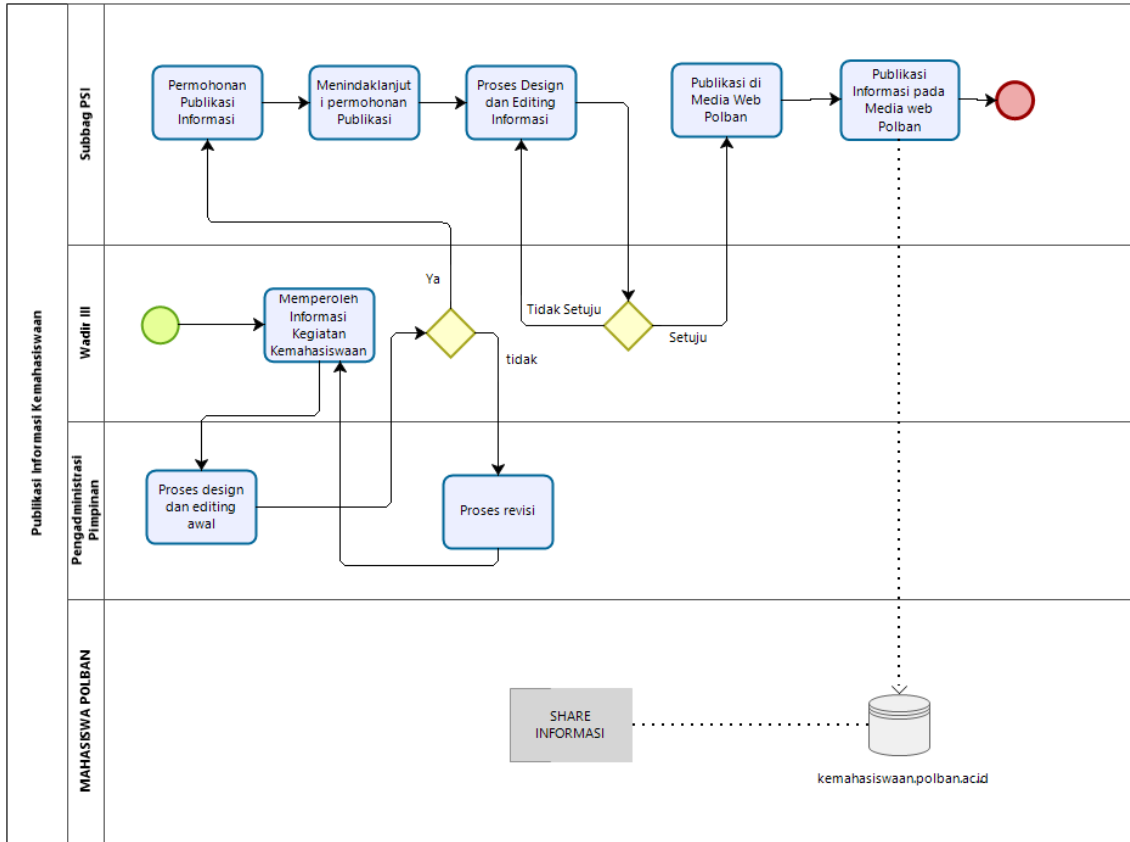

142. PUBLIKASI INFO LOKER.

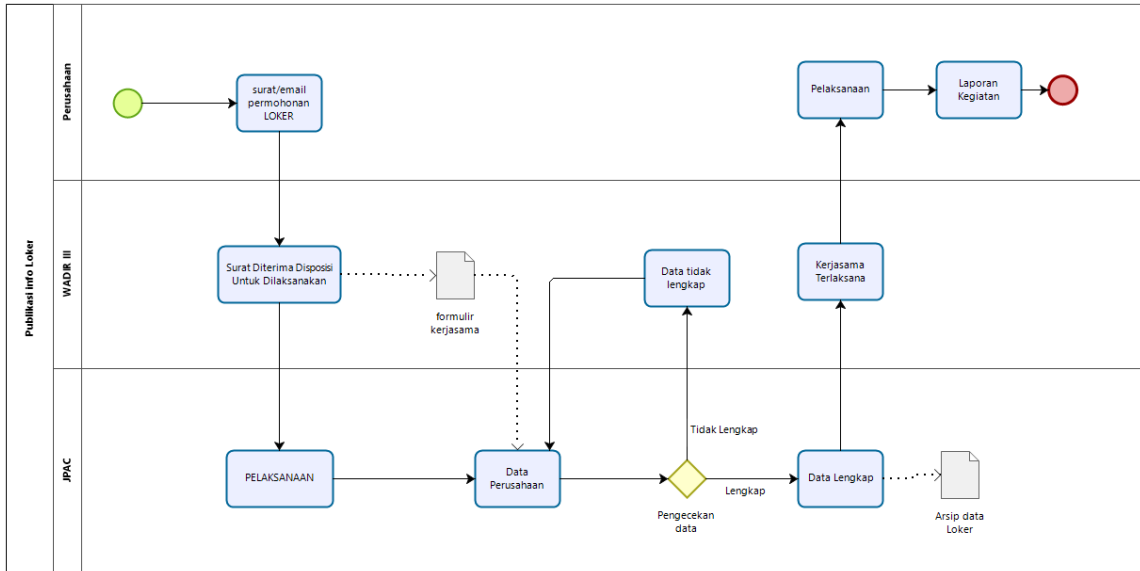

143. LAYANAN ADM UMUM & KEUANGAN



Powered by
bizagi
Modeler

144. LAYANAN TATA USAHA



Powered by
bizagi
Modeler

145. KESEKRETARIATAN



146. PENERBITAN NASKAH DINAS DIREKTUR

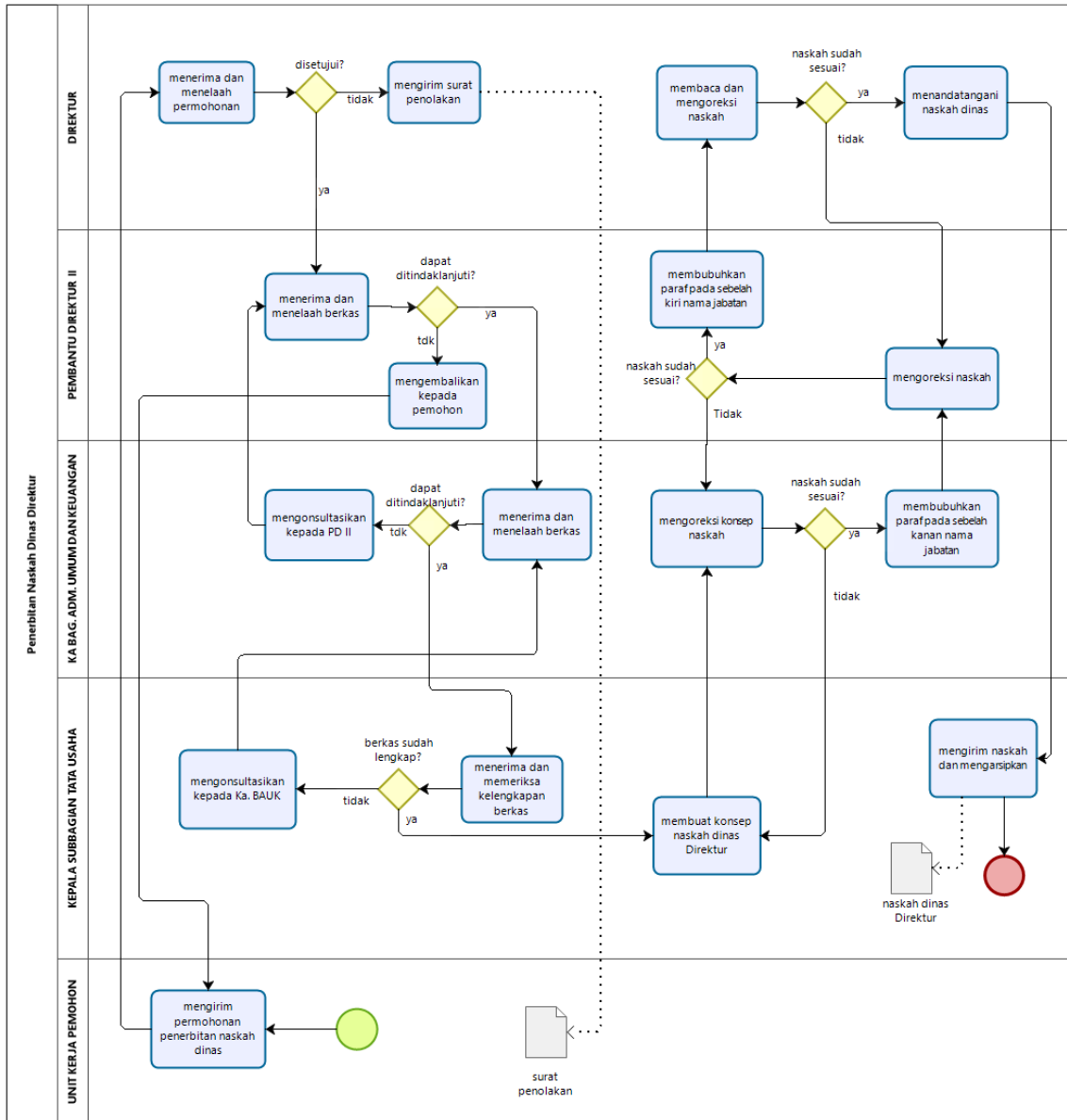

147. PENDISTRIBUSIAN NASKAH DINAS

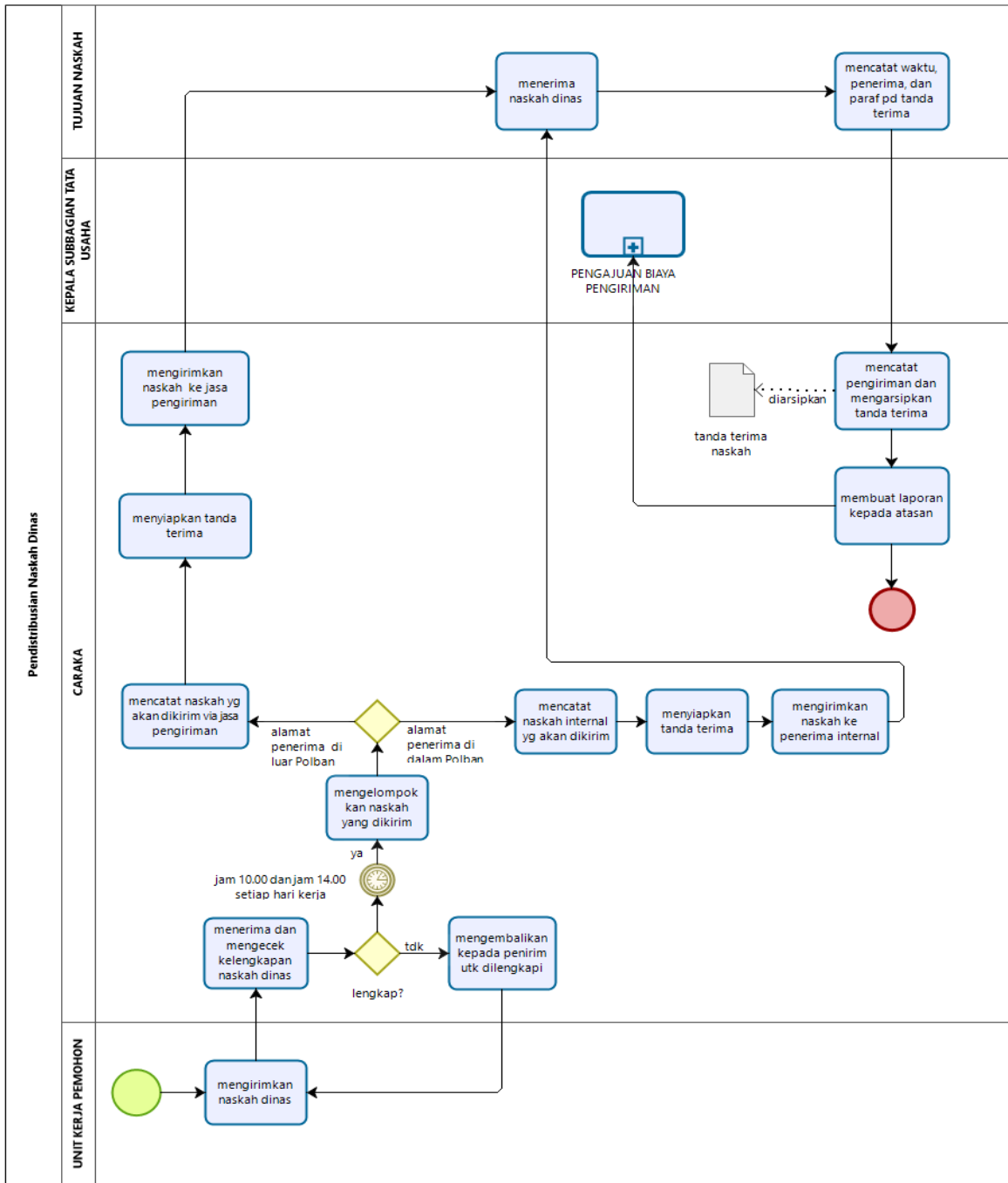

148. PENGAJUAN KEBUTUHAN BARANG DAN JASA

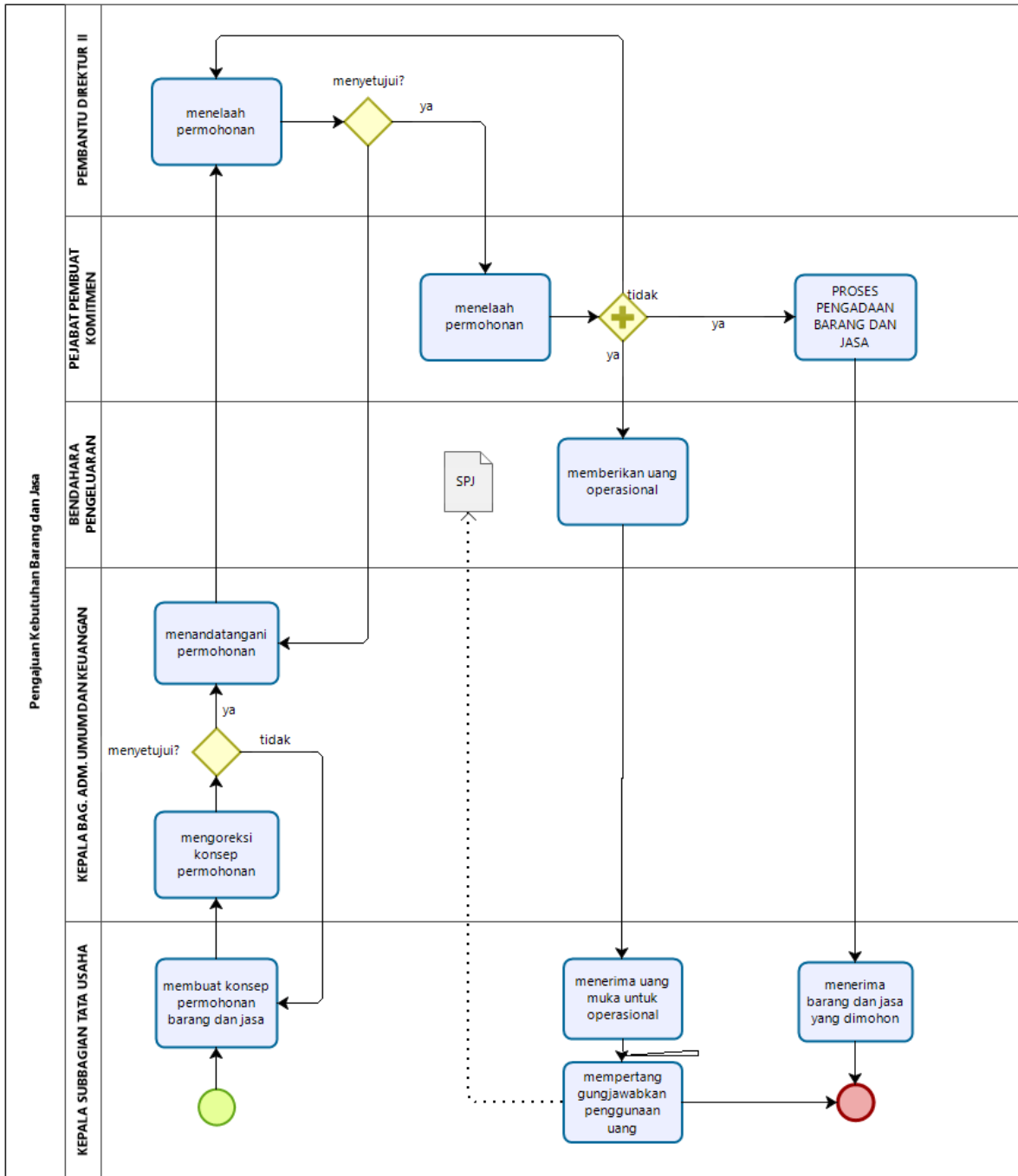

149. PENERBITAN SK KEGIATAN, KEPANITIAAN, DAN LAINNYA

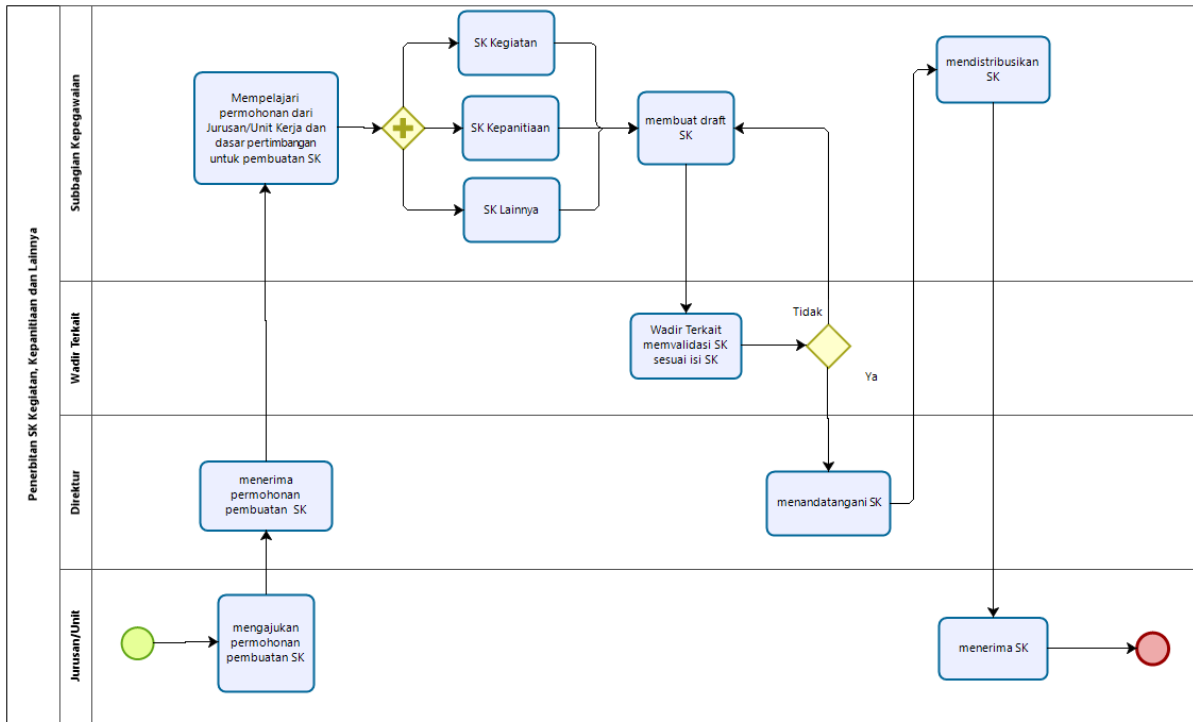

150. PENGELOLAAN SURAT MASUK (UNIT KERJA LAIN)

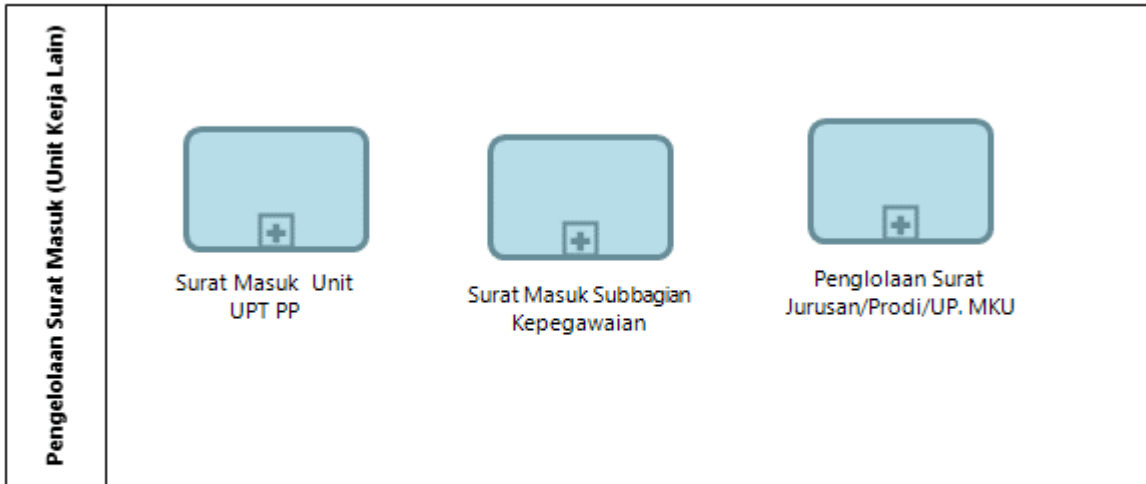

151. SURAT MASUK UNIT UPT PP

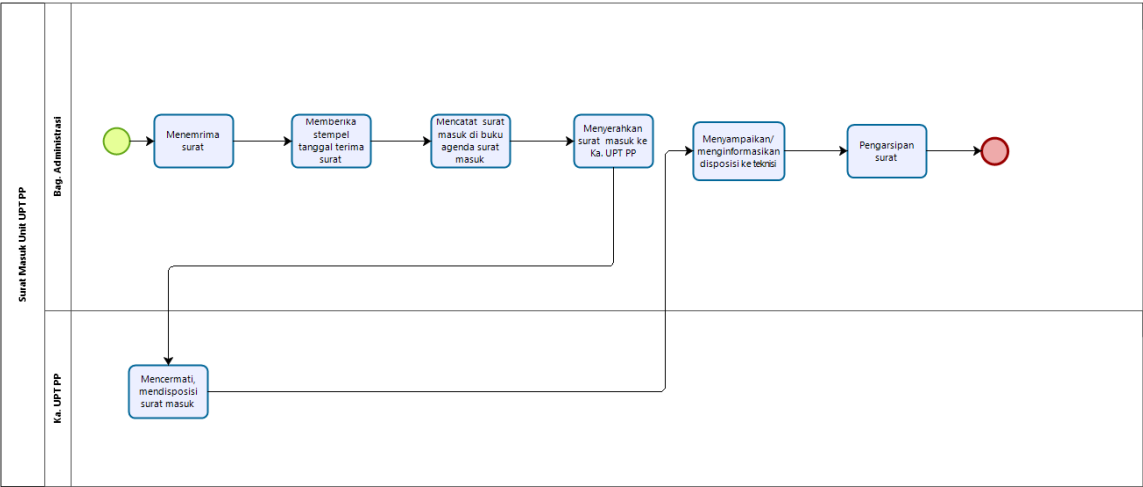

152. SURAT MASUK UNIT KEPEGAWAIAN

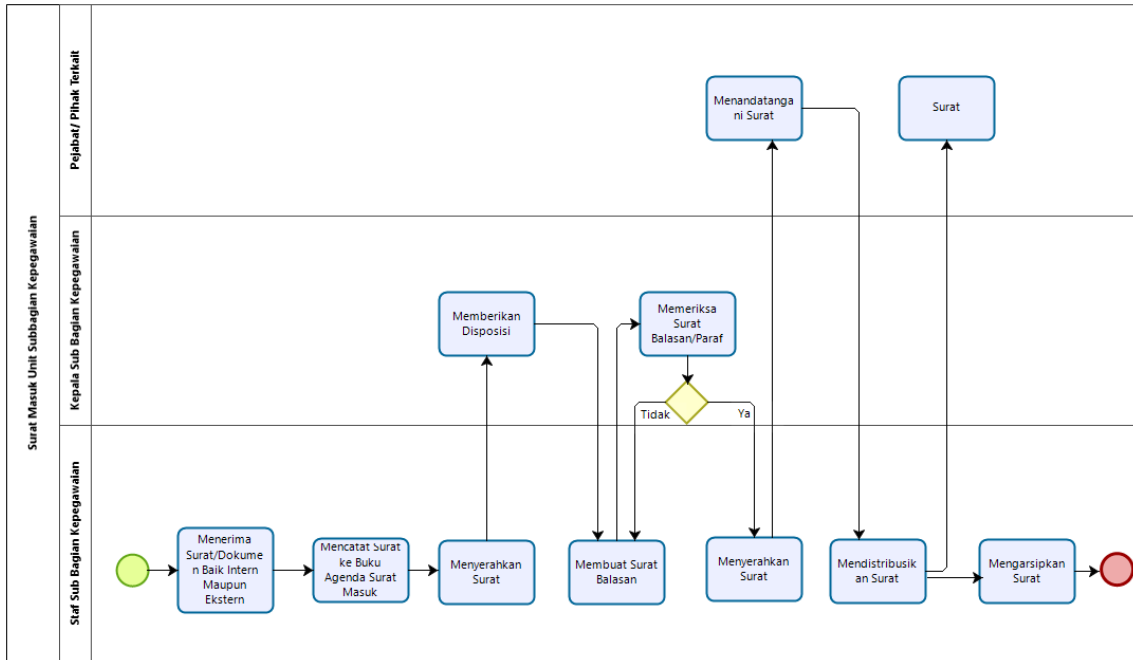

Powered by **bizagi** Modeler

153. PENGELOLAAN SURAT JURUSAN/PRODI/UP.MKU

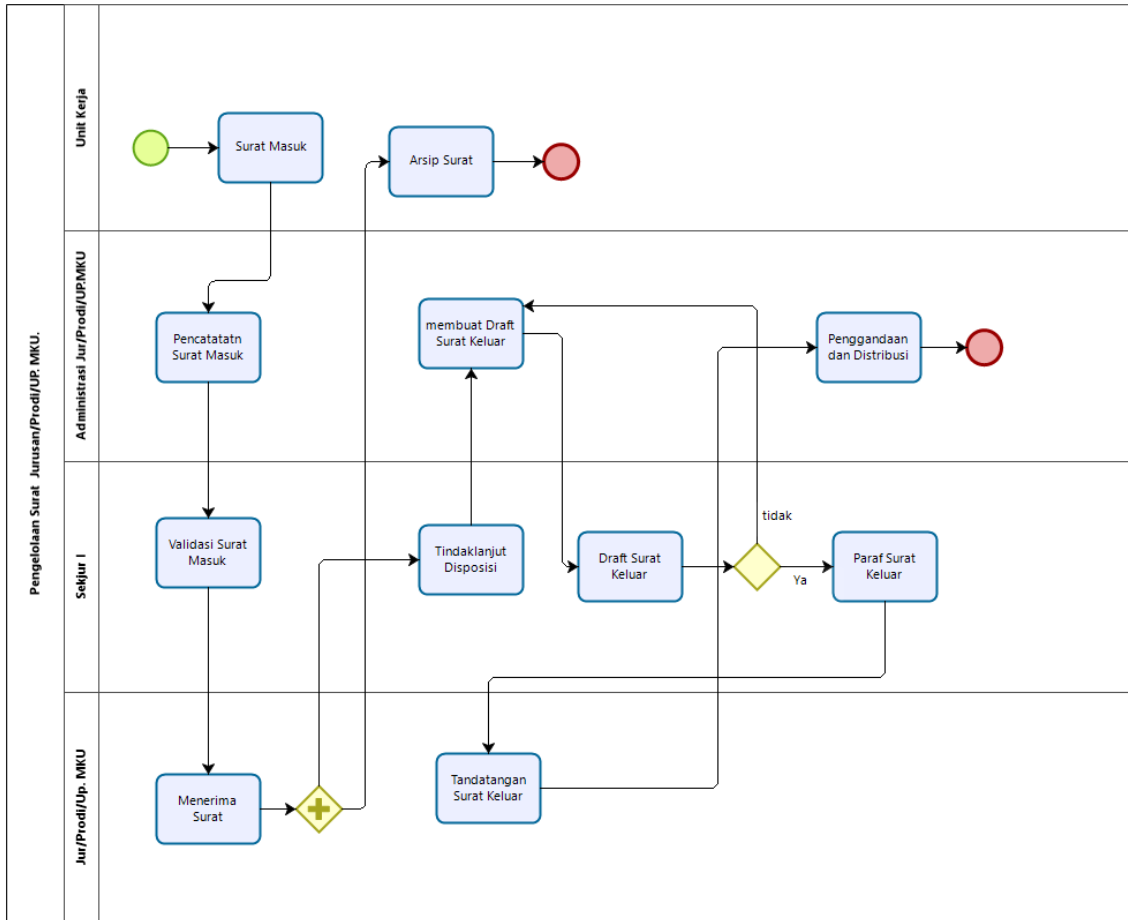

154. PENGELOLAAN SURAT KELUAR (UNIT KERJA LAIN)

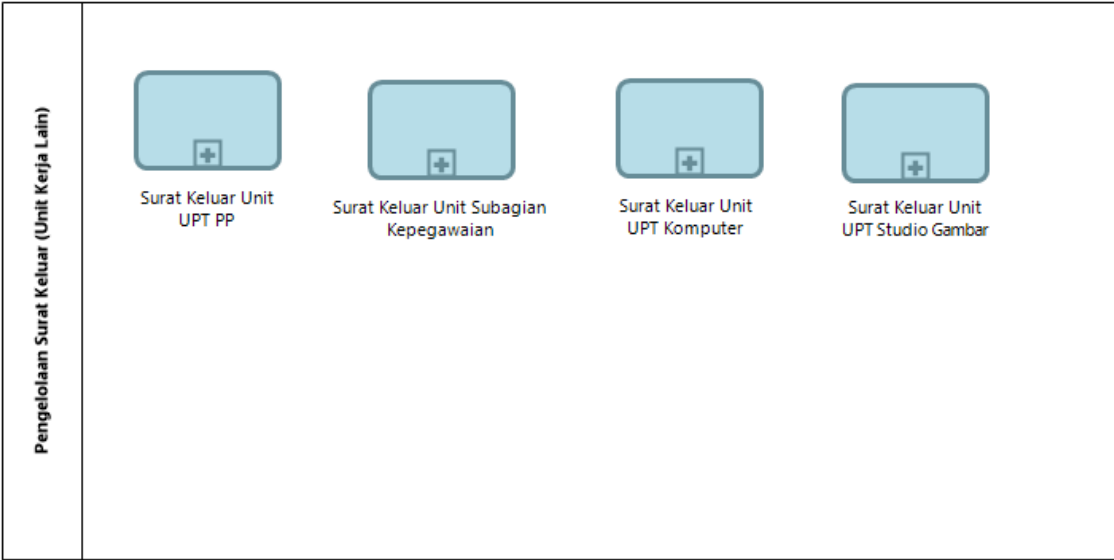

155. SURAT KELUAR UPT PP

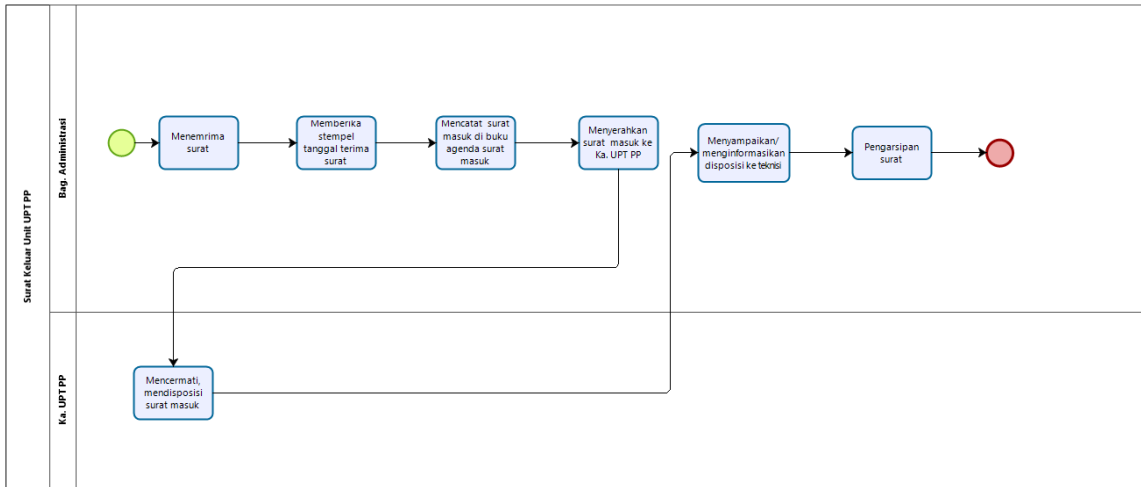

156. SURAT KELUAR UNIT SUBAGIAN KEPEGAWAIAN

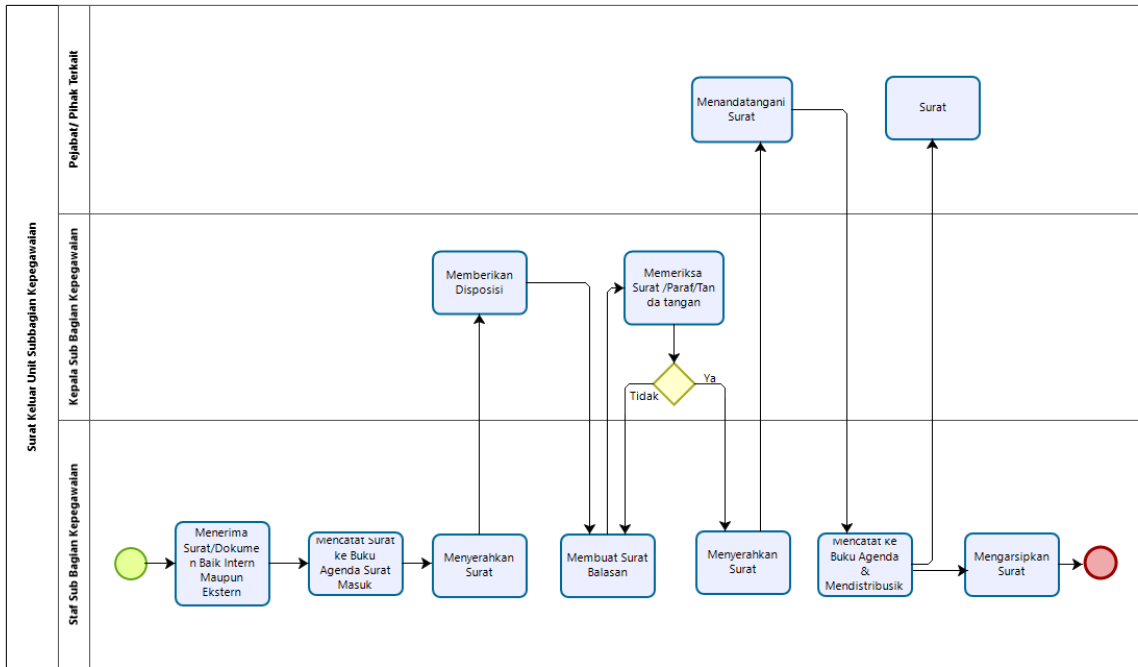

Powered by bizagi Modeler

157. SURAT KELUAR UNIT UPT KOMPUTER

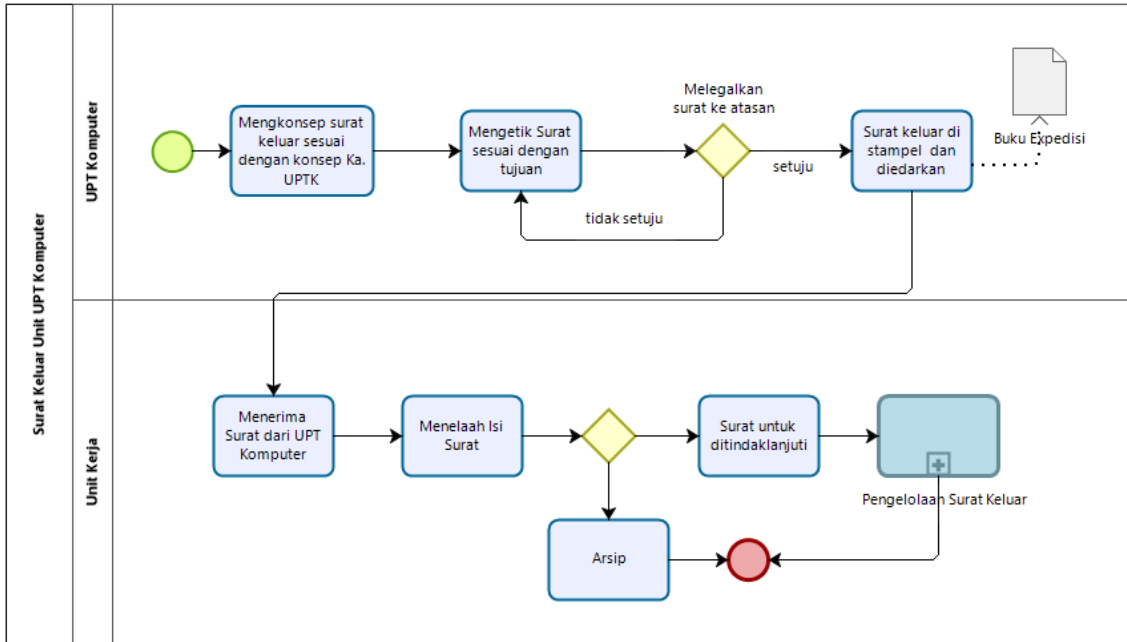

158. SURAT KELUAR UNIT UPT STUDIO GAMBAR

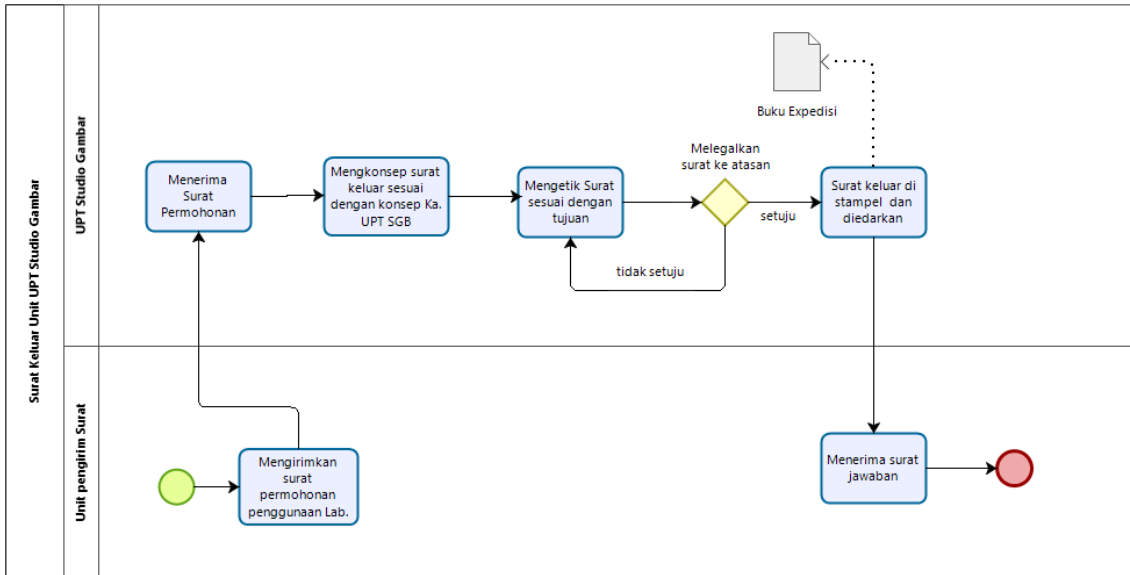

159. KERUMAHTANGGAAN

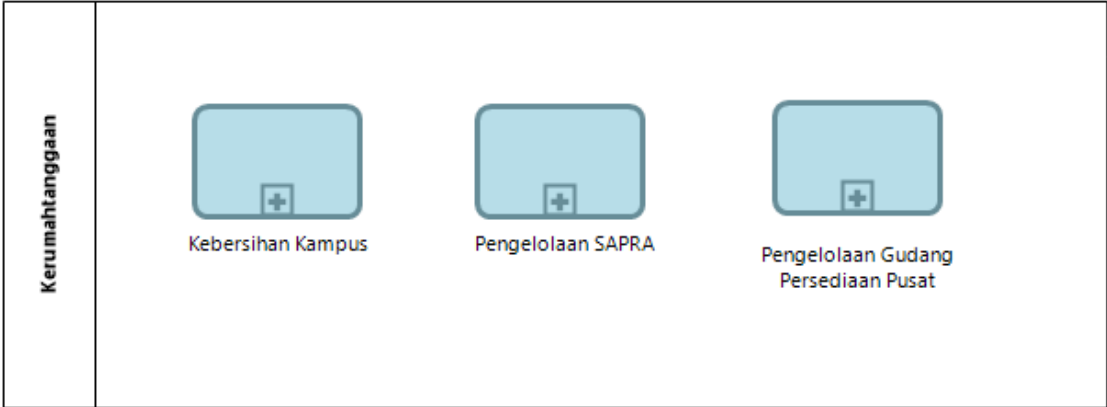

160. KEBERSIHAN KAMPUS



161. KEBERSIHAN DALAM GEDUNG

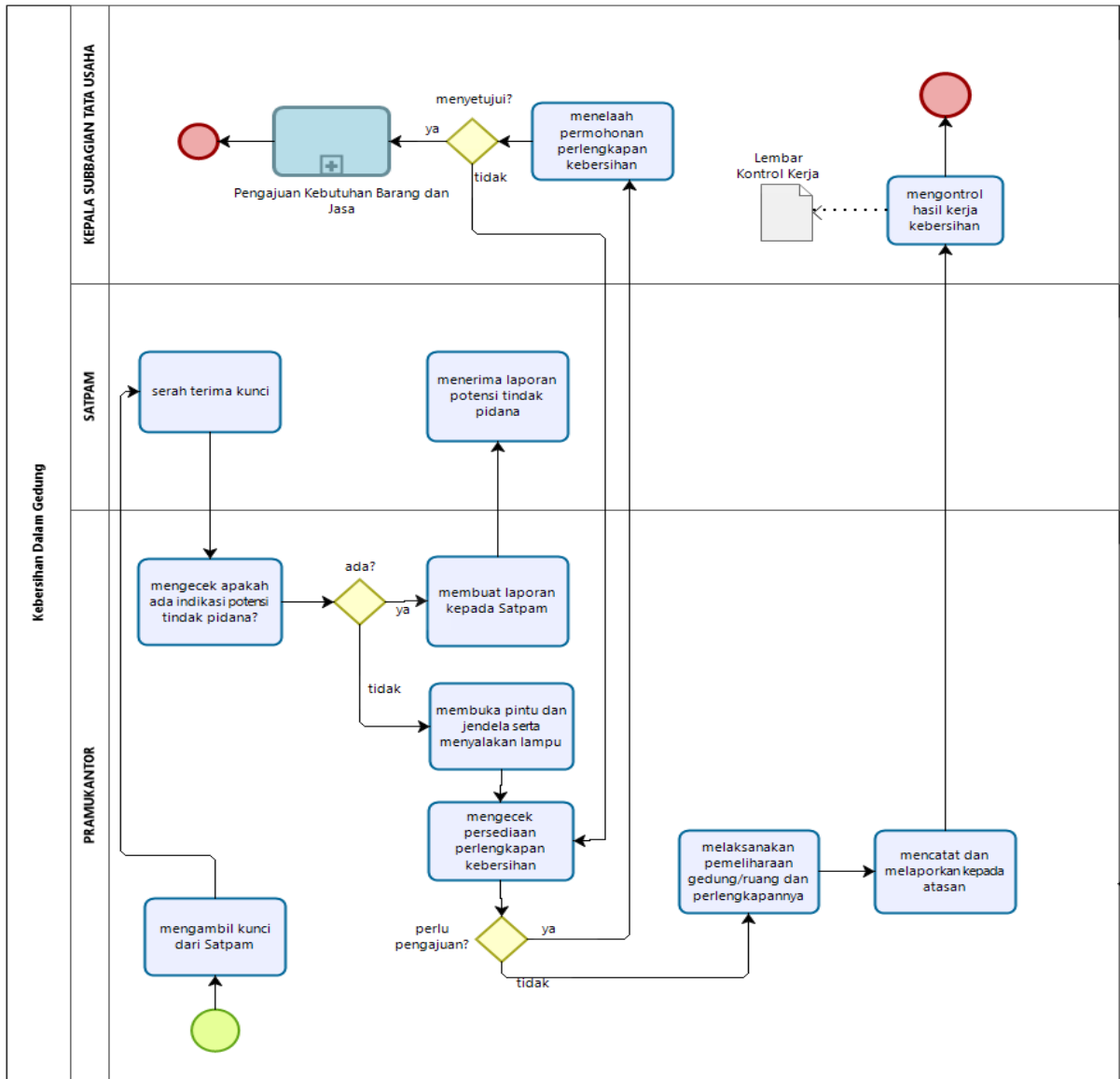

162. KEBERSIHAN LINGKUNGAN KAMPUS

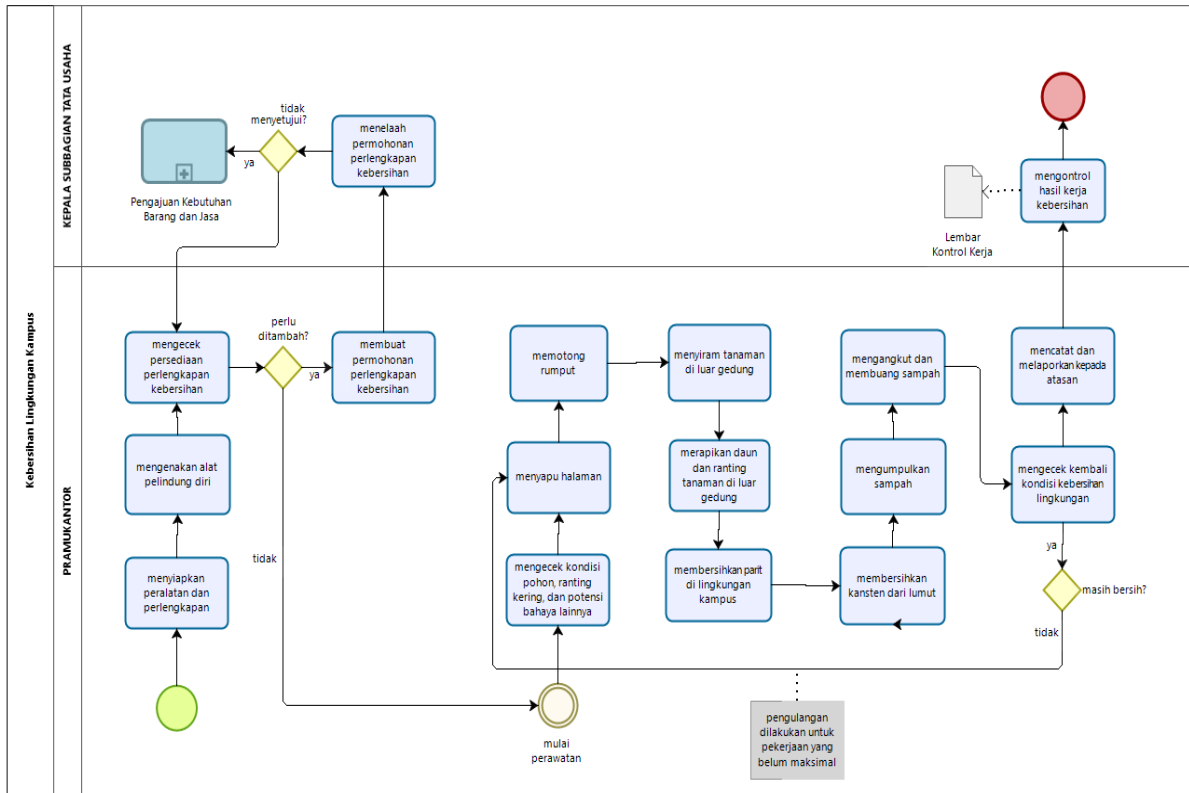

163. PENGELOLAAN SAPRA

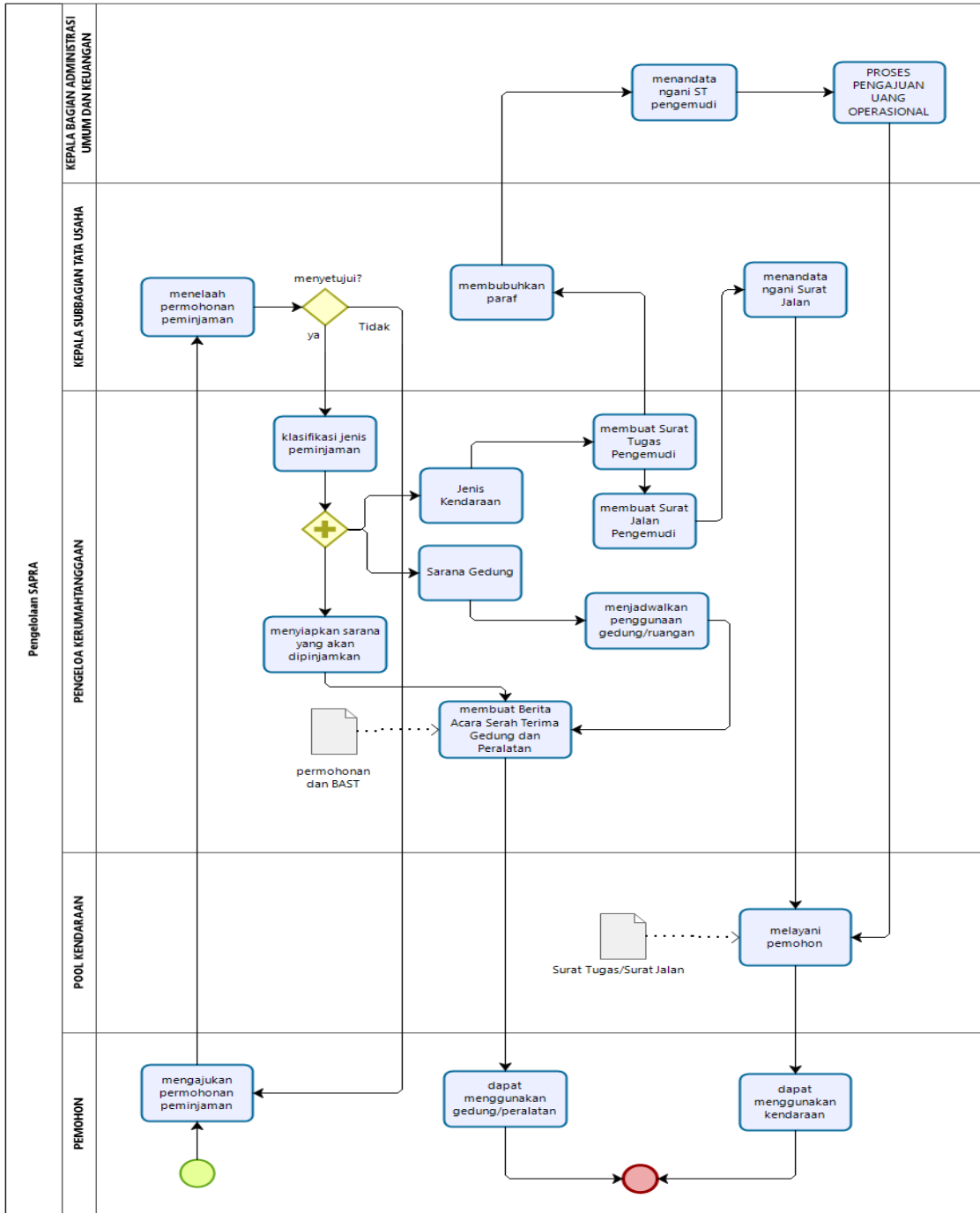

Powered by bizagi Modeler

164. PENGELOLAAN GUDANG PERSEDIAAN PUSAT

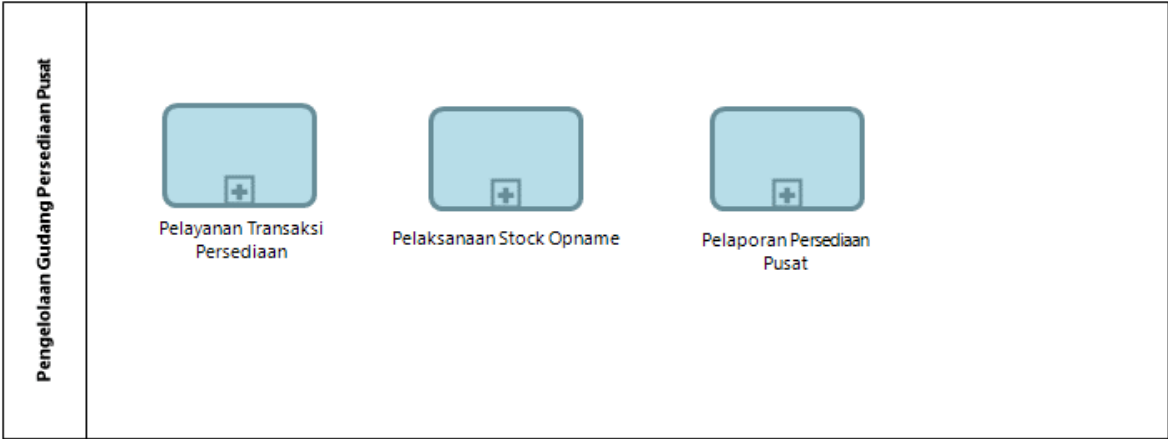

165. PELAYANAN TRANSAKSI PERSEDIAAN

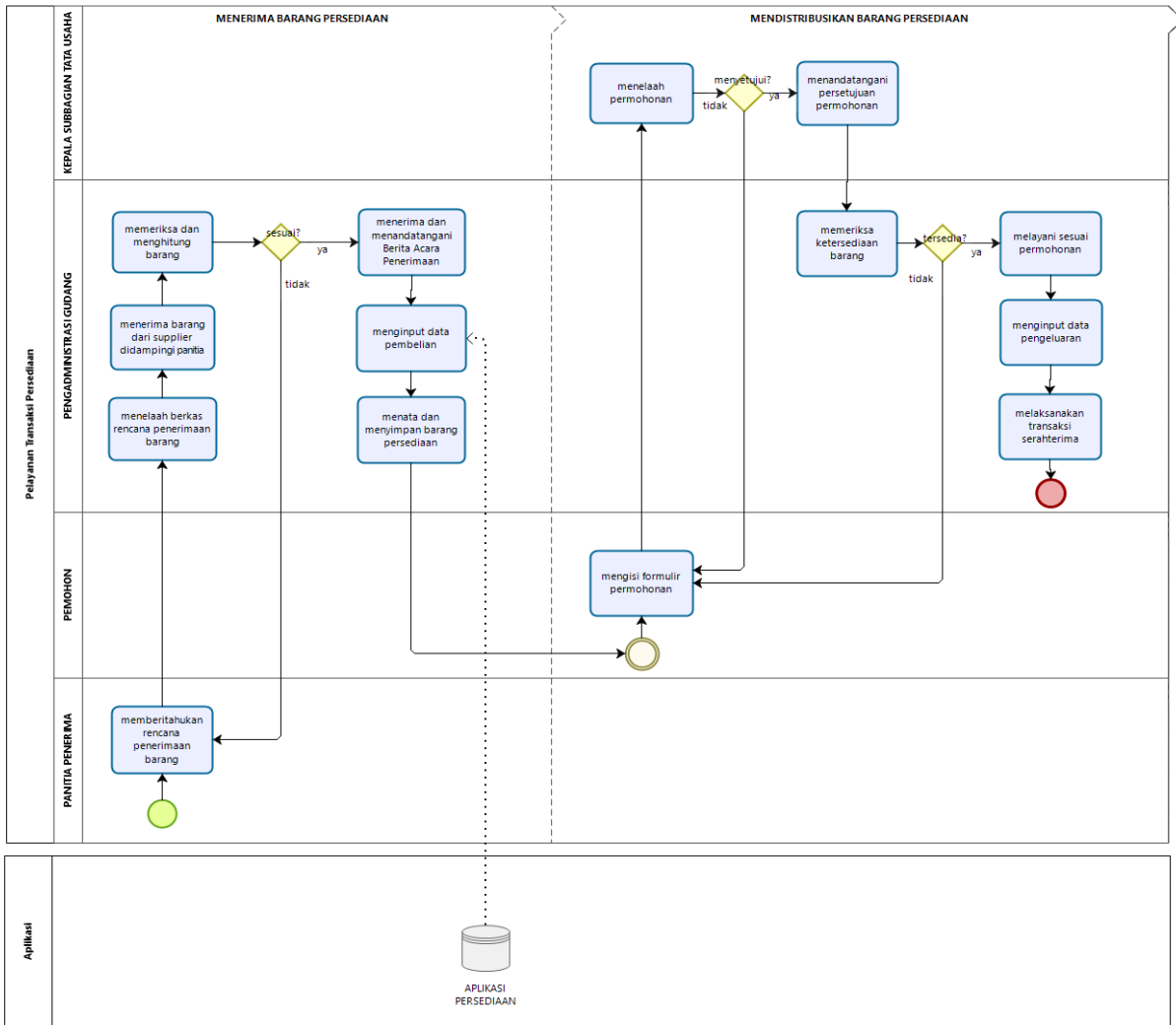

166. PELAKSANAAN STOCK OPNAME

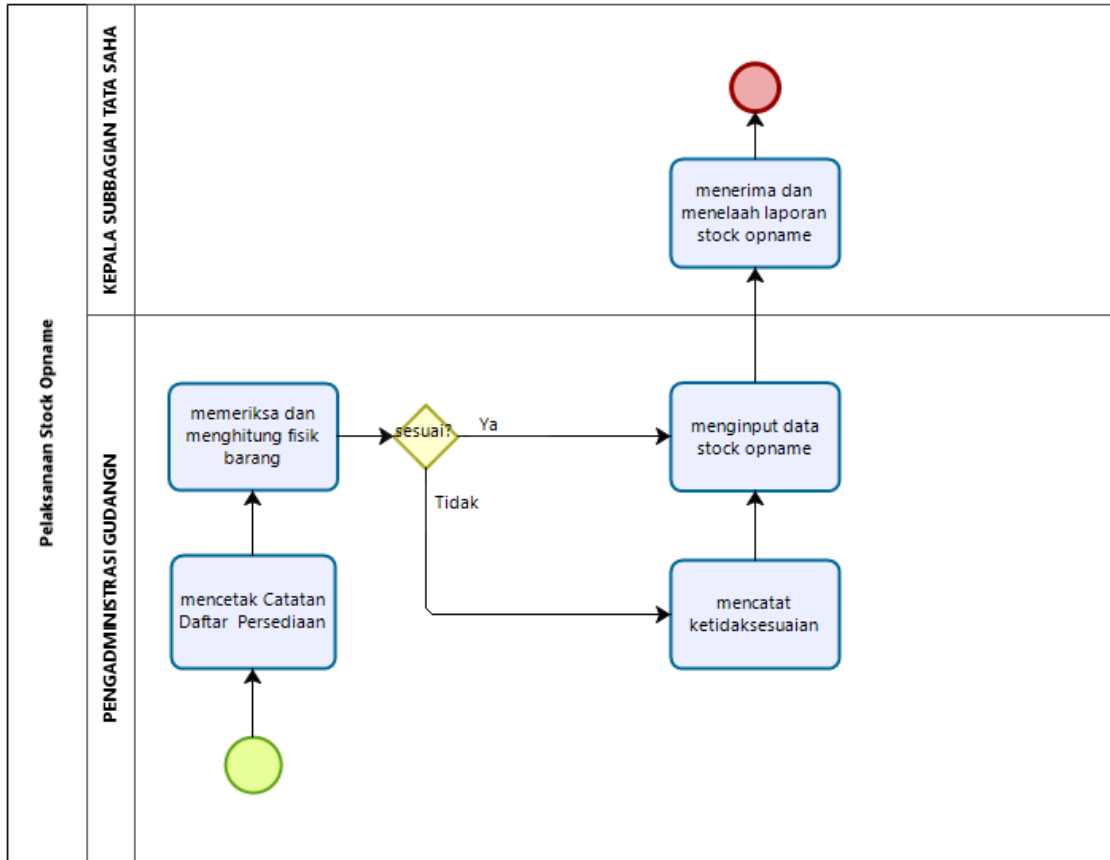

167. PELAPORAN PERSEDIAAN PUSAT

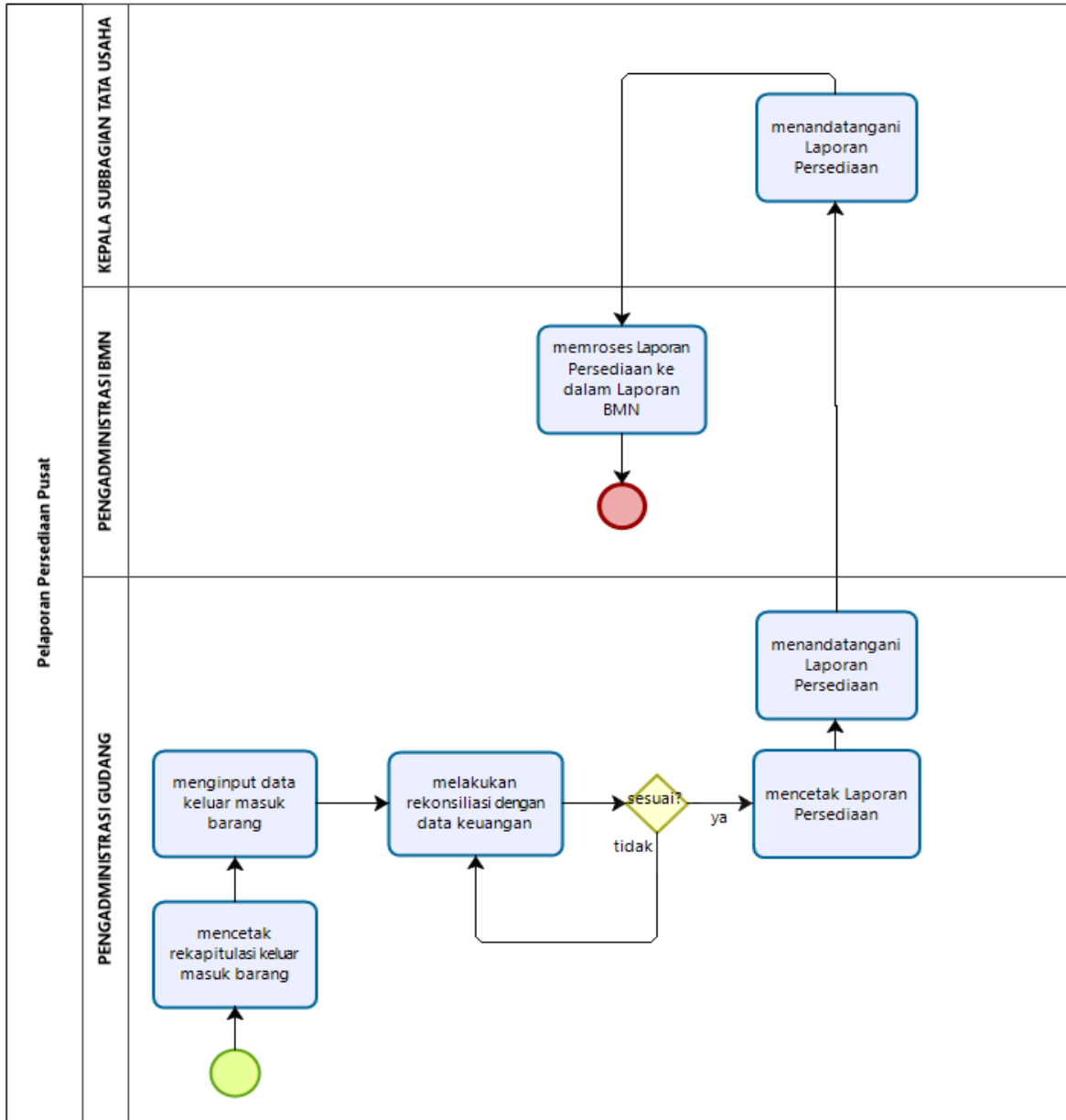

168. PENGELOLAAN BARANG MILIK NEGARA

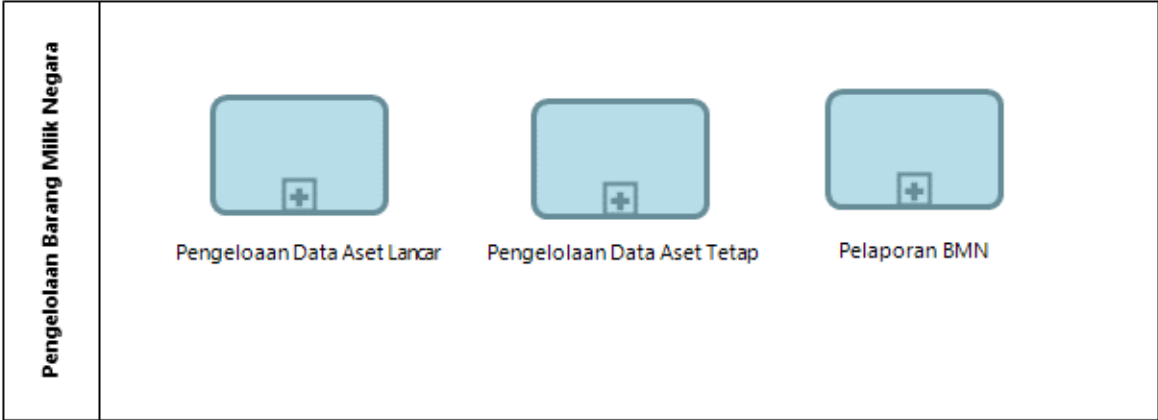

169. PENGELOLAAN DATA ASET LANCAR

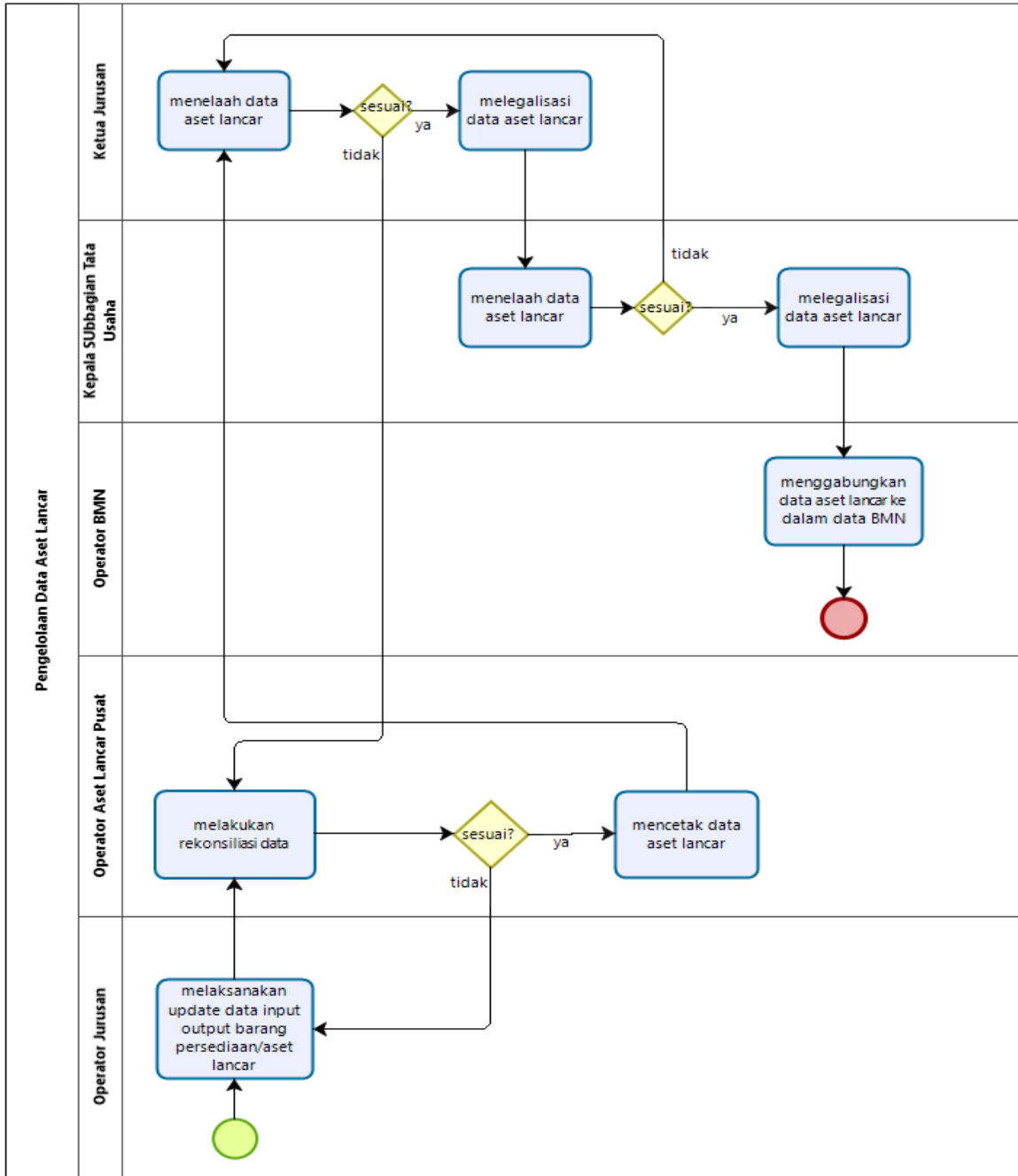

170. PENGELOLAAN DATA ASET TETAP

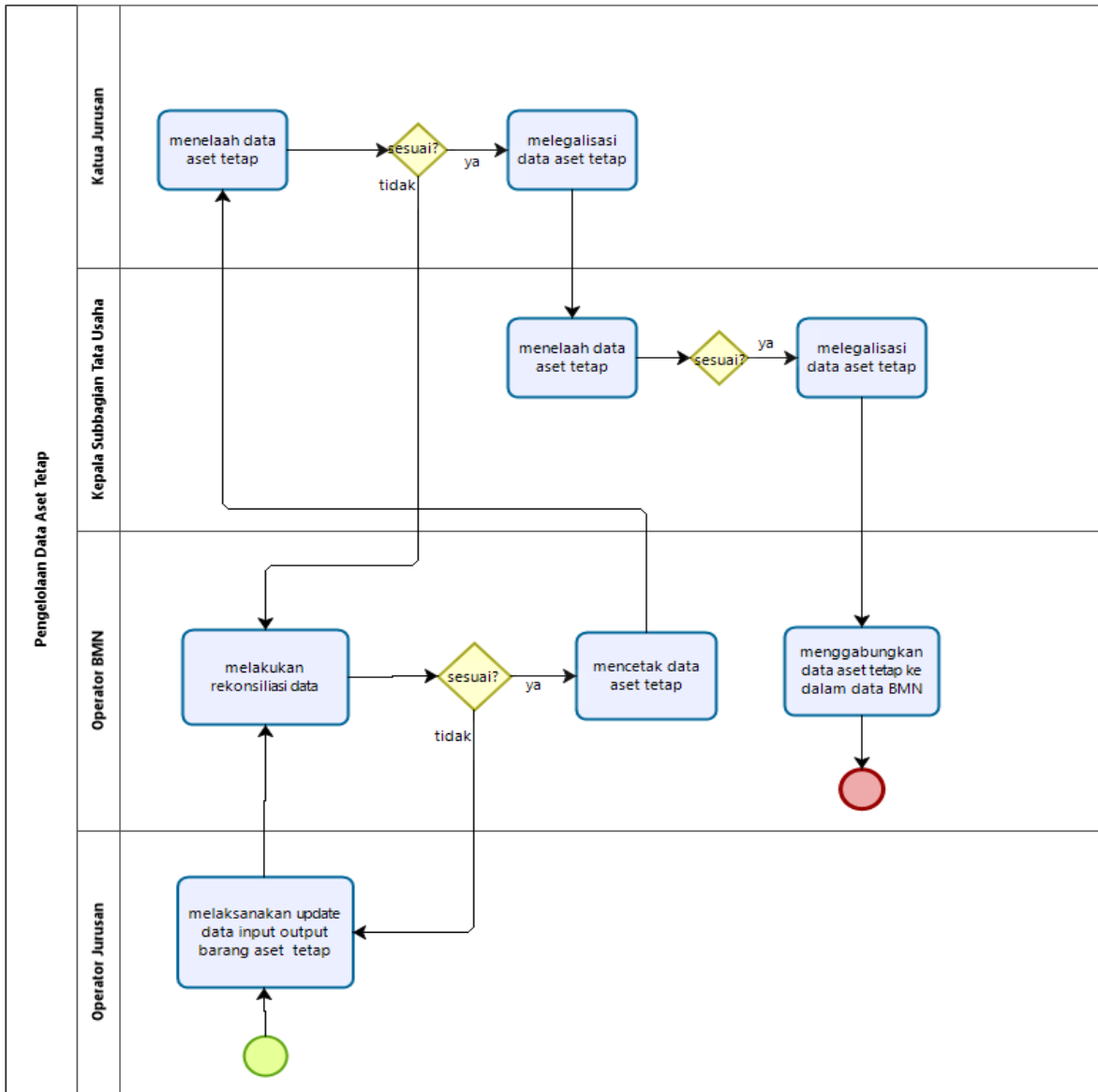

171. PELAPORAN BMN

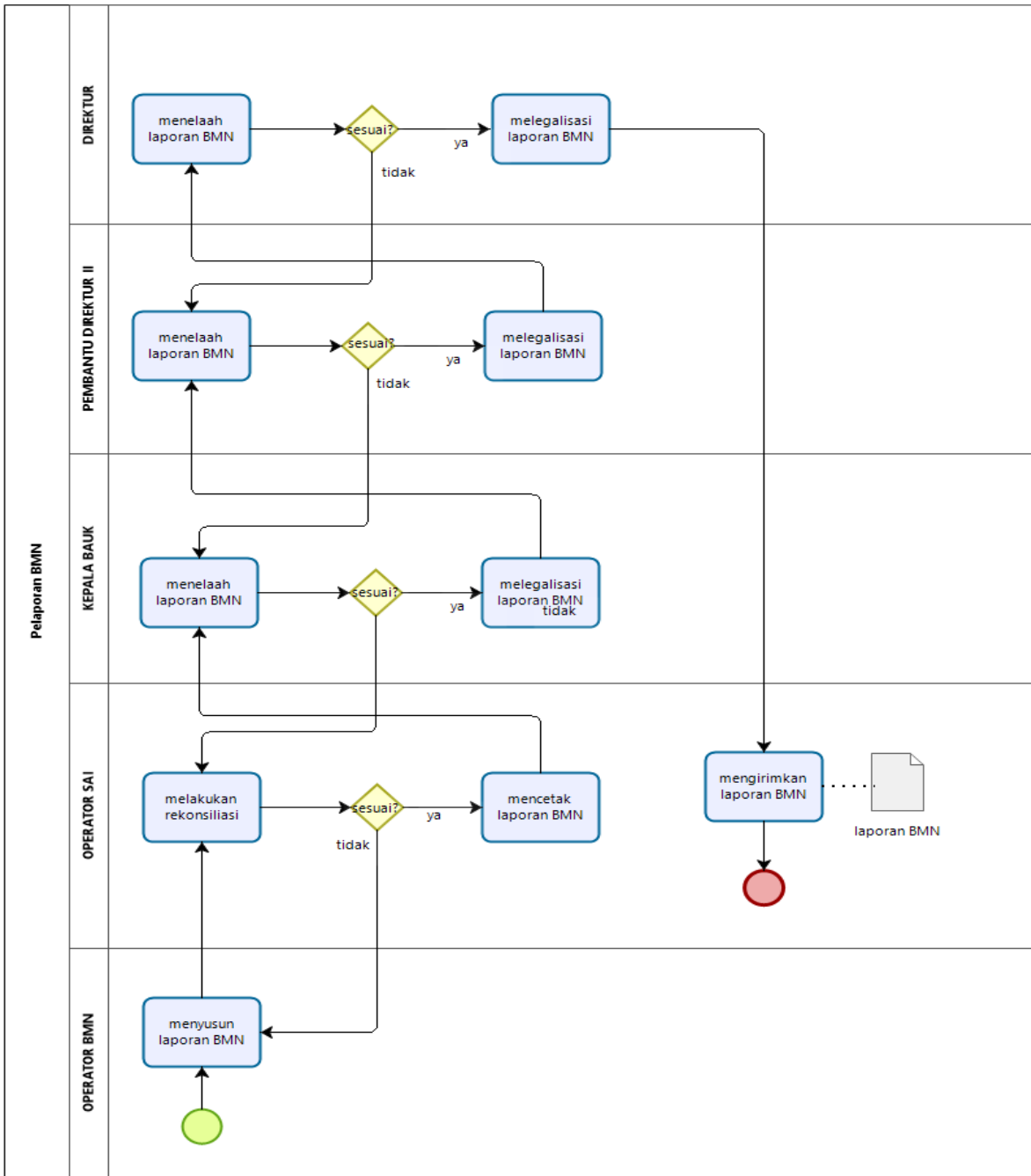

172. KEARSIPAN

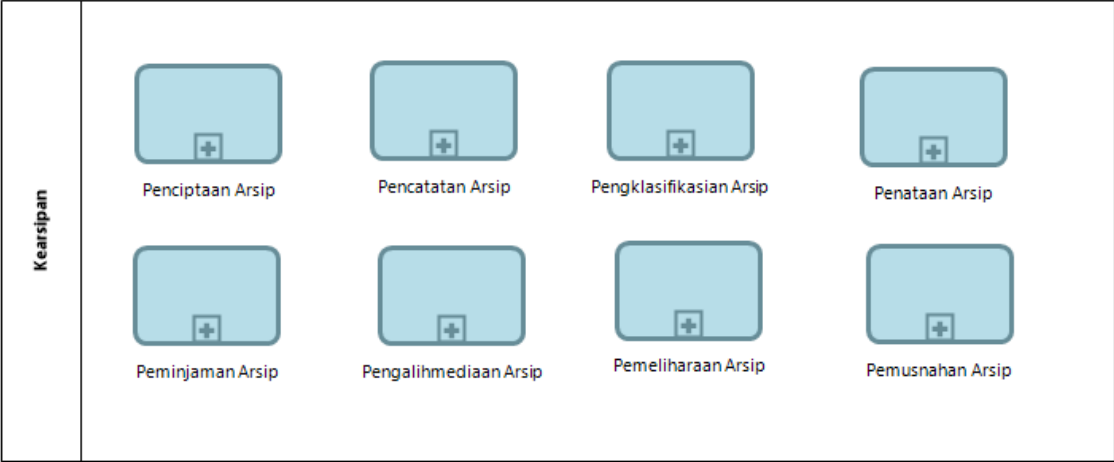

Powered by
bizagi
Modeler

173. PENCATATAN ARSIP

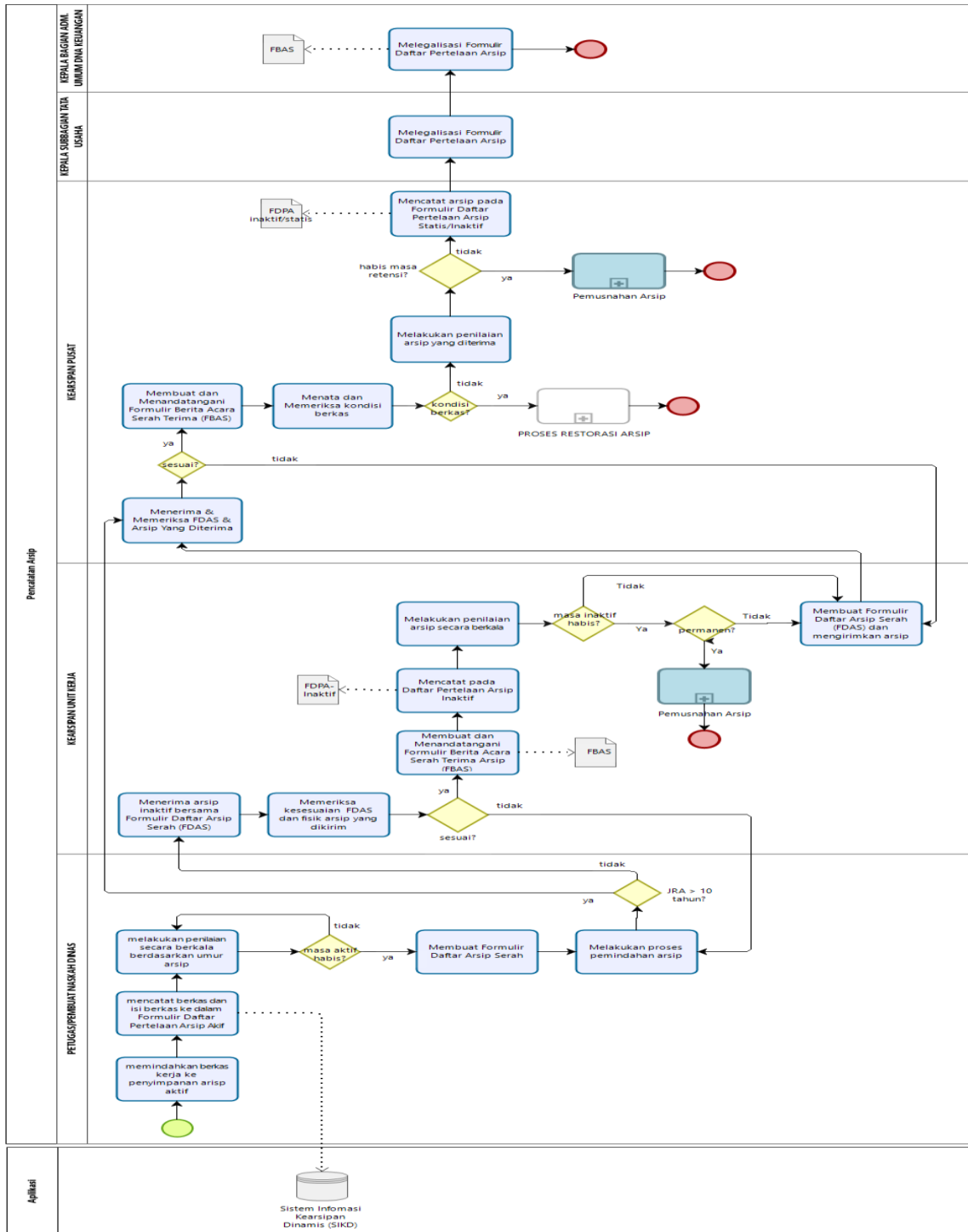

174. PENATAAN ARSIP

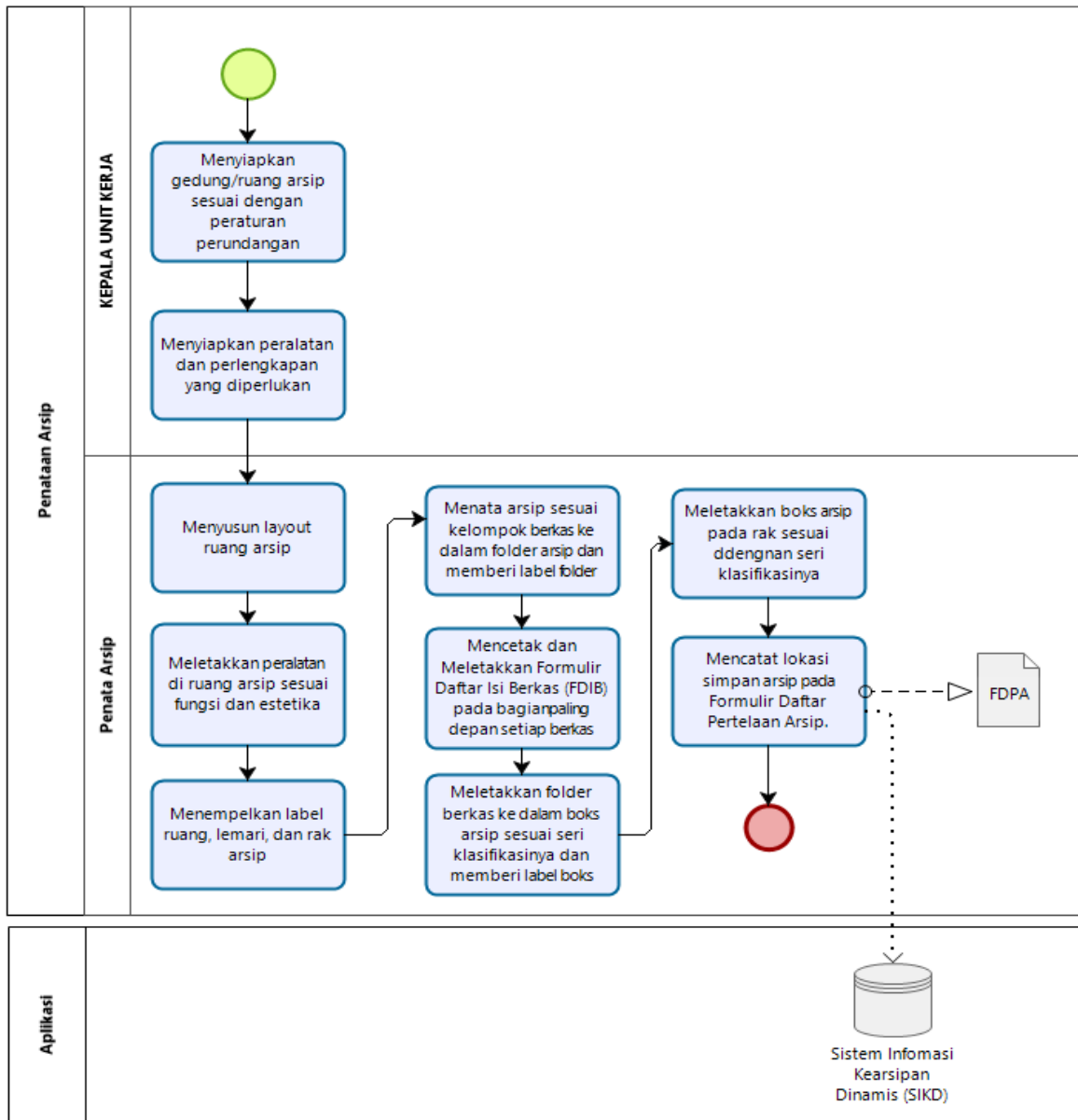

175. PENGKLASIFIKASIAN ARSIP

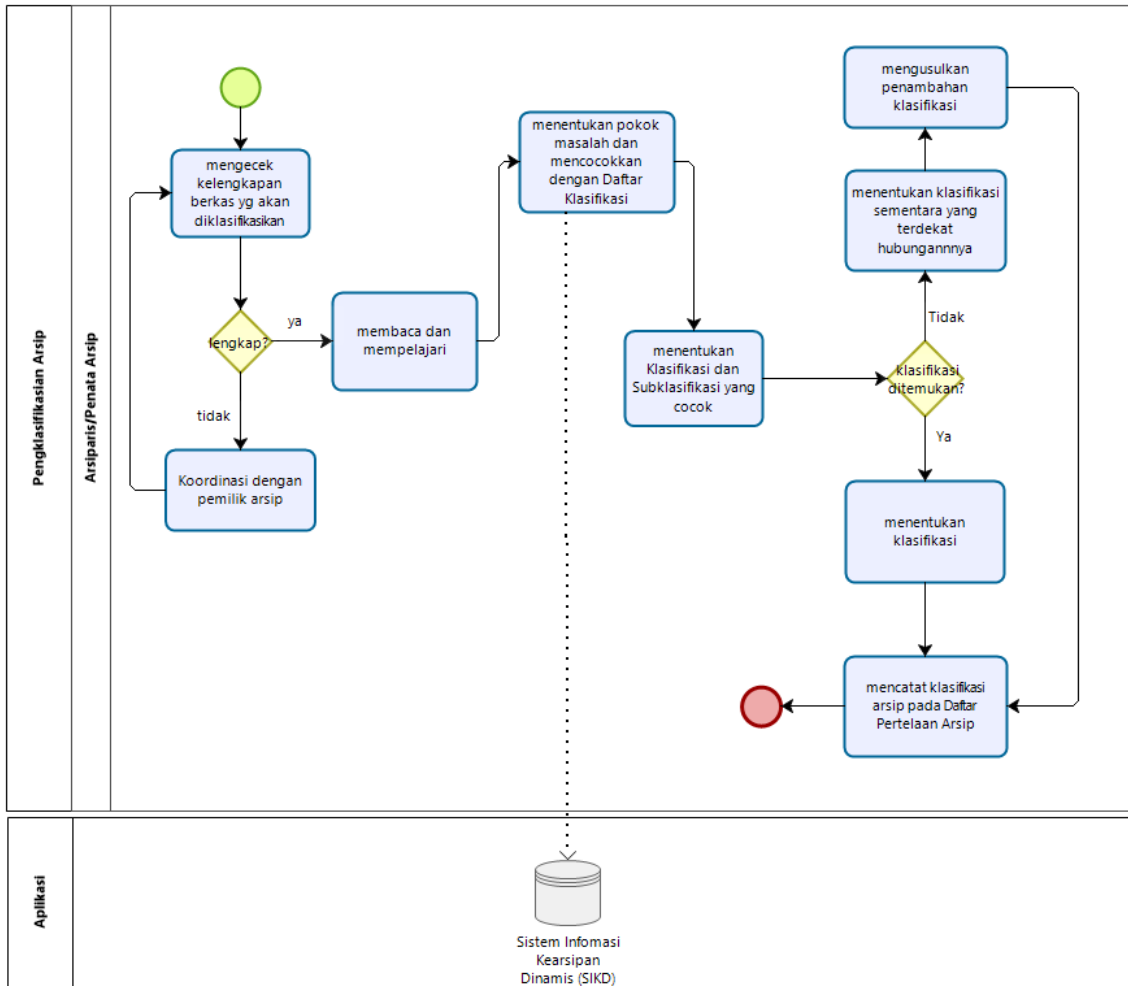

176. PEMELIHARAAN ARSIP

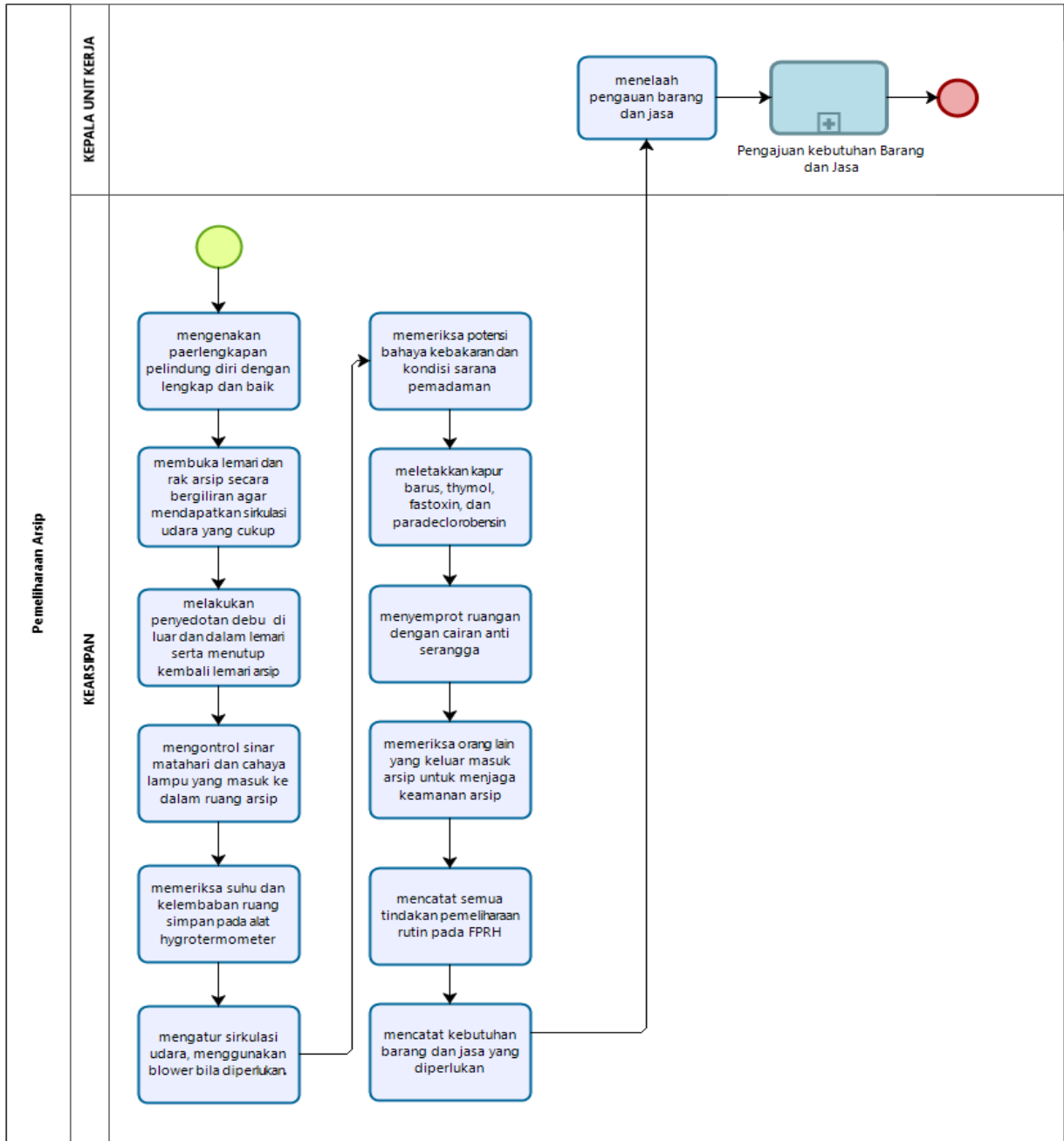

177. PEMINJAMAN ARSIP

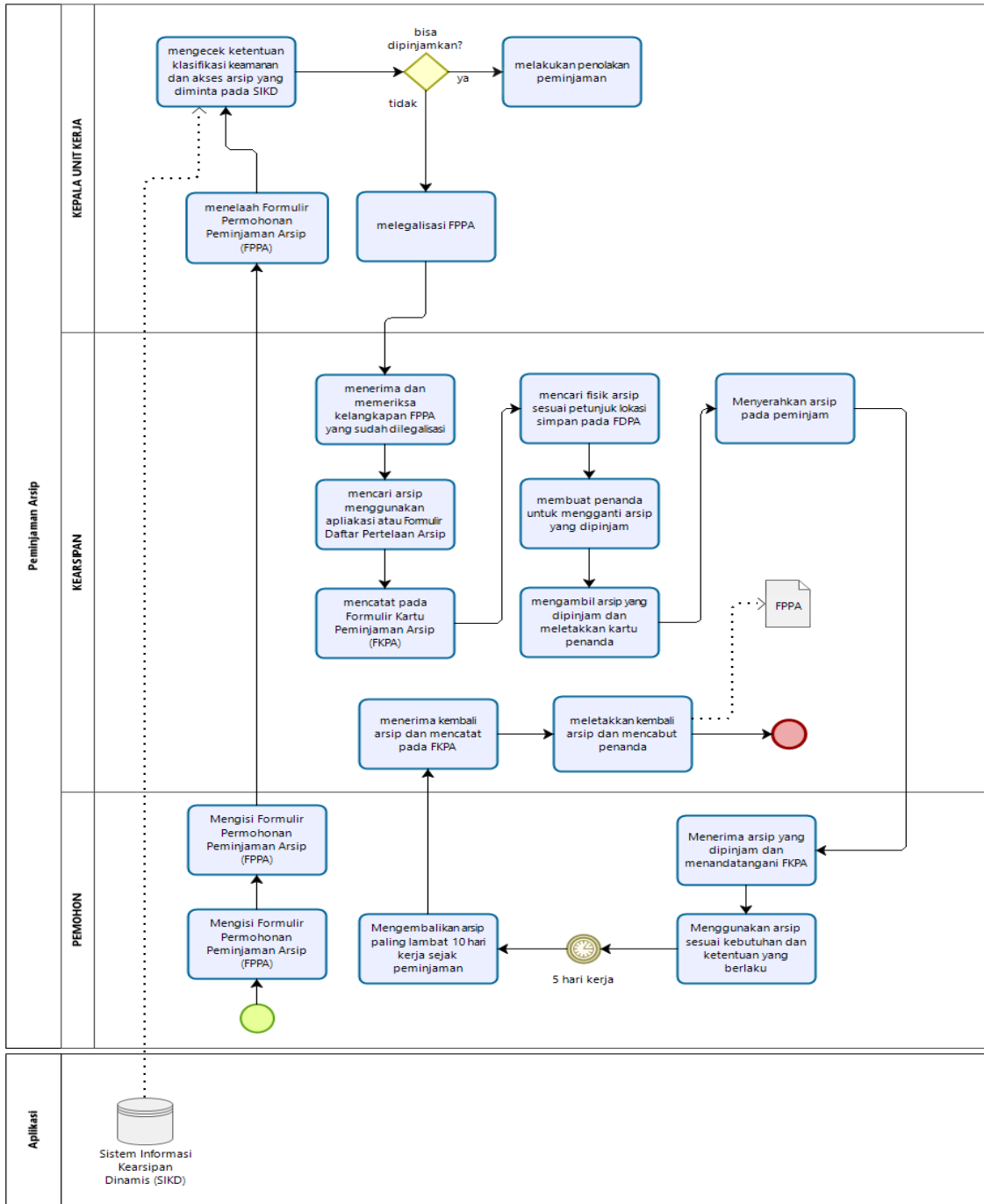

178. PENYIMPANAN ARSIP

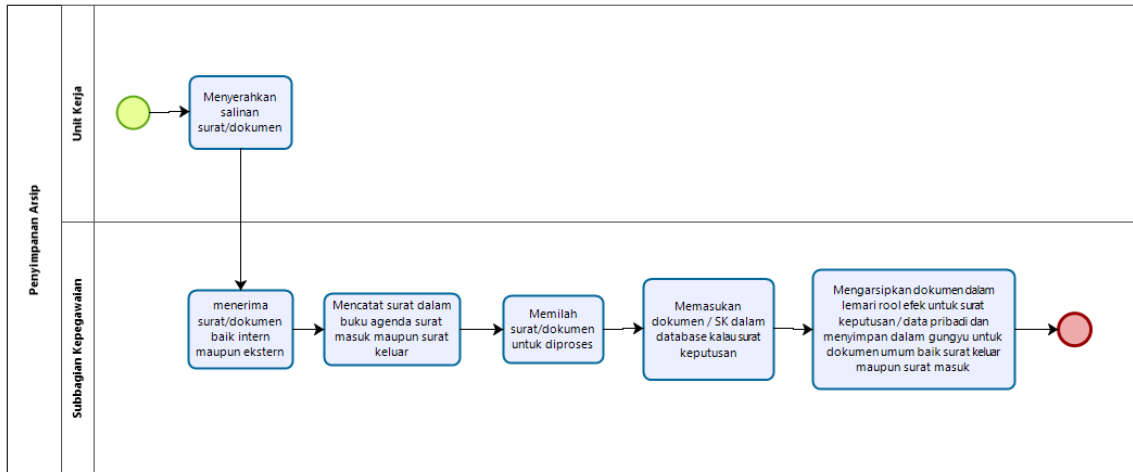

Powered by
bizagi
Modeler

179. PENGALIHMEDIAAN ARSIP

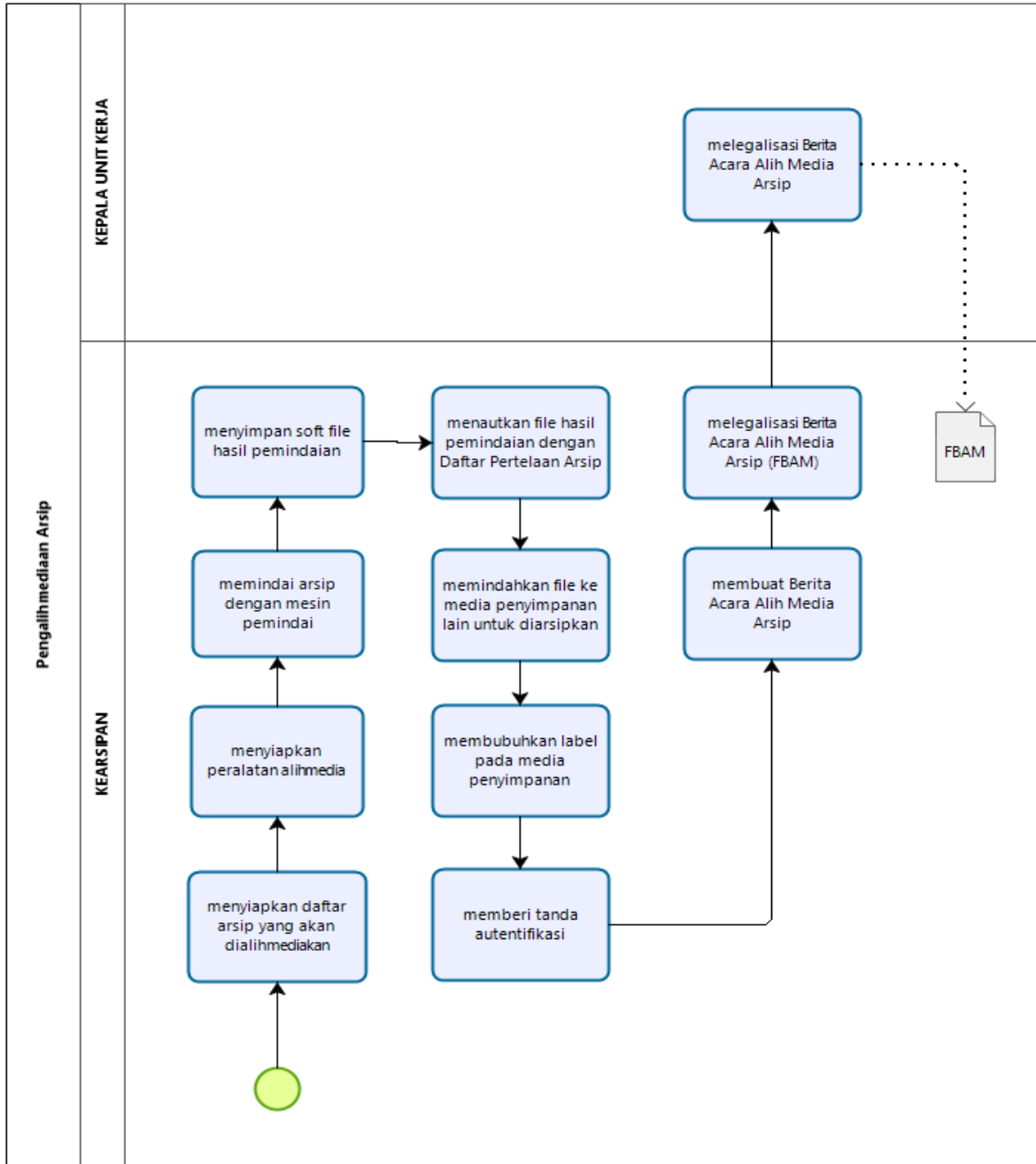

180. PENCIPTAAN ARSIP

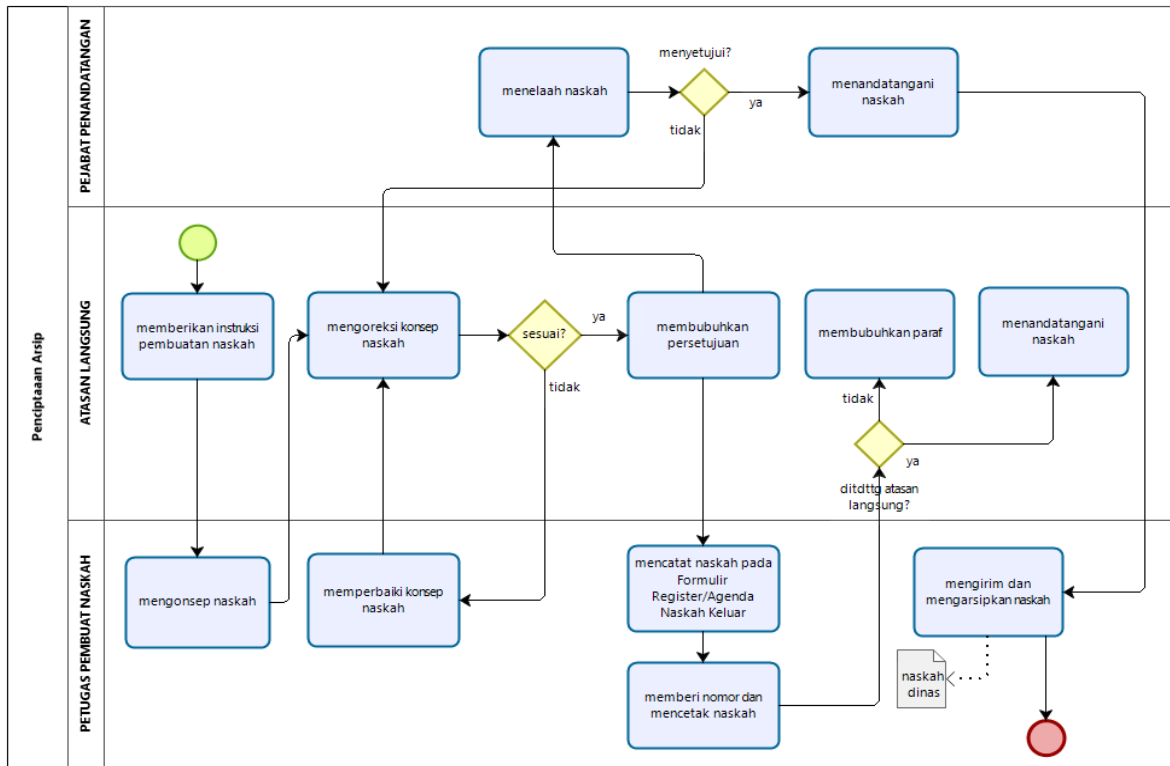

181. PEMUSNAHAN ARSIP

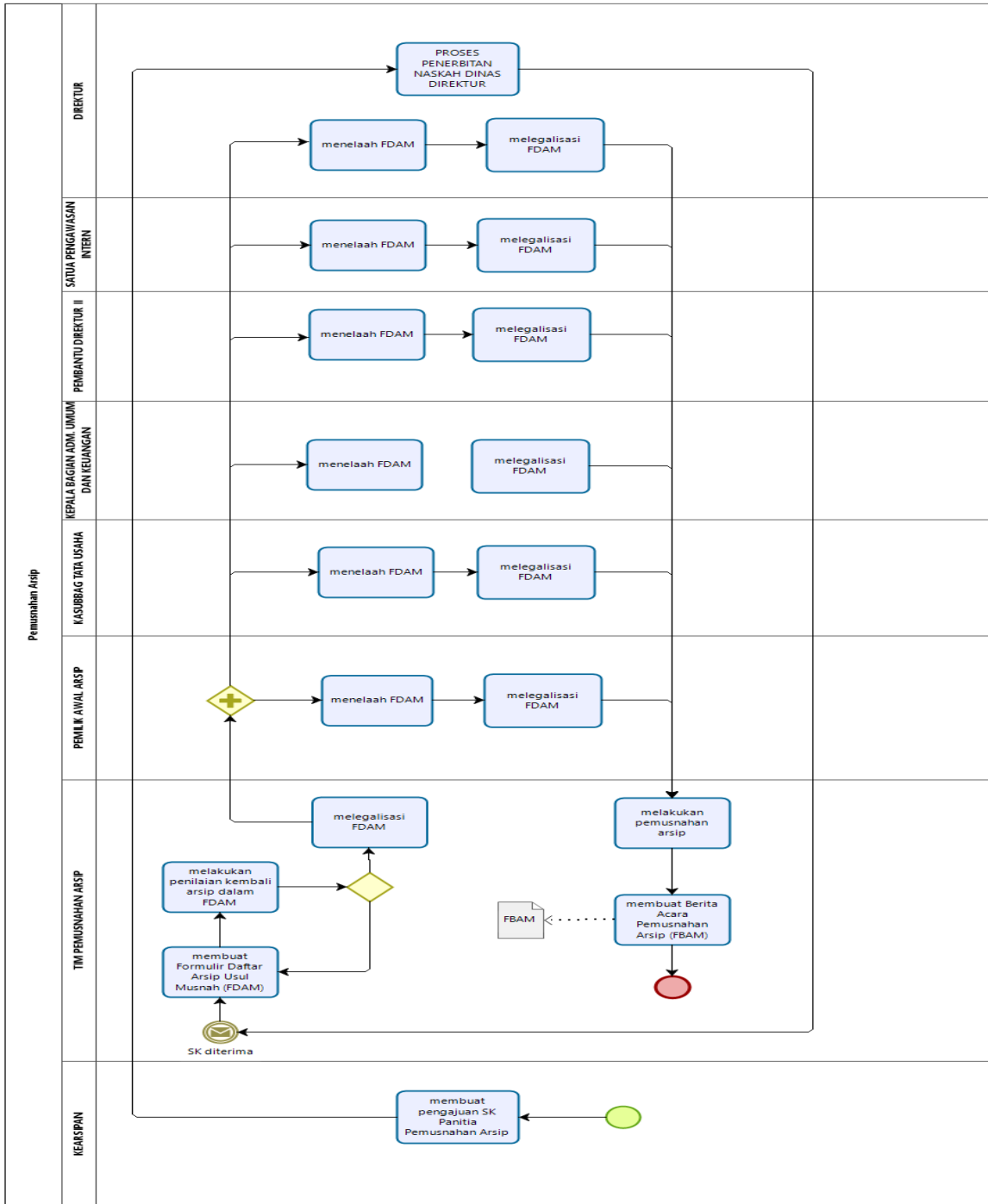

182. KEPEGAWAIAN

Kepegawaian	Penerimaan CPNS	
	Pengalokasian CPNS	
	Penerimaan Pegawai Kontrak	
	Pangkat & Jabatan	
	Pengembangan Karir	
	Rotasi Pegawai	
	Pembatas Sifat Pekerjaan (PS)	
	Penilaian Kinerja	
	Proteksi dan Tunjangan	
	Penghargaan	
	Dipin	
	Pensiun/Pensiunan	
	Cuti	
Dokumentasi Pegawai		

183. PENERIMAAN FORMASI CPNS

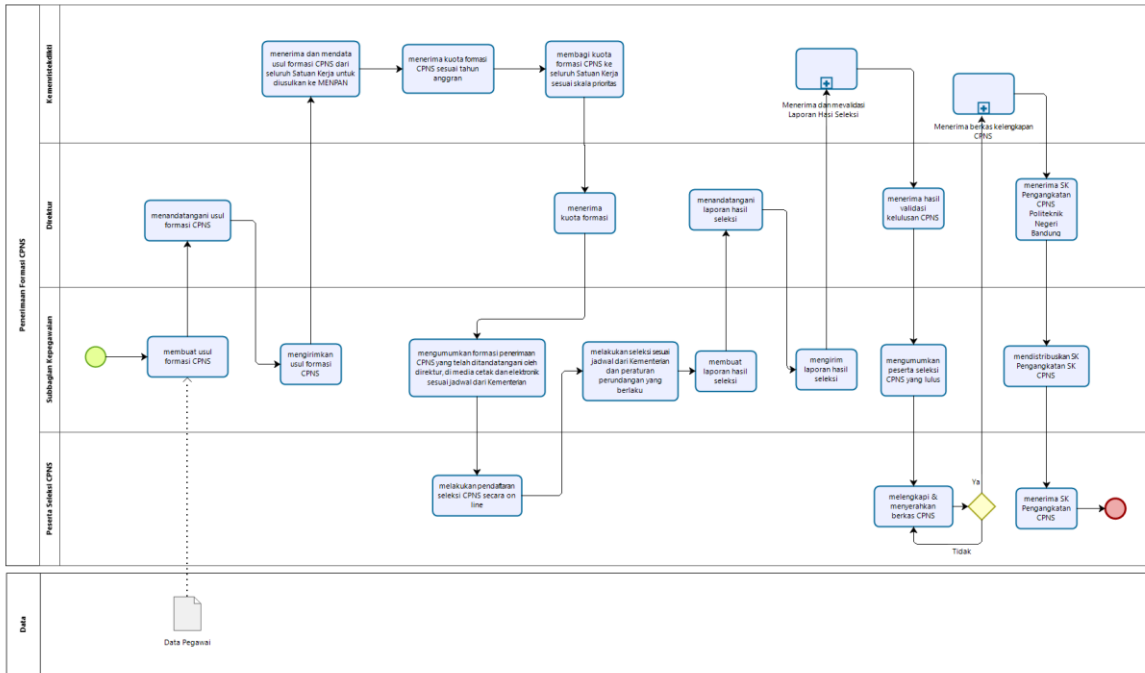

184. PENERIMAAN CPNS

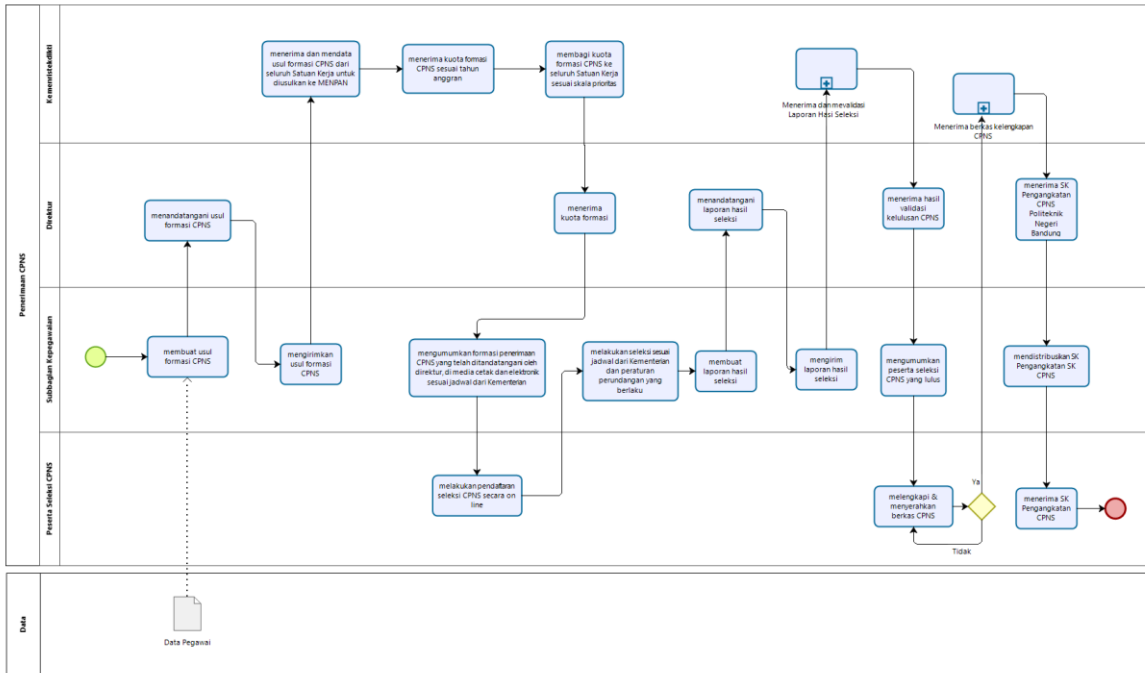

185. PENERIMAAN PEGAWAI KONTRAK

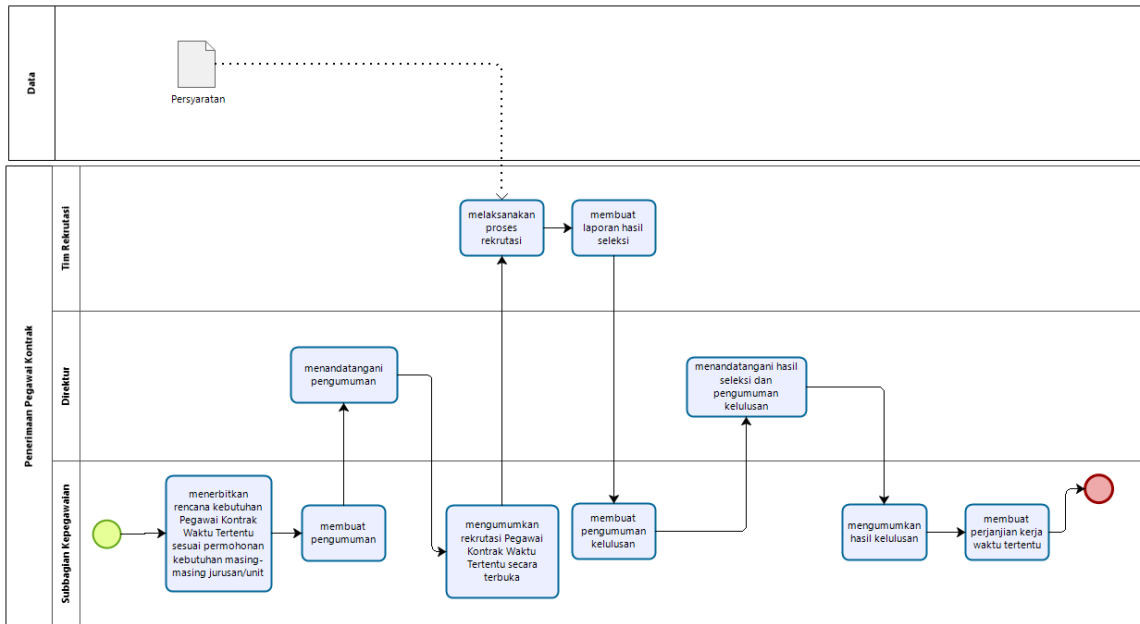

Powered by bizagi Modeler

186. PELAKSANAAN DIKLAT PRAJABATAN CPNS

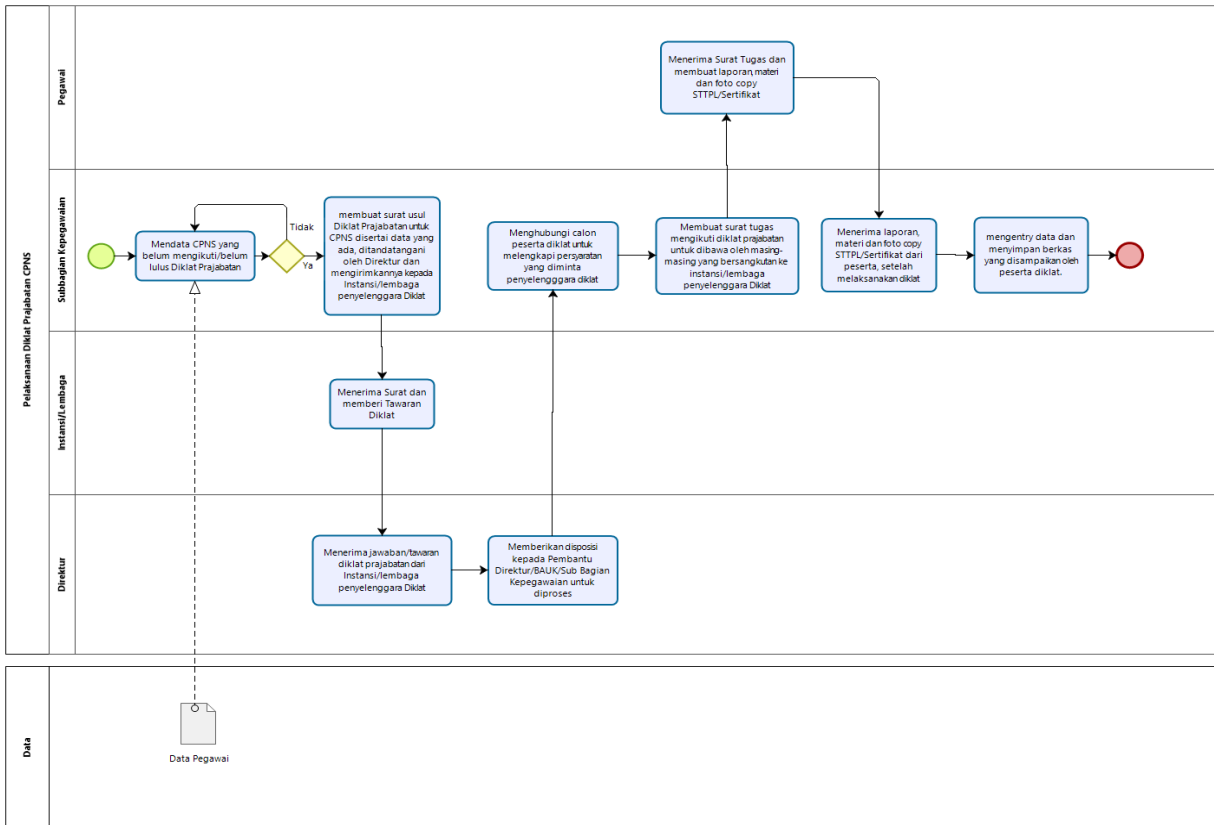

187. PELAKSANAAN PENDIDIKAN DAN PELATIHAN PEGAWAI

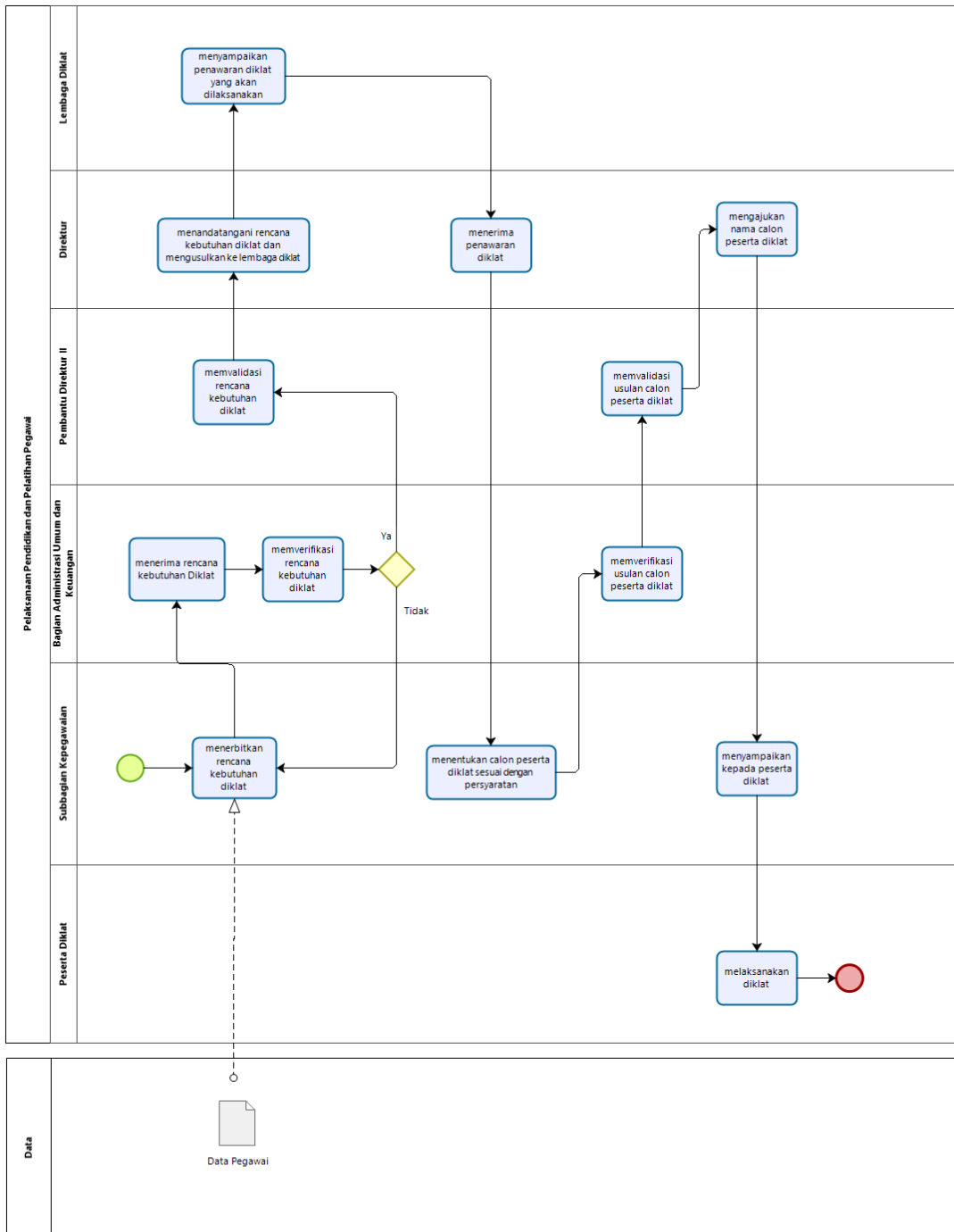

188. PELAKSANAAN DIKLAT

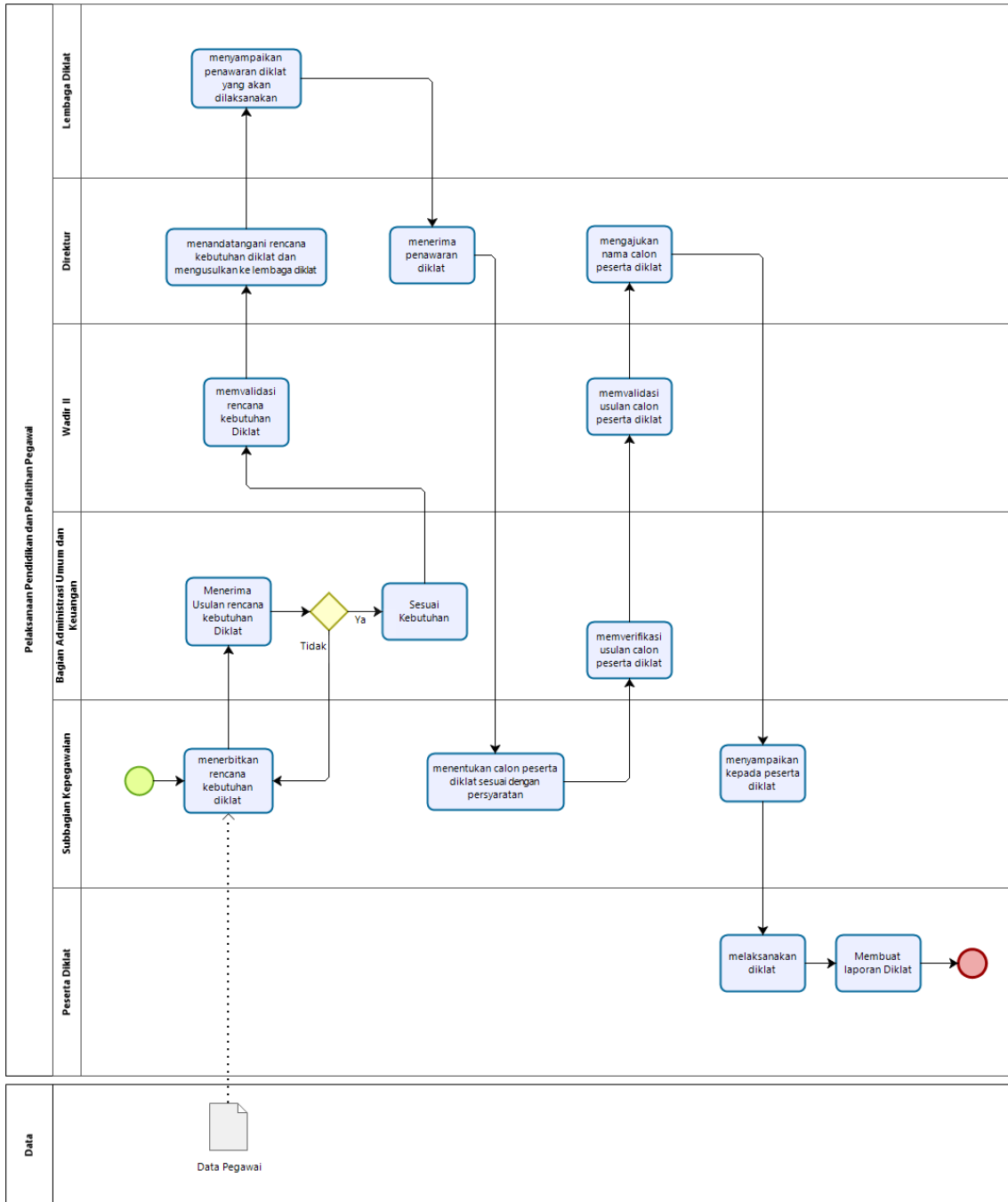

189. PEMBERIAN IZIN BELAJAR

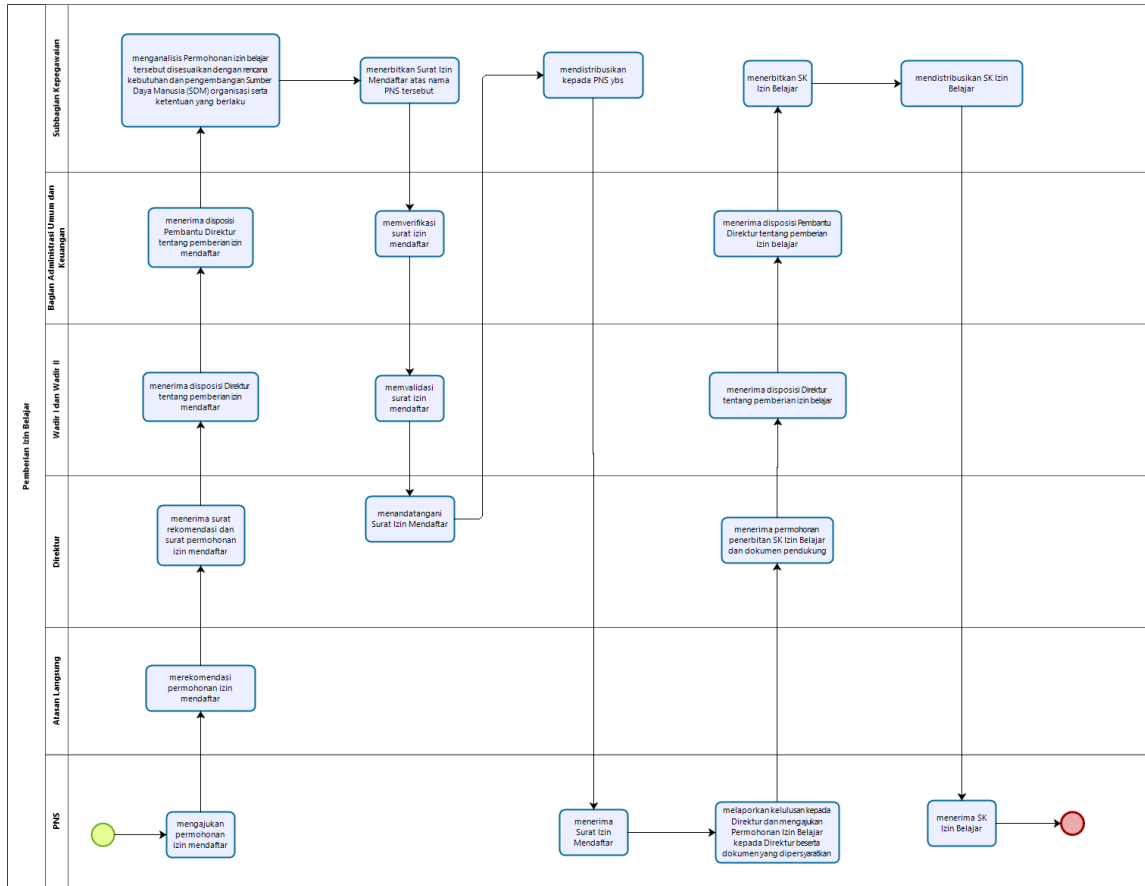

190. PEMBUATAN PERJANJIAN KERJA WAKTU TERTENTU

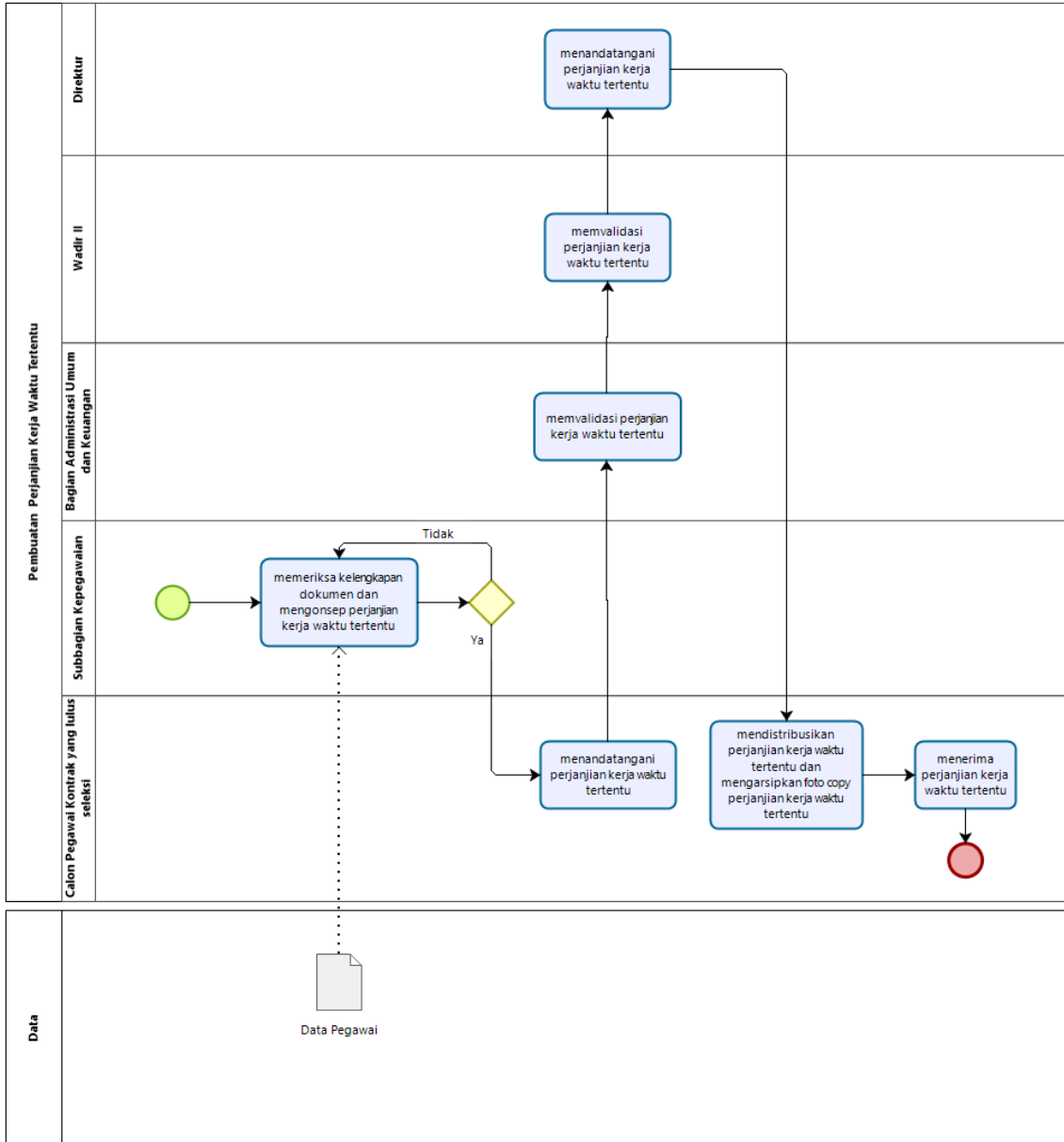

191. PEMBUATAN SURAT KETERANGAN KERJA

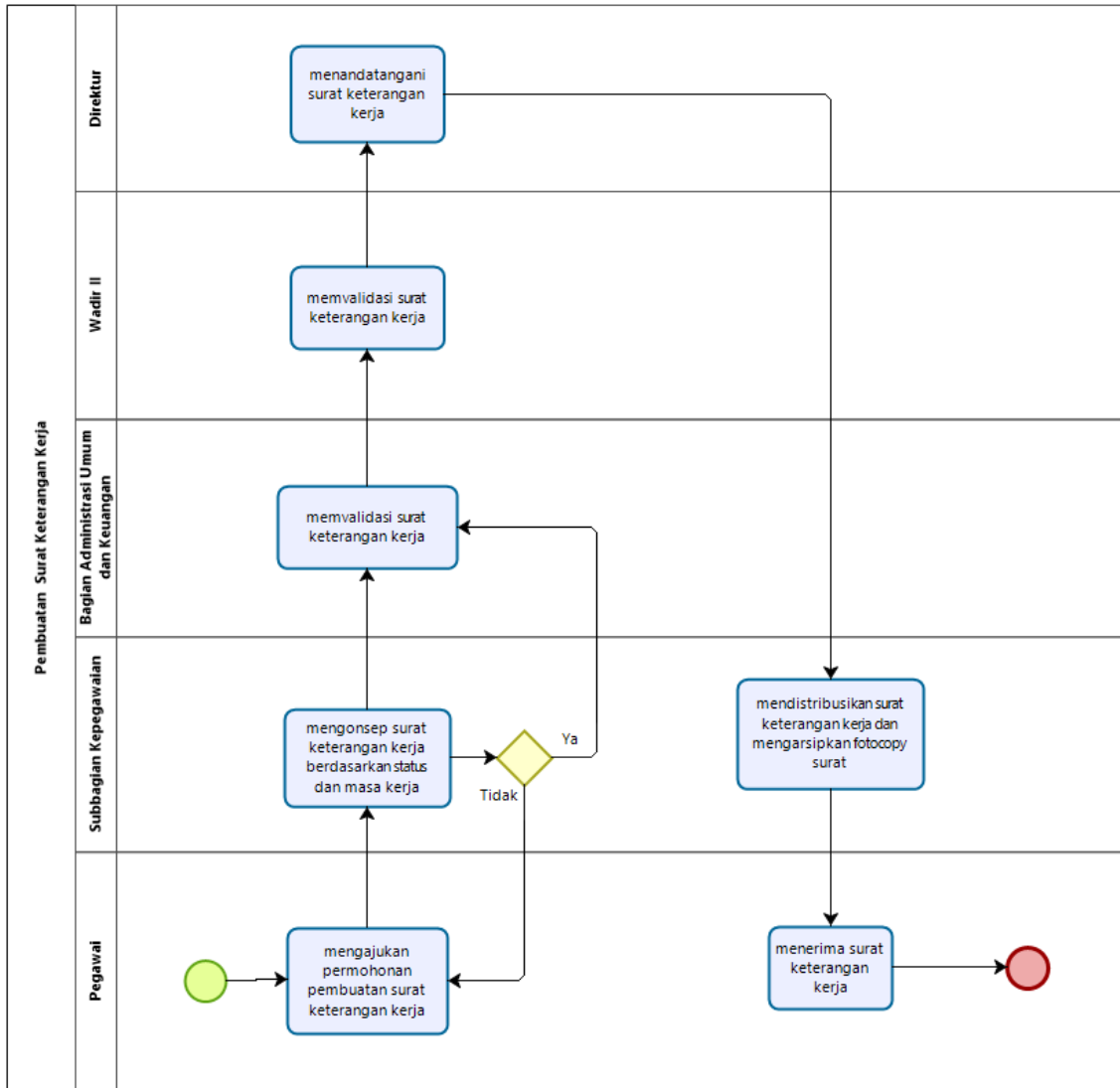

192. PEMBUATAN KARPEG

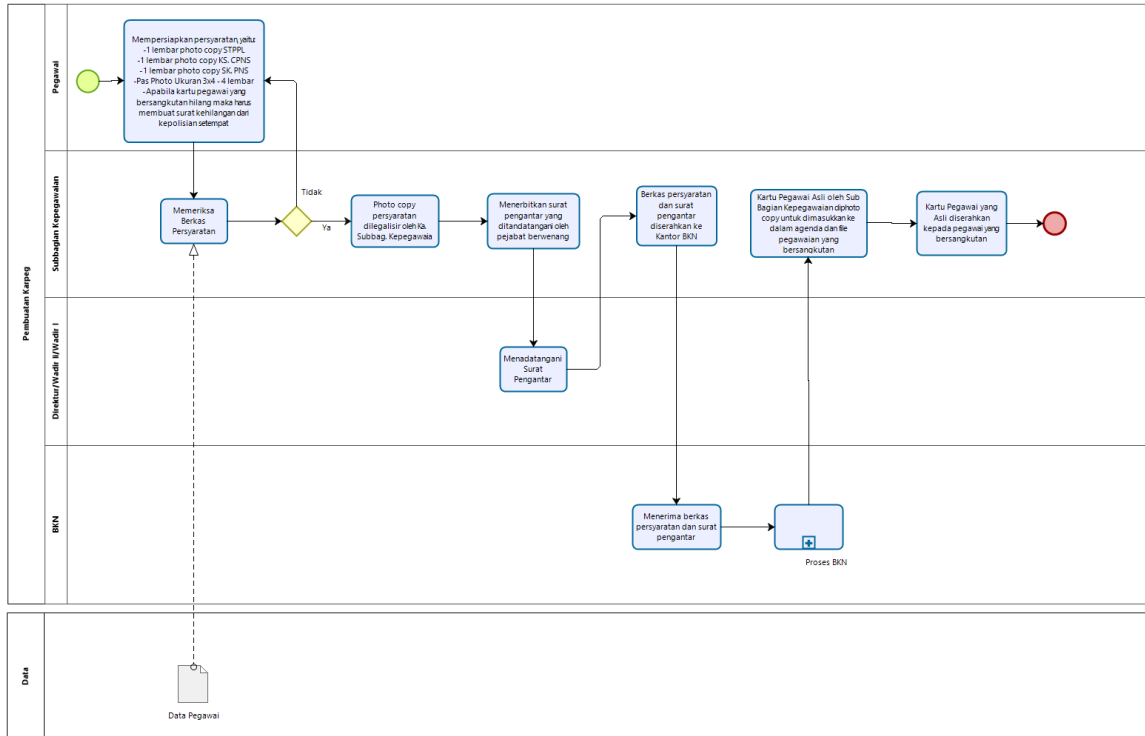

193. PEMBUATAN KARSU/KARIS

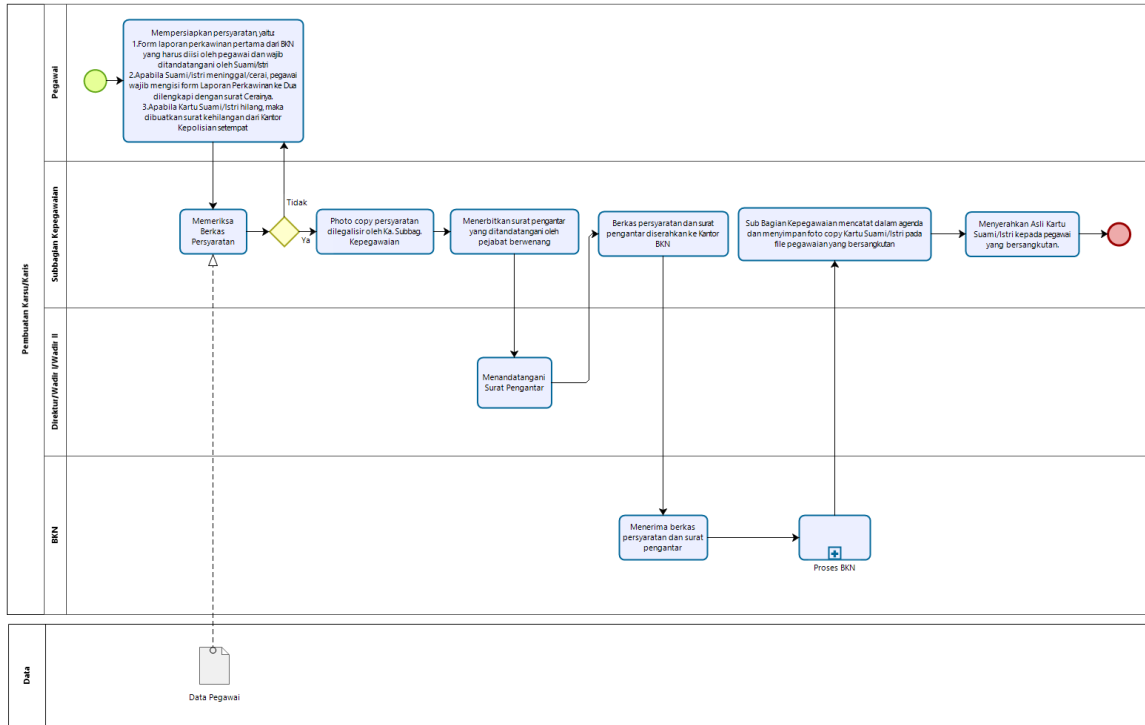

194. PEMBUATAN KARTU INDONESIA SEHAT (KIS)

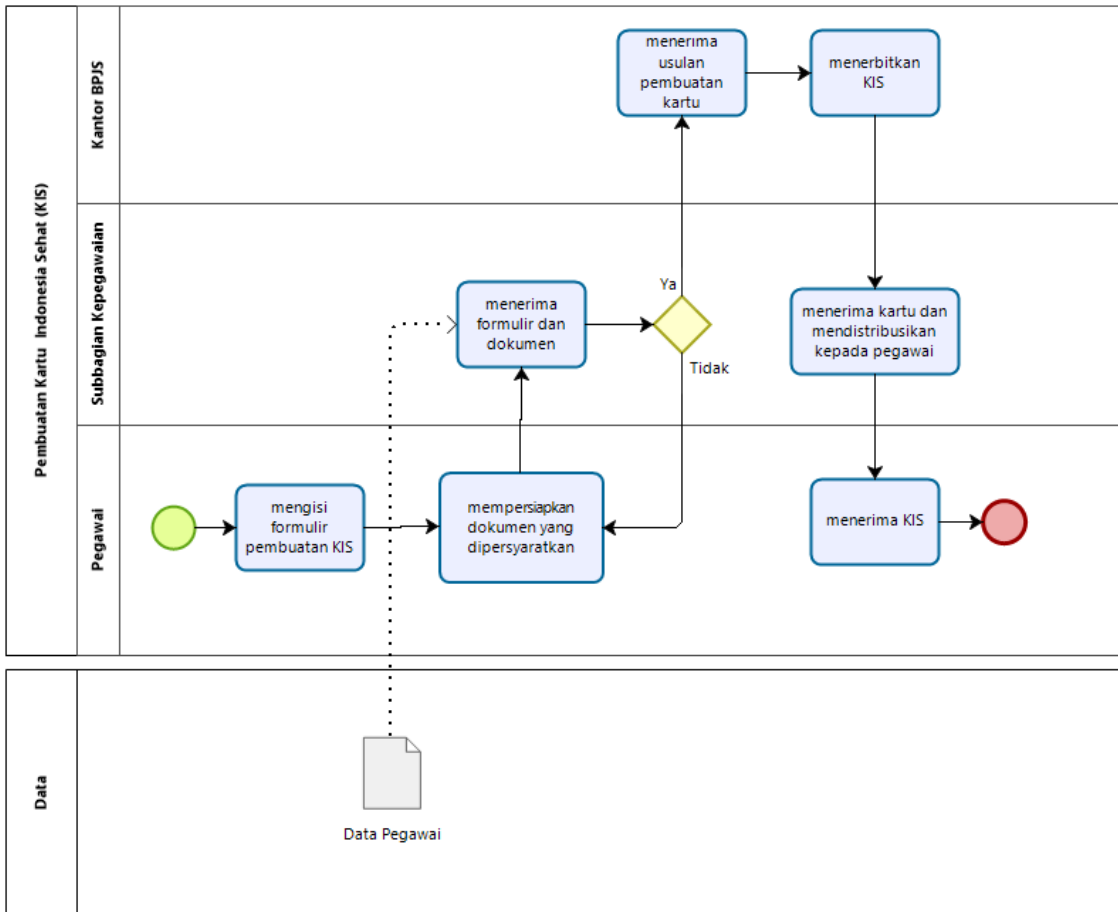

195. PEMBUATAN KARTU PESERTA TASPEN

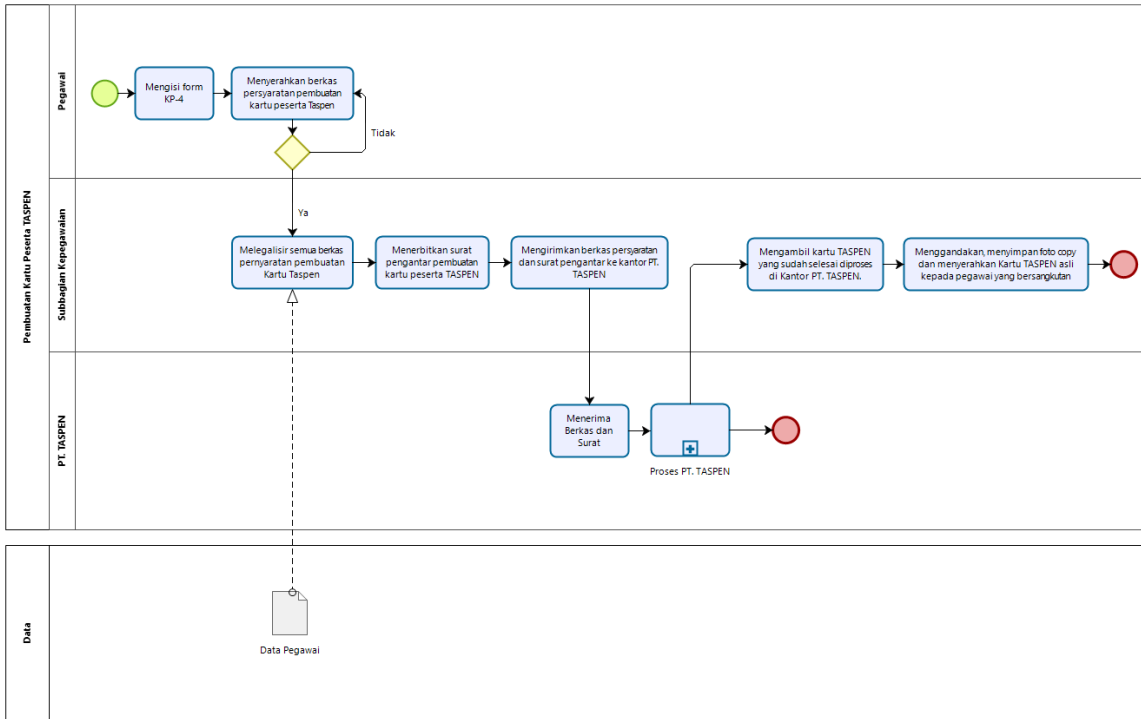

196. PENERBITAN FORMULIR PENILAIAN PRESTASI KERJA CPNS/PNS

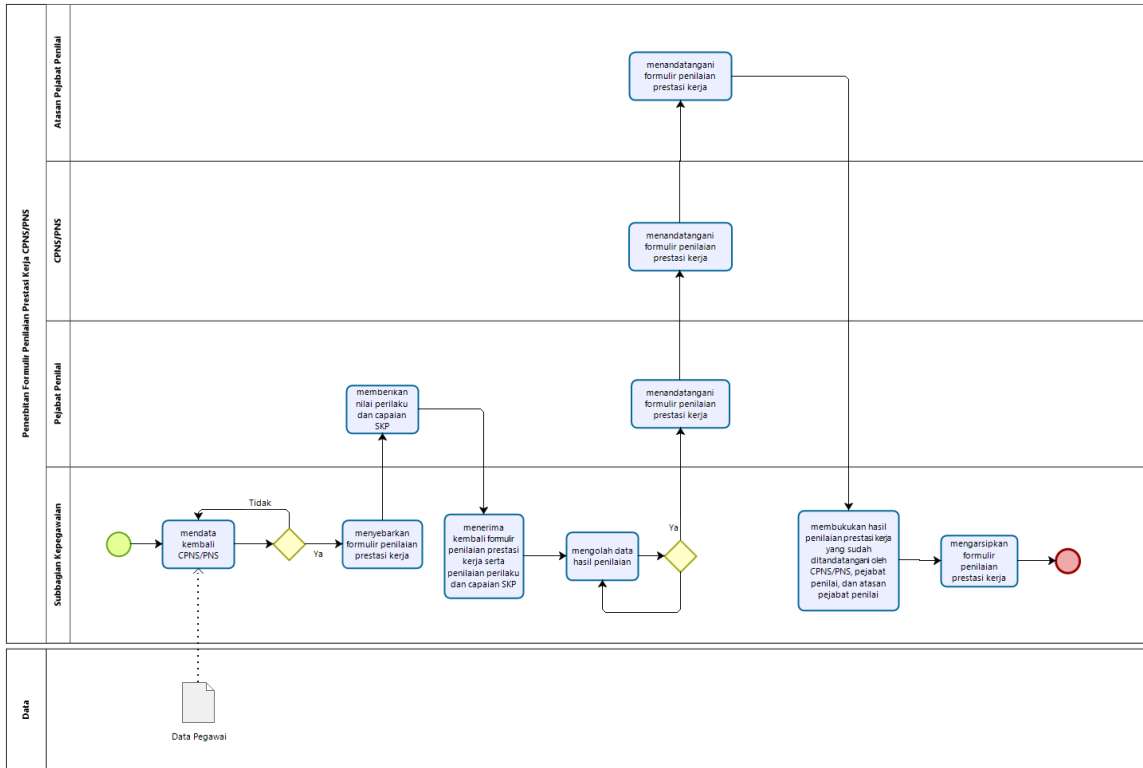

197. PENERBITAN SK KGB

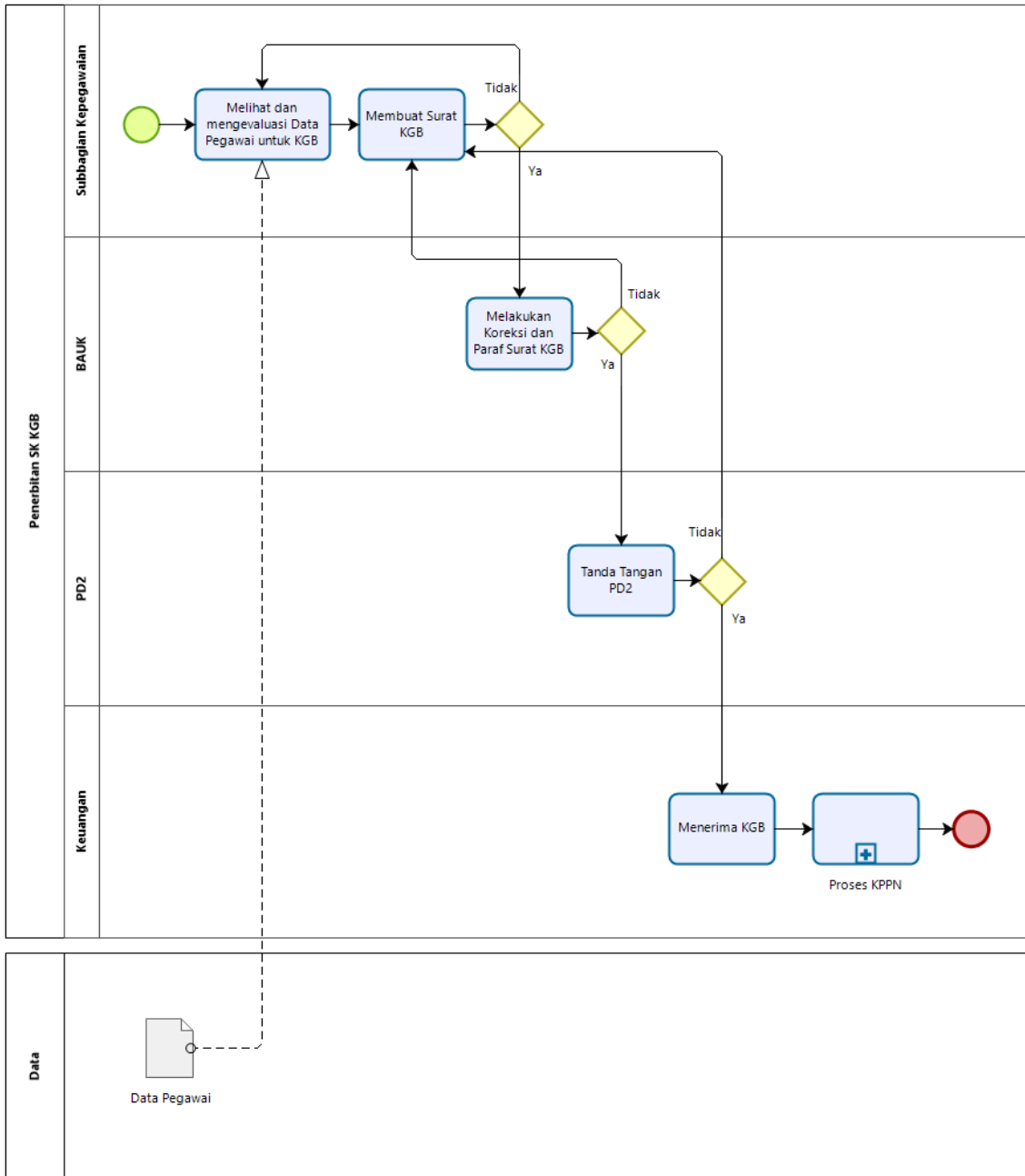

198. PENERBITAN SK KEGIATAN

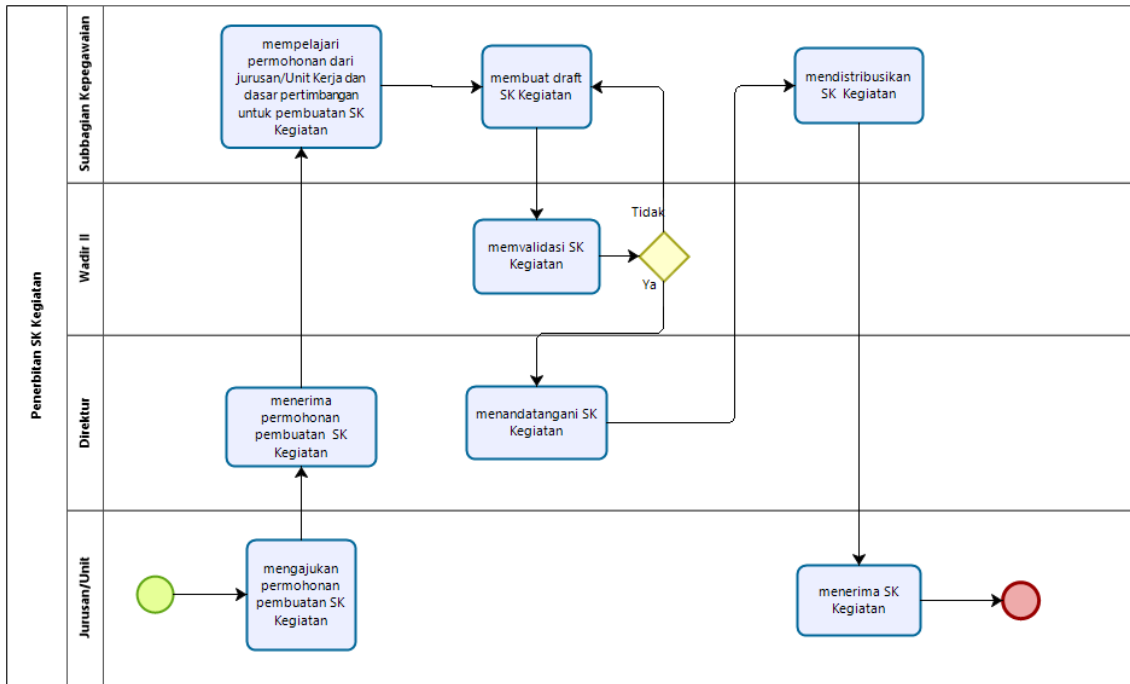

199. PENERBITAN SK PEJABAT STRUKTURAL JURUSAN

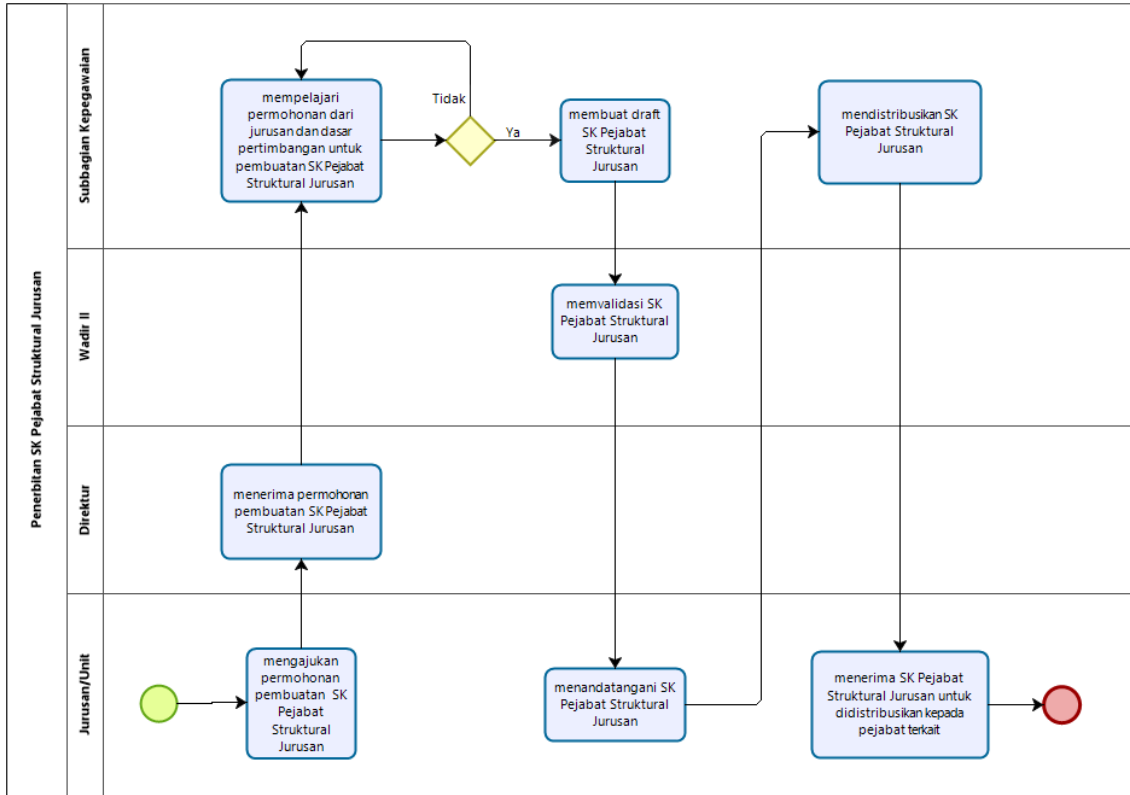

200. PENERBITAN SURAT TUGAS BELAJAR

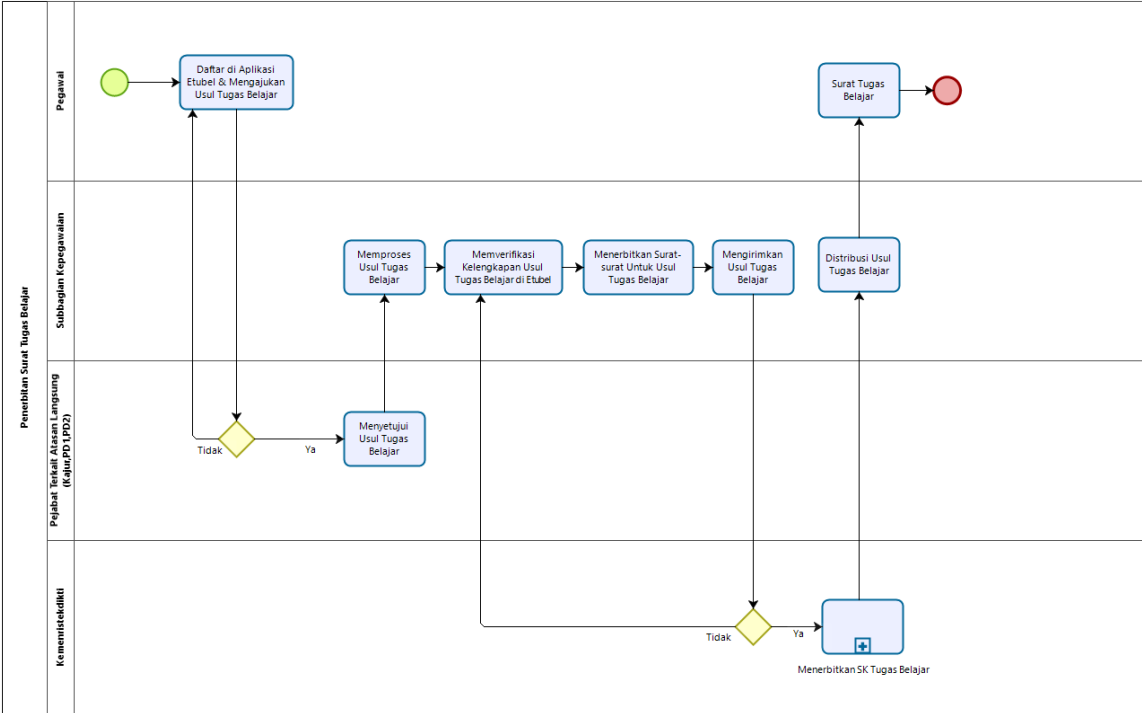

Powered by bizagi Modeler

201. CUTI BERSALIN

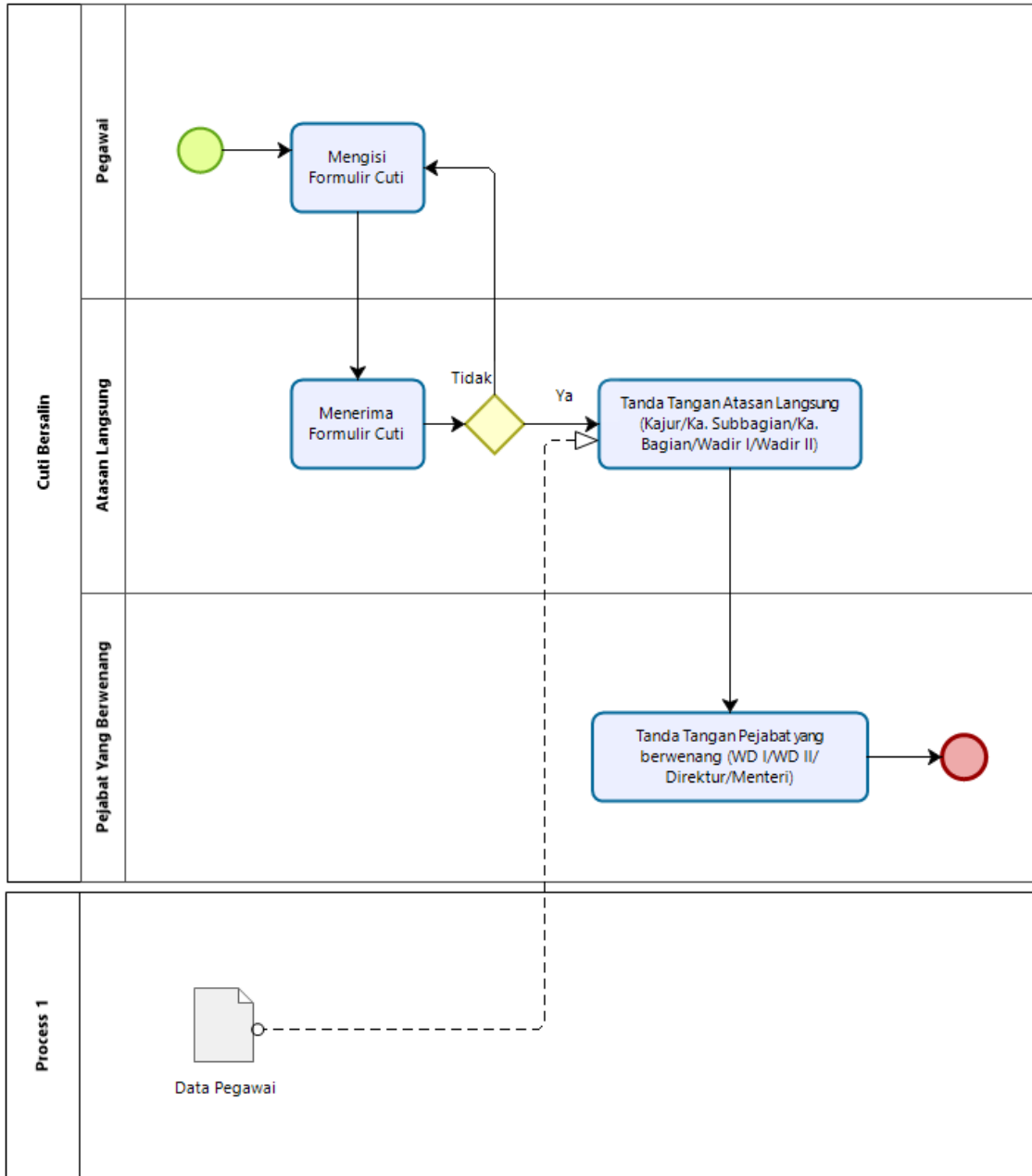

202. CUTI BESAR

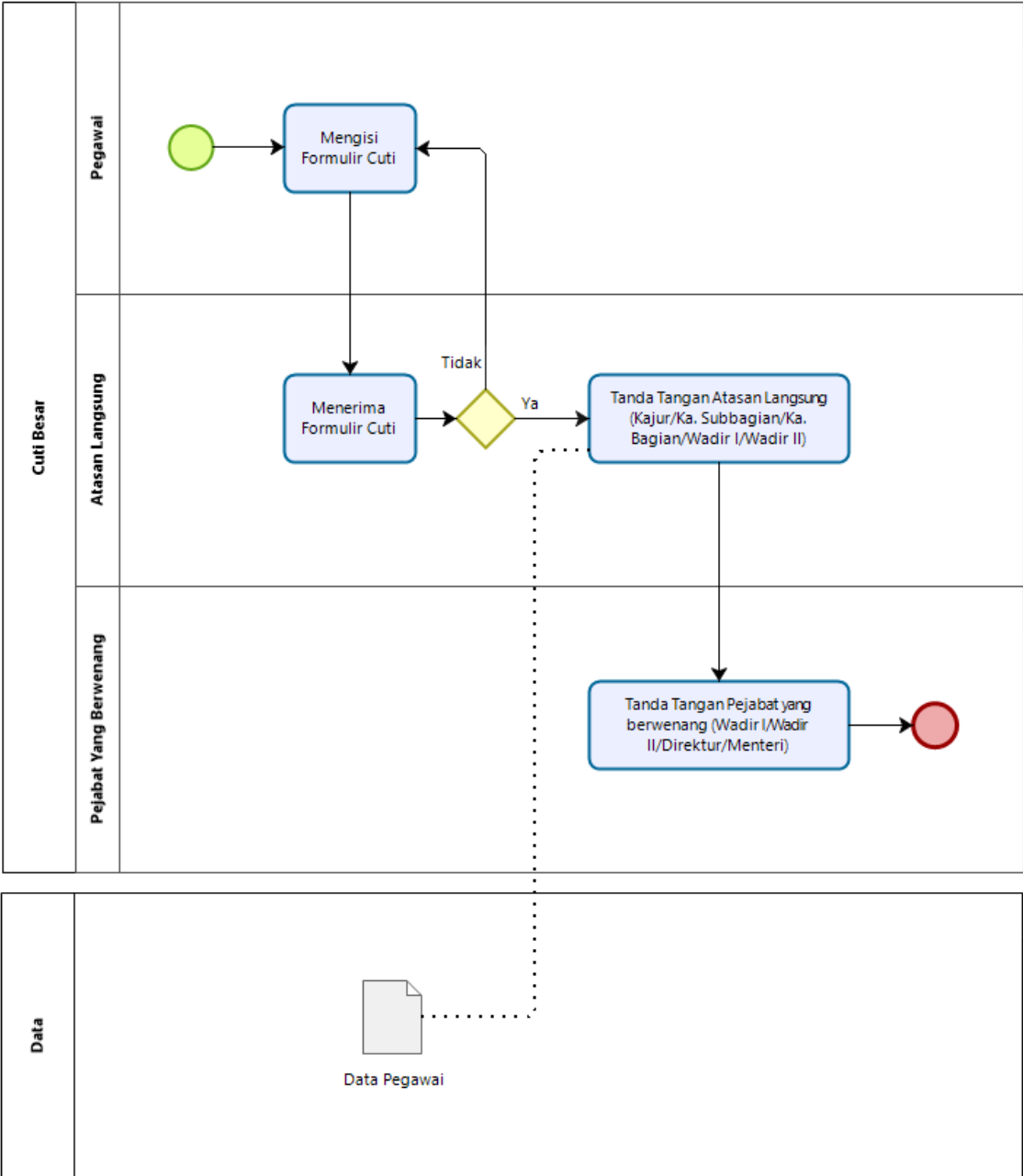

203. CUTI DI LUAR TANGGUNGAN NEGARA

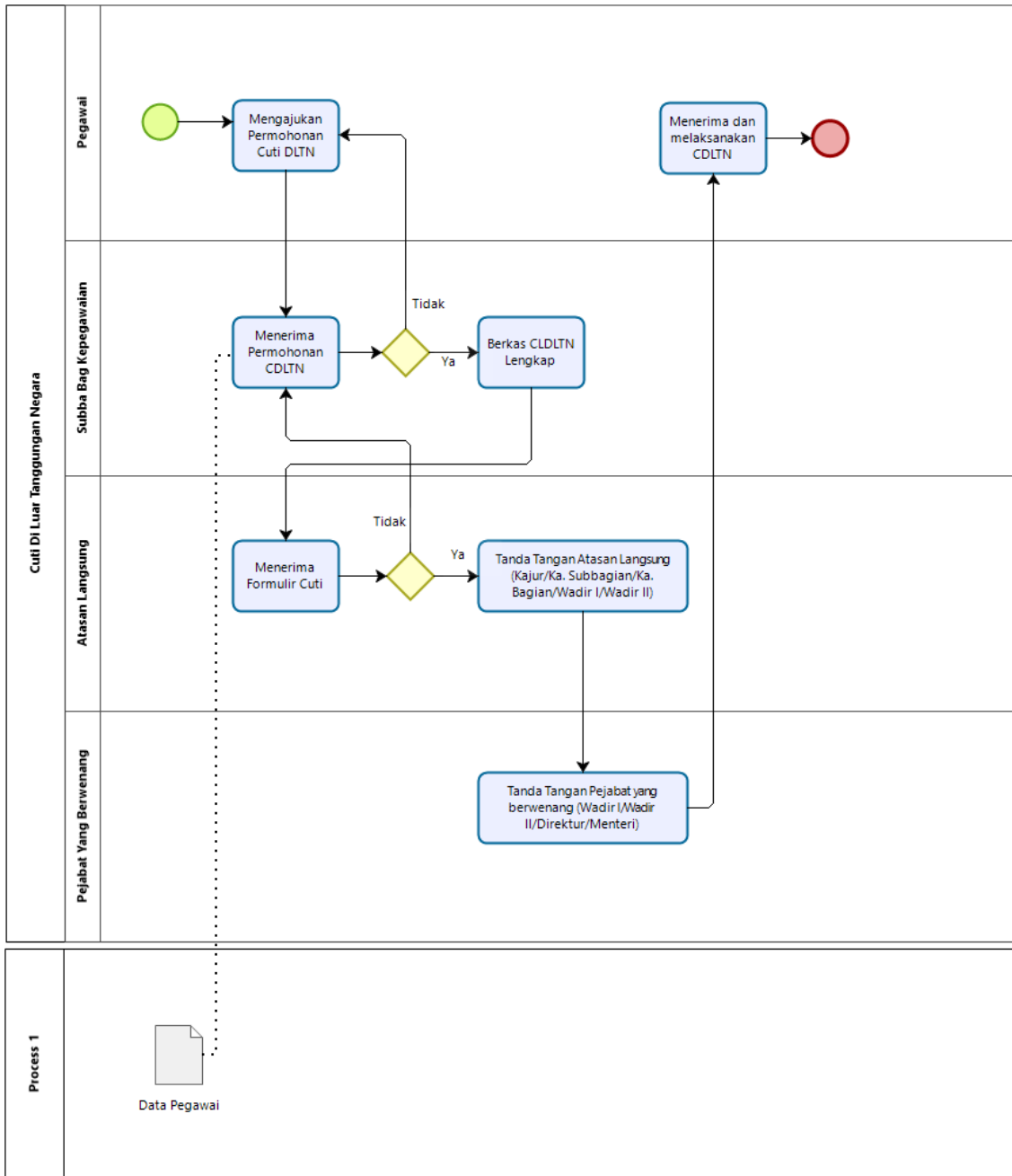

204. CUTI SAKIT

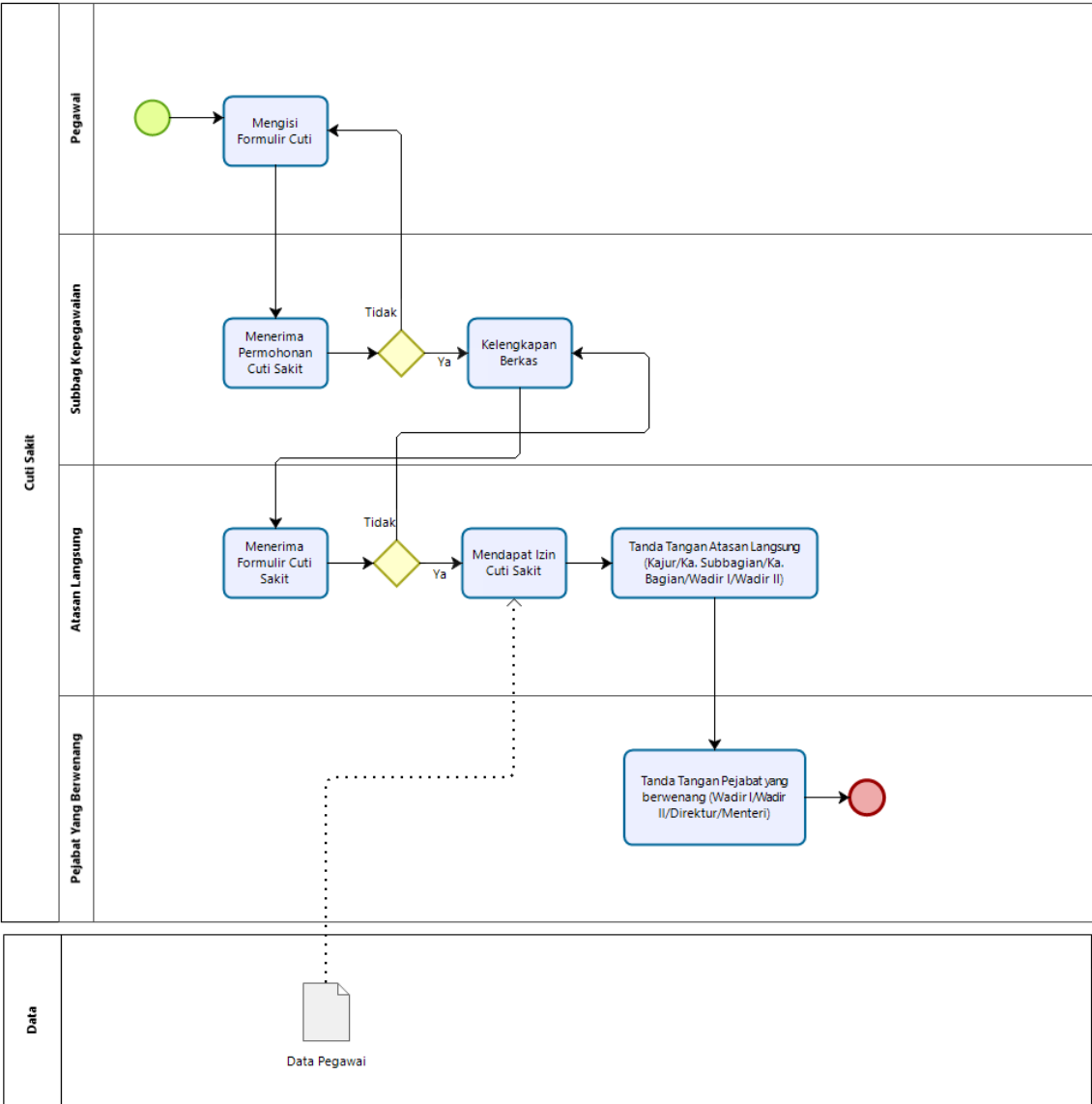

205. CUTI TAHUNAN

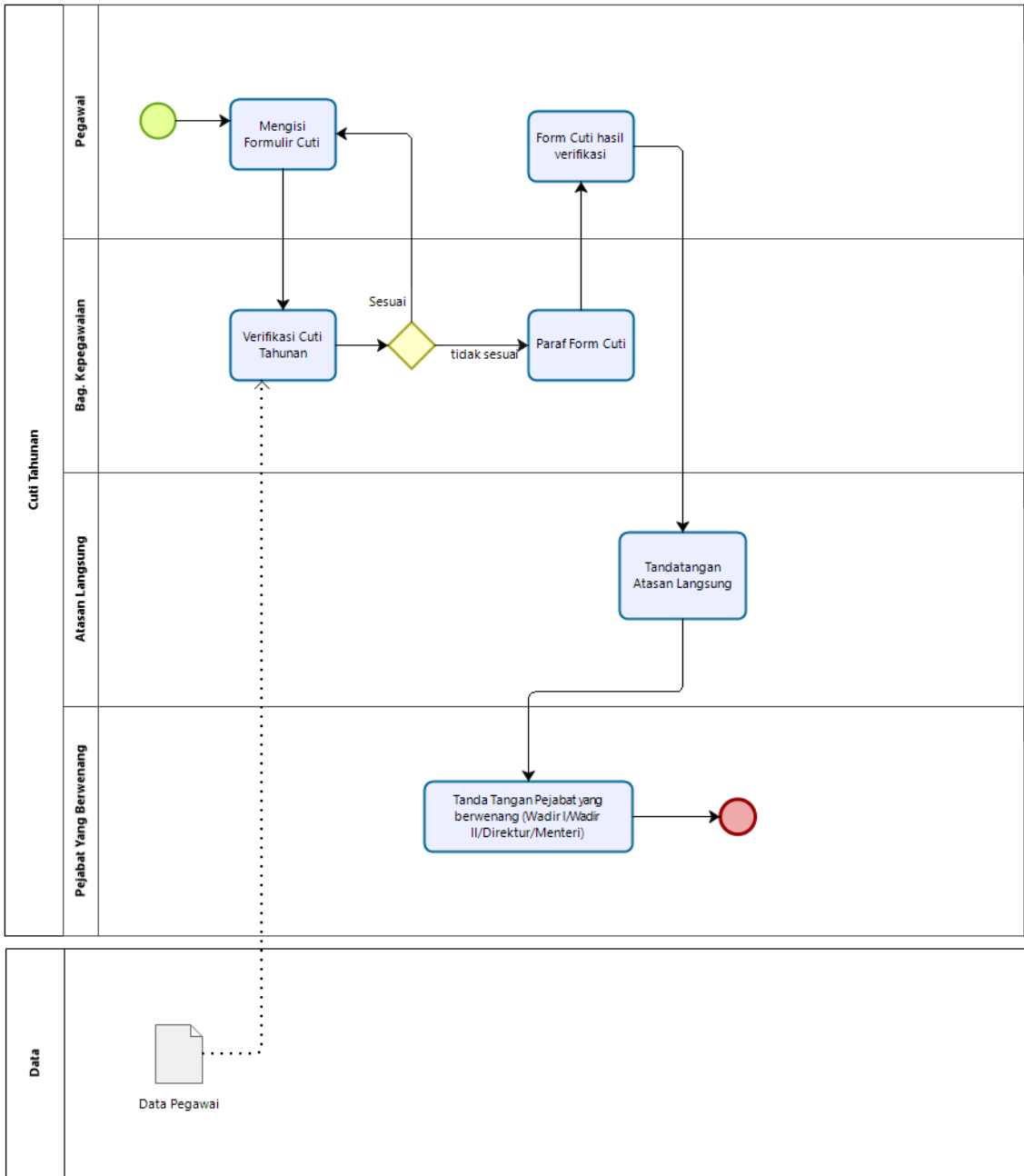

206. PENGAJUAN TUNJANGAN KELUARGA (KP-4)

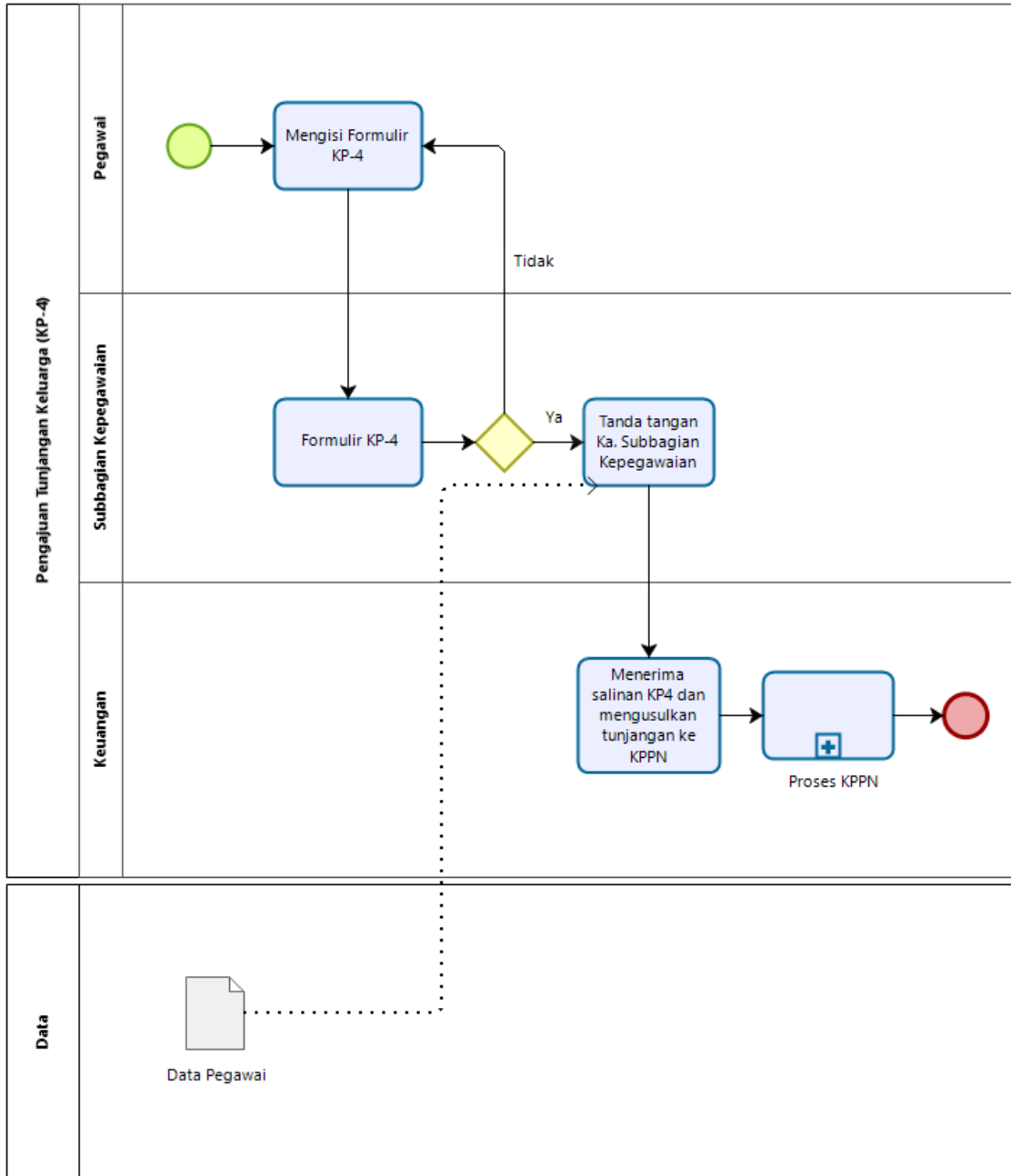

207. PENGANGKATAN CPNS MENJADI PNS

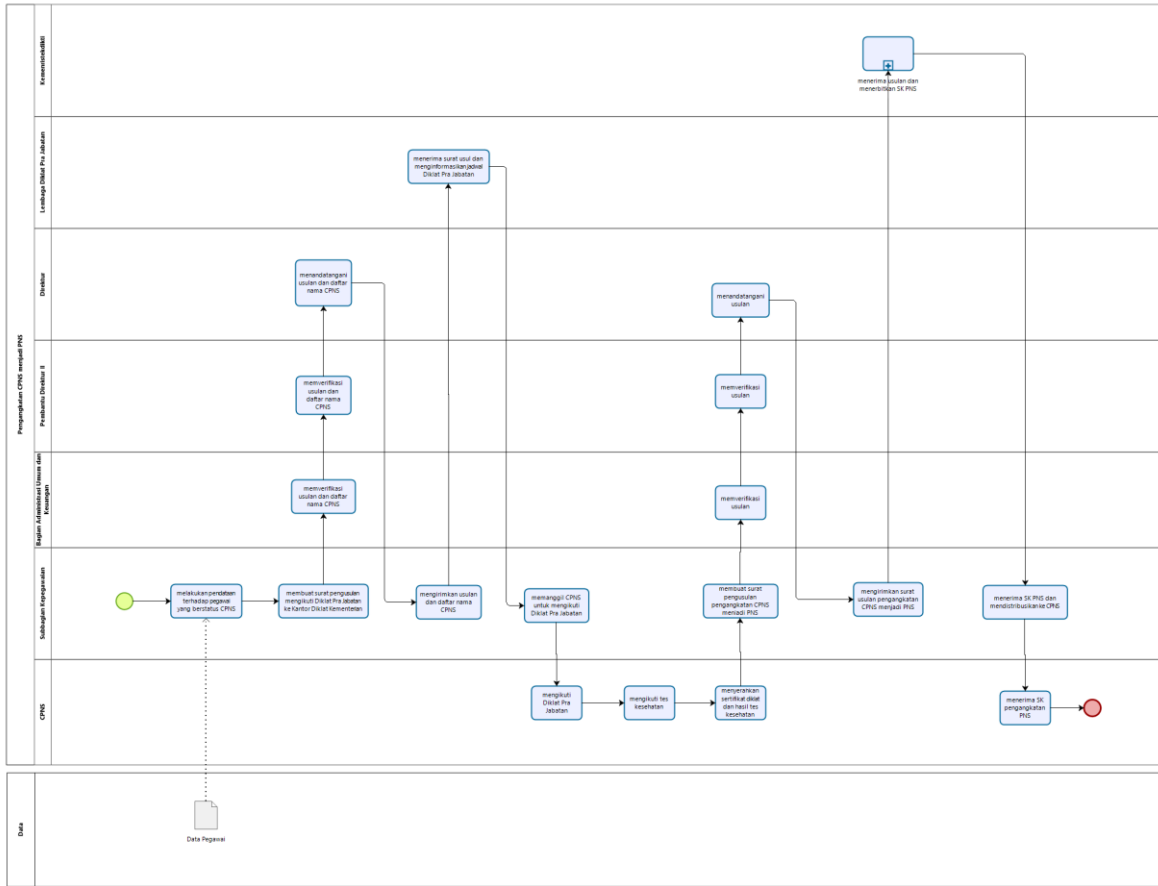

208. PENSIUN PNS KARENA MENCAPAI BUP (NORMAL)

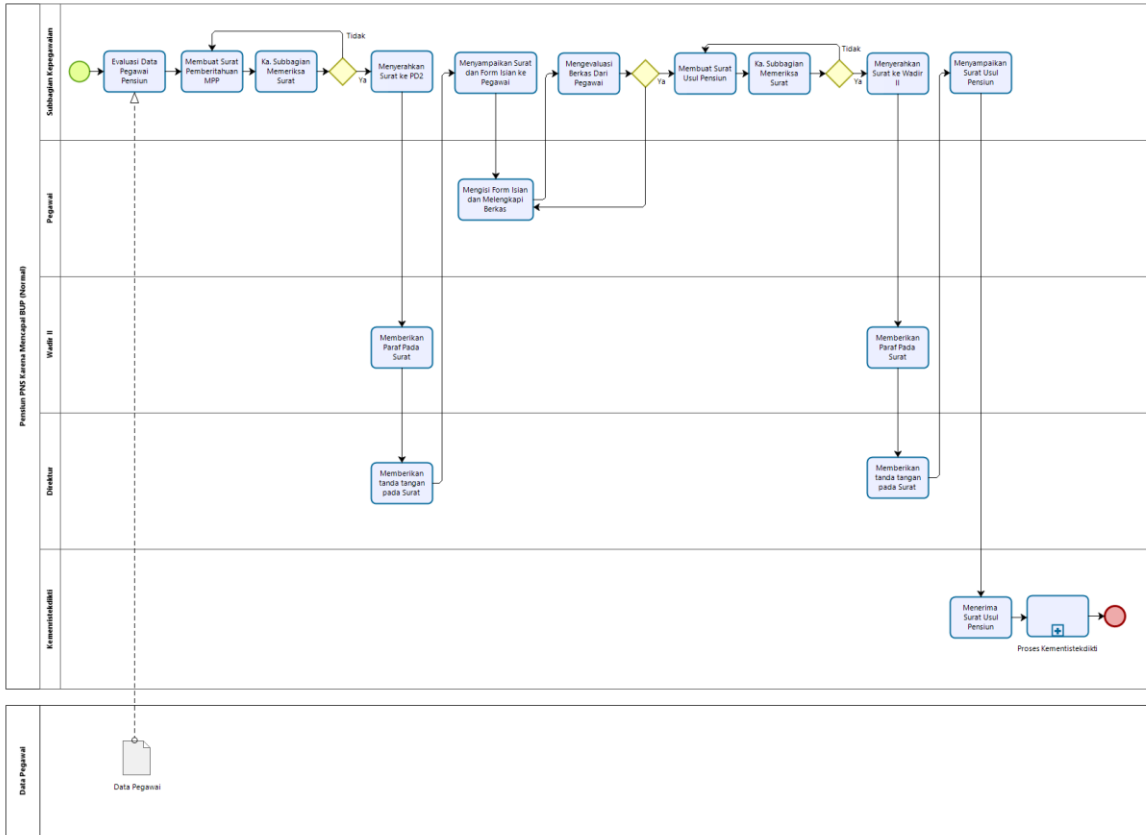

209. PENSIUN DINI PNS

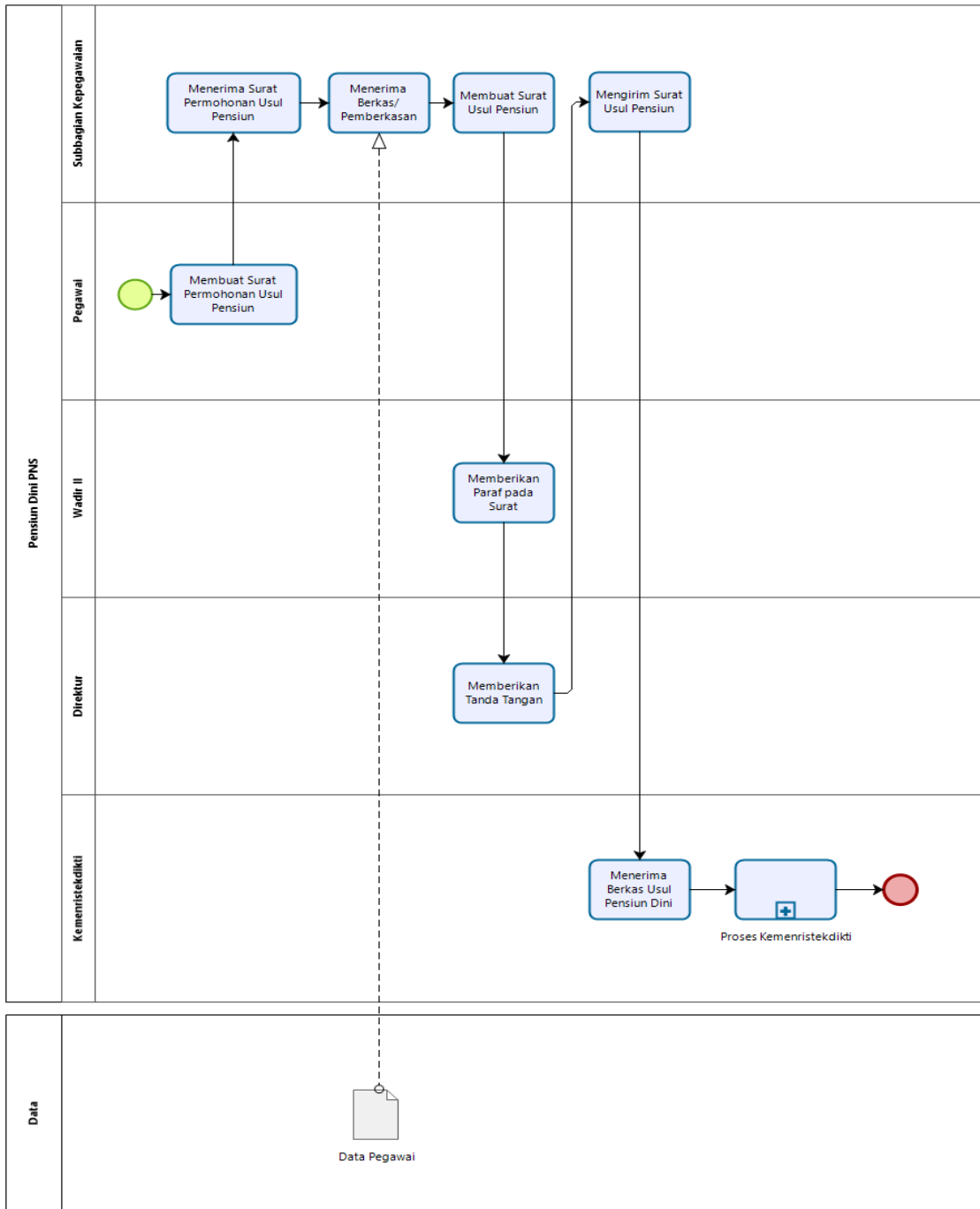

210. Pensiun PNS KARENA MENINGGAL DUNIA

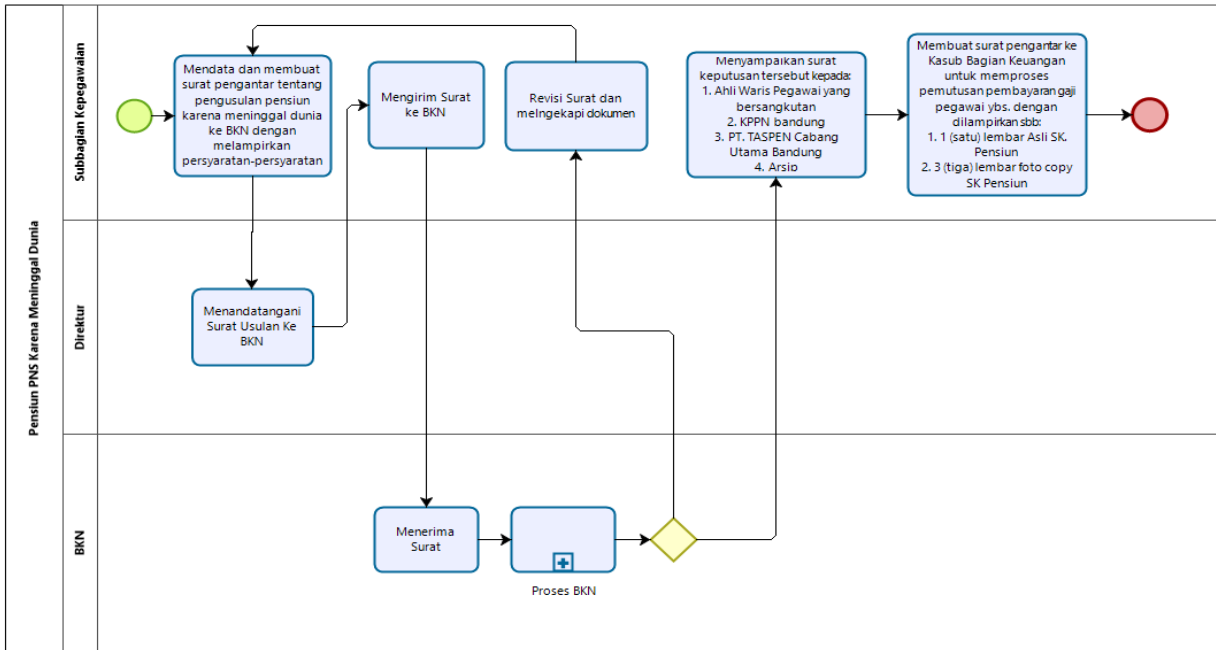

211. PENSIUN PNS KARENA SAKIT (KEUZURAN)

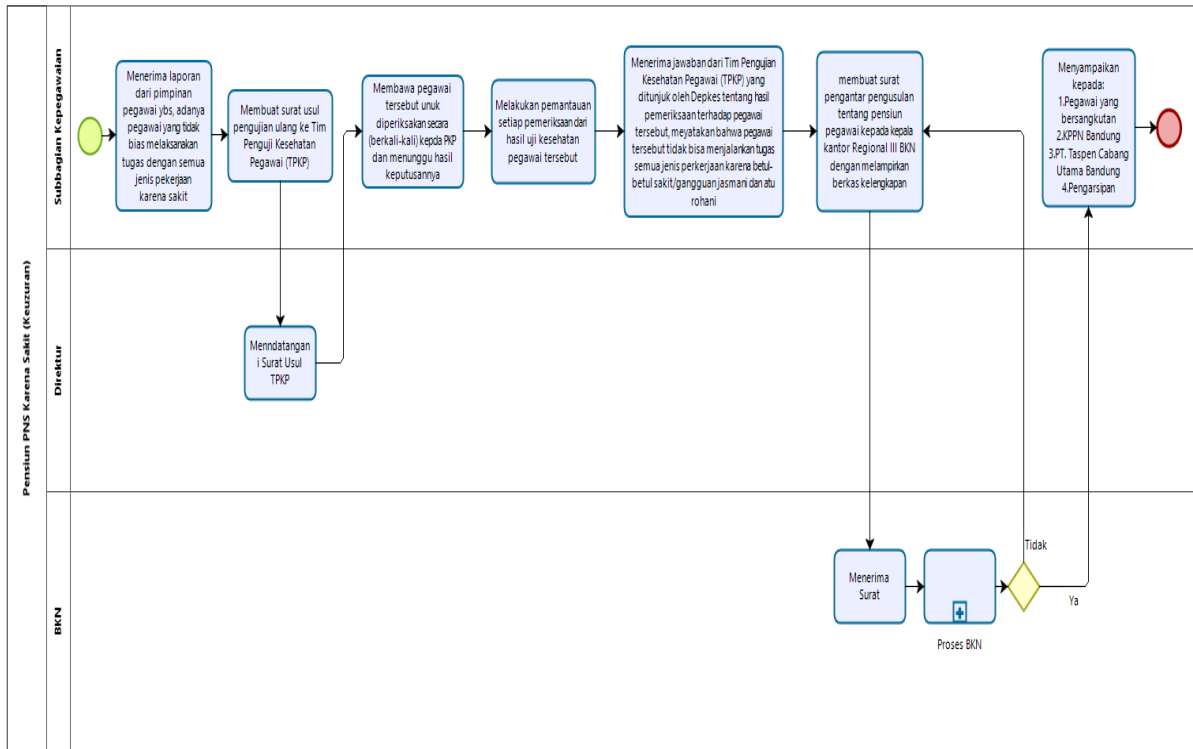

212. PENYUSUNAN FORMASI CPNS

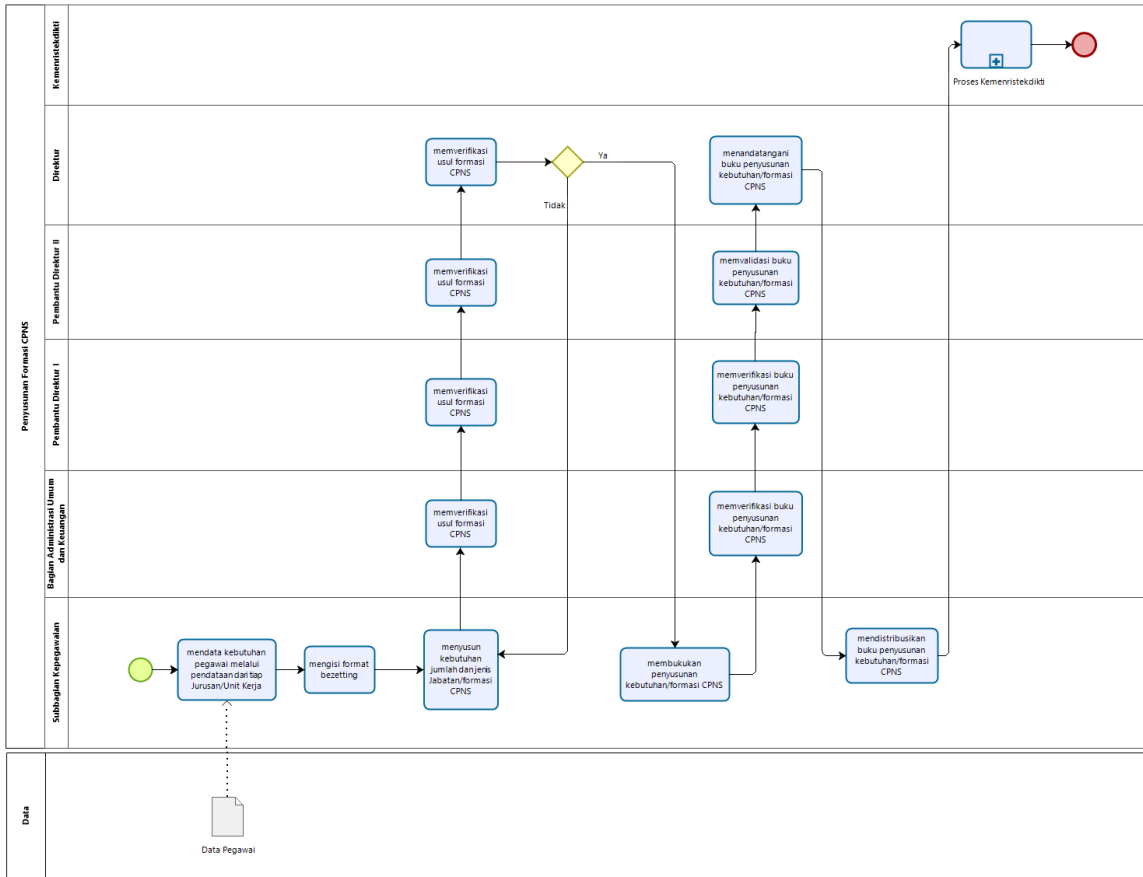

213. ROTASI TENAGA KEPENDIDIKAN

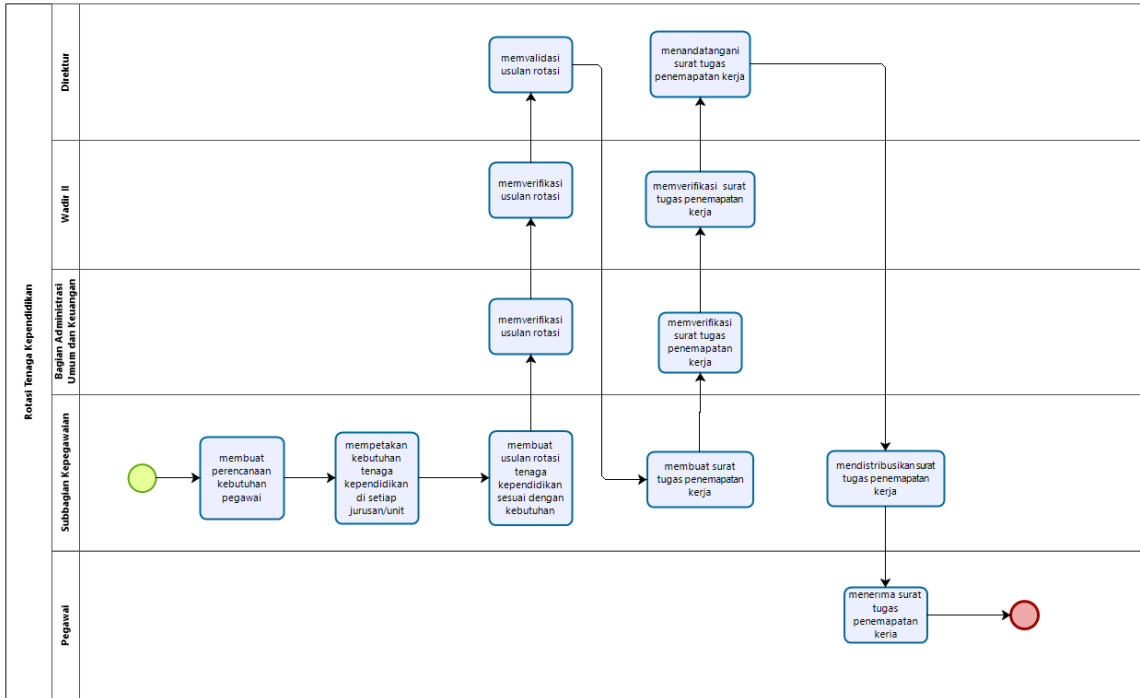

214. USUL ALIH STATUS MENJADI DOSEN

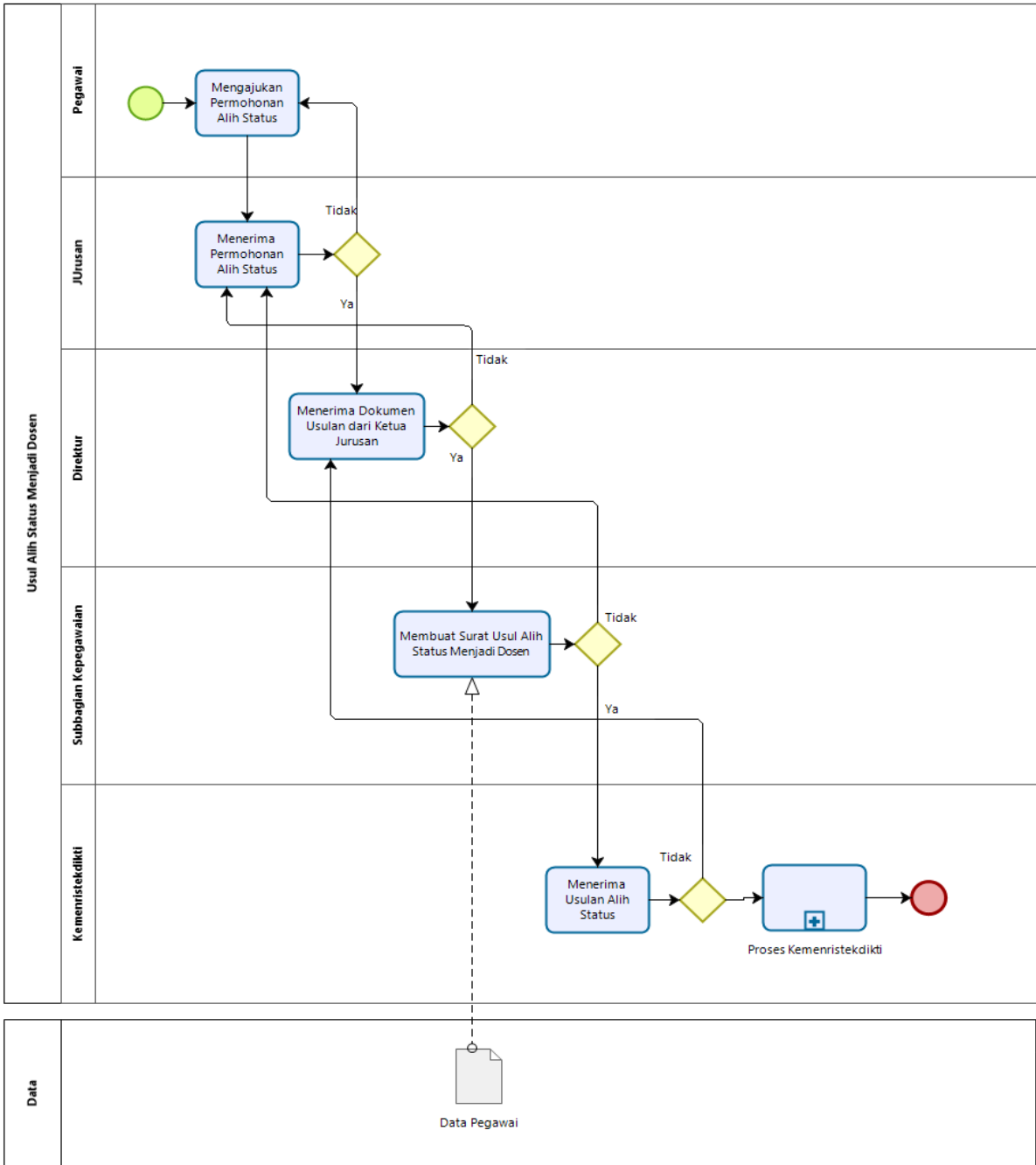

215. USUL PEMBERHENTIAN DENGAN HORMAT

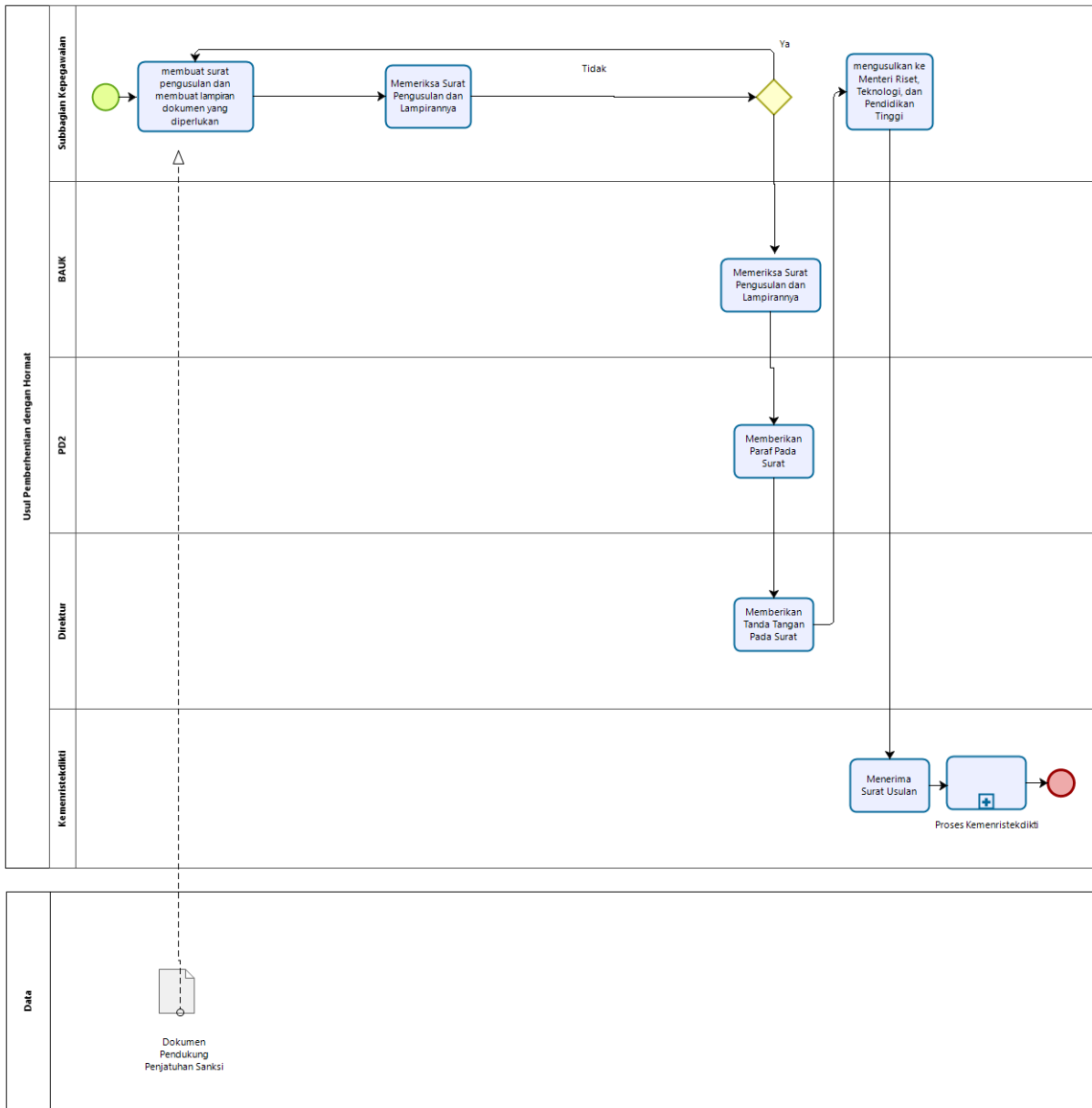

216. USUL STATUS MENJADI DOSEN

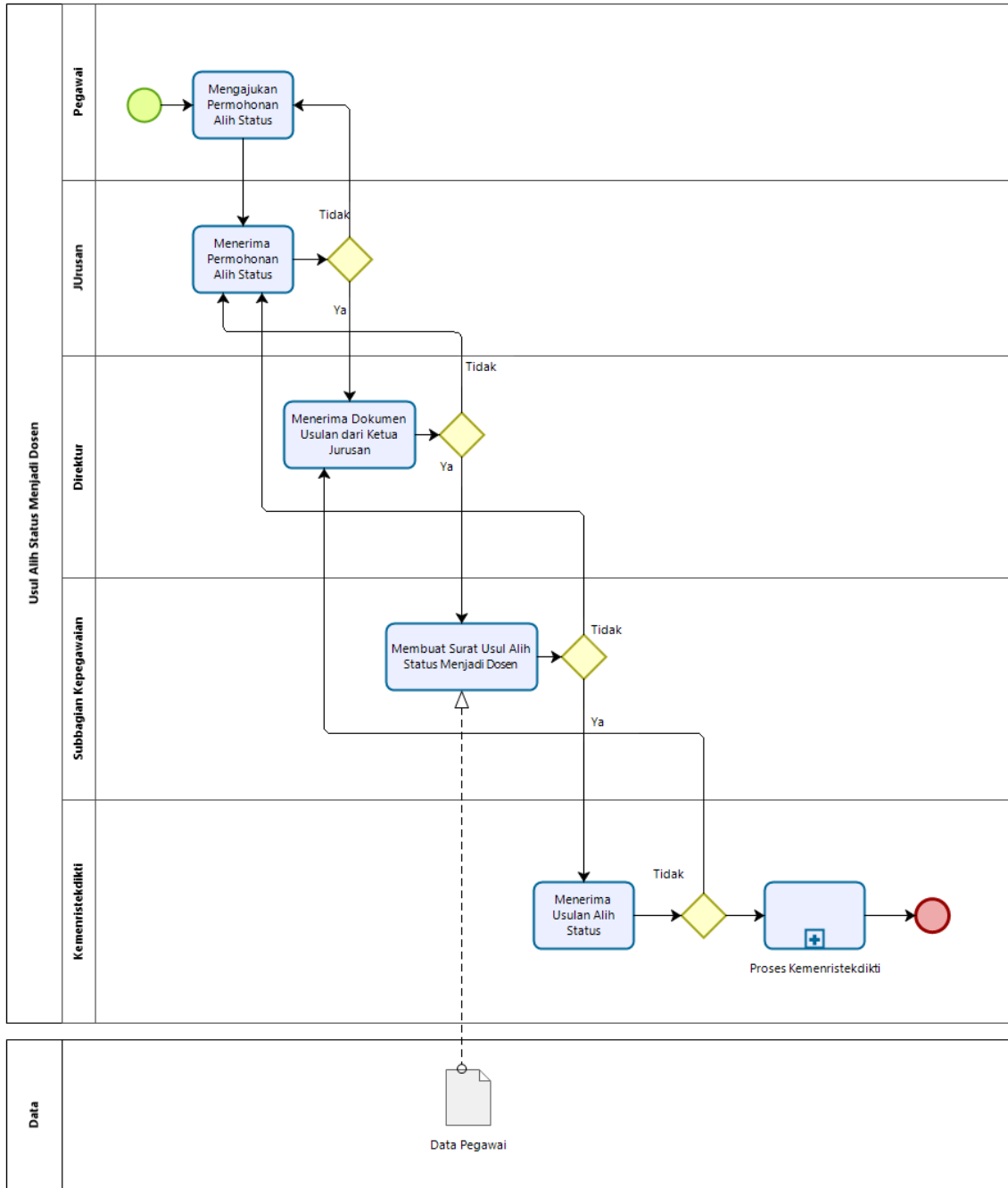

217. USULAN SURAT TUGAS BELAJAR

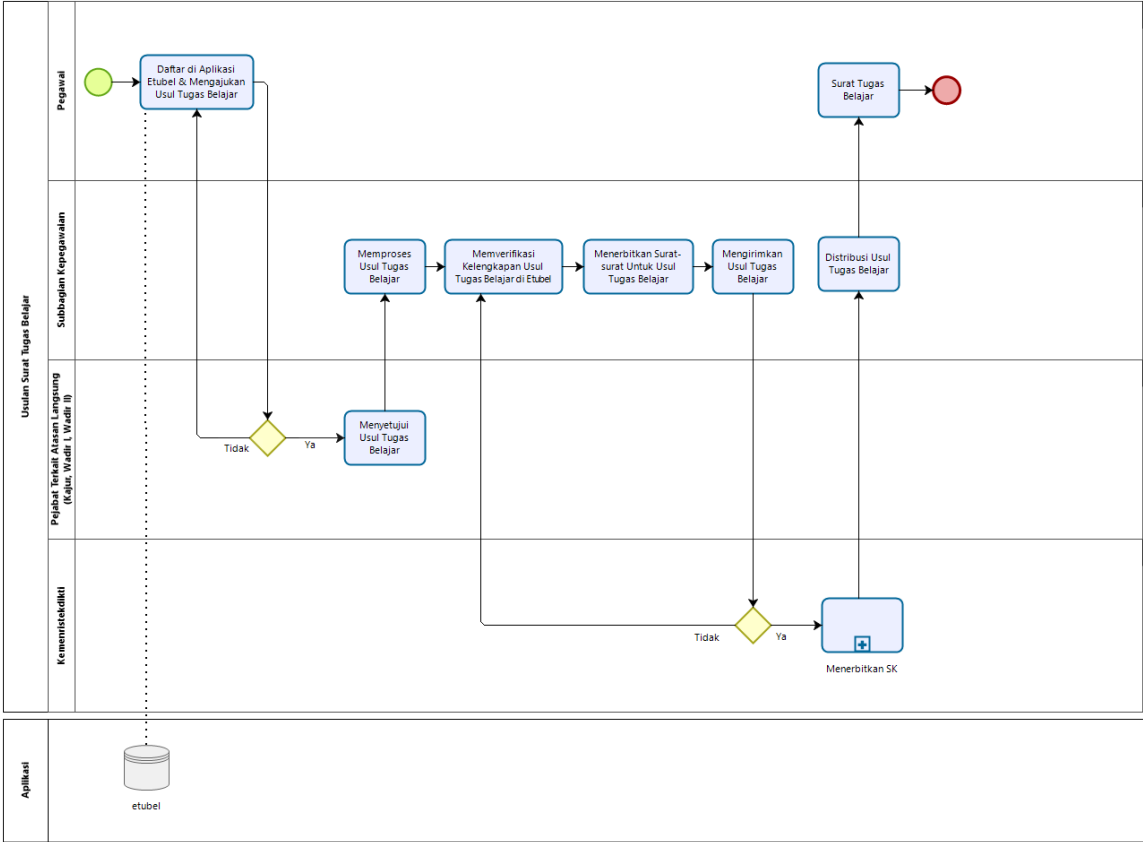

218. PENGUSULAN PENGHARGAAN SATYALANCANA KARYA SATYA

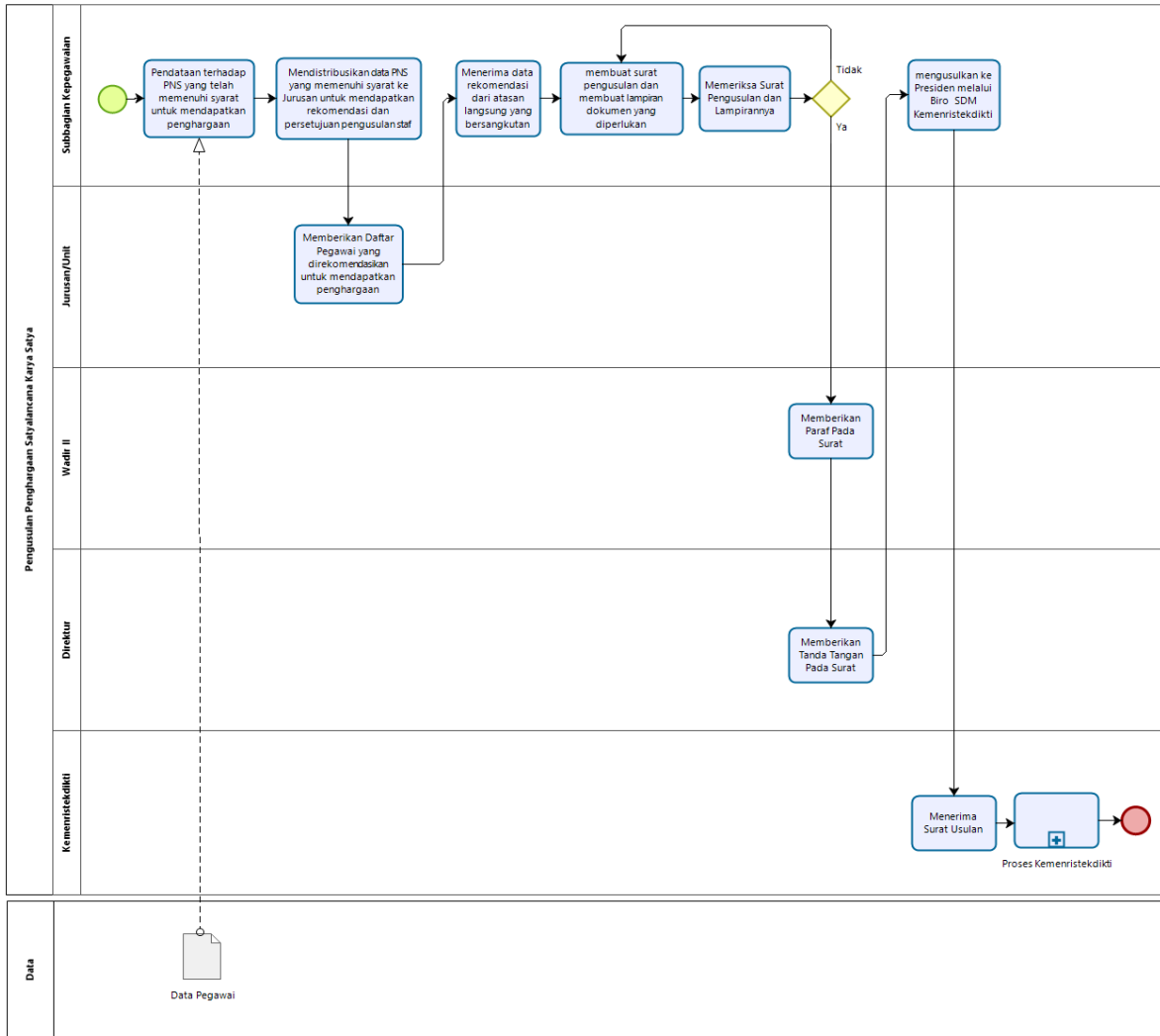

219. PENILAIAN ANGKA KREDIT JAB FUNG DOSEN

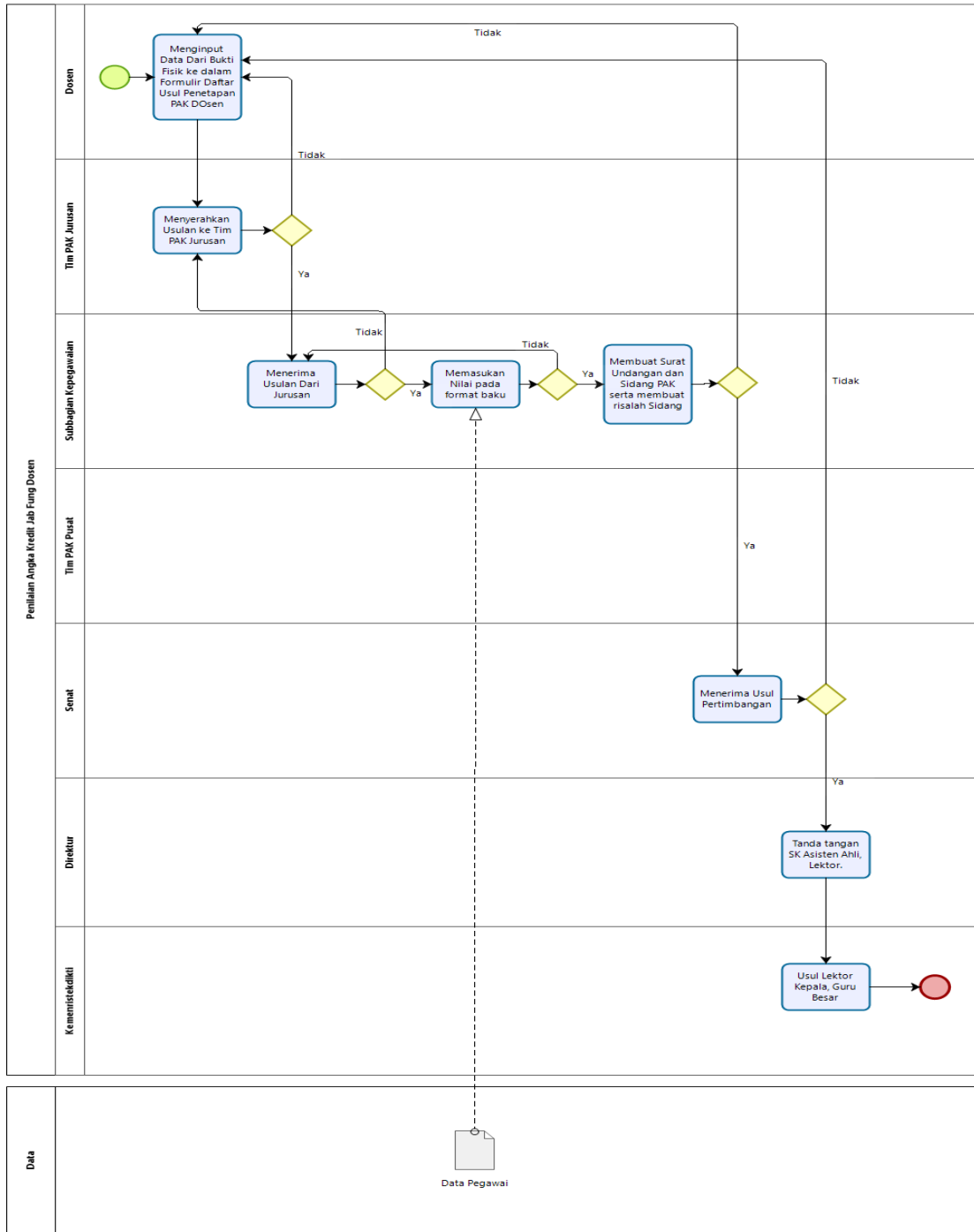

220. PENILAIAN ANGKA KREDIT JABATAN FUNGSIONAL DOSEN

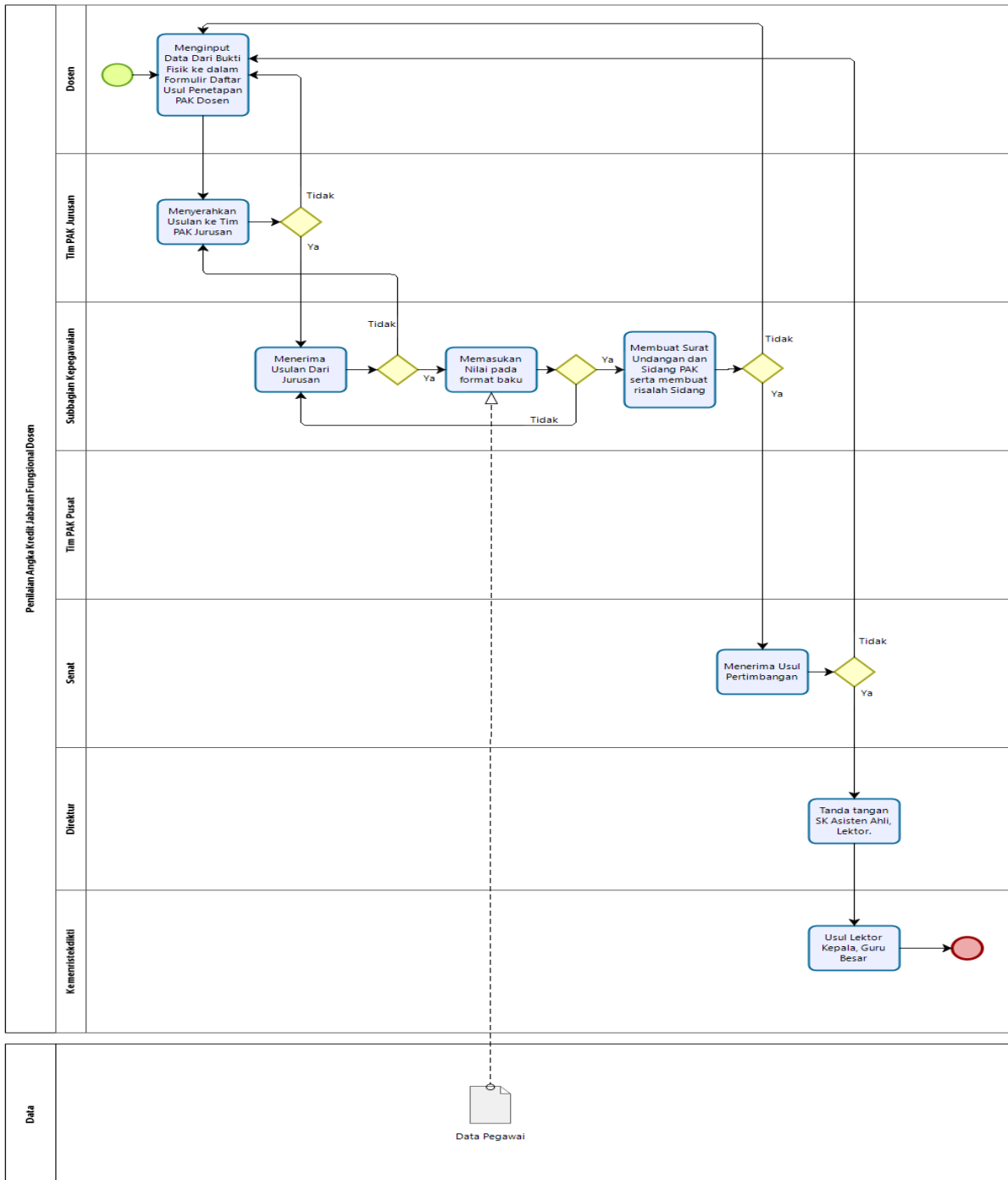

221. PENILAIAN ANGKA KREDIT JABATAN FUNGSIONAL PLP

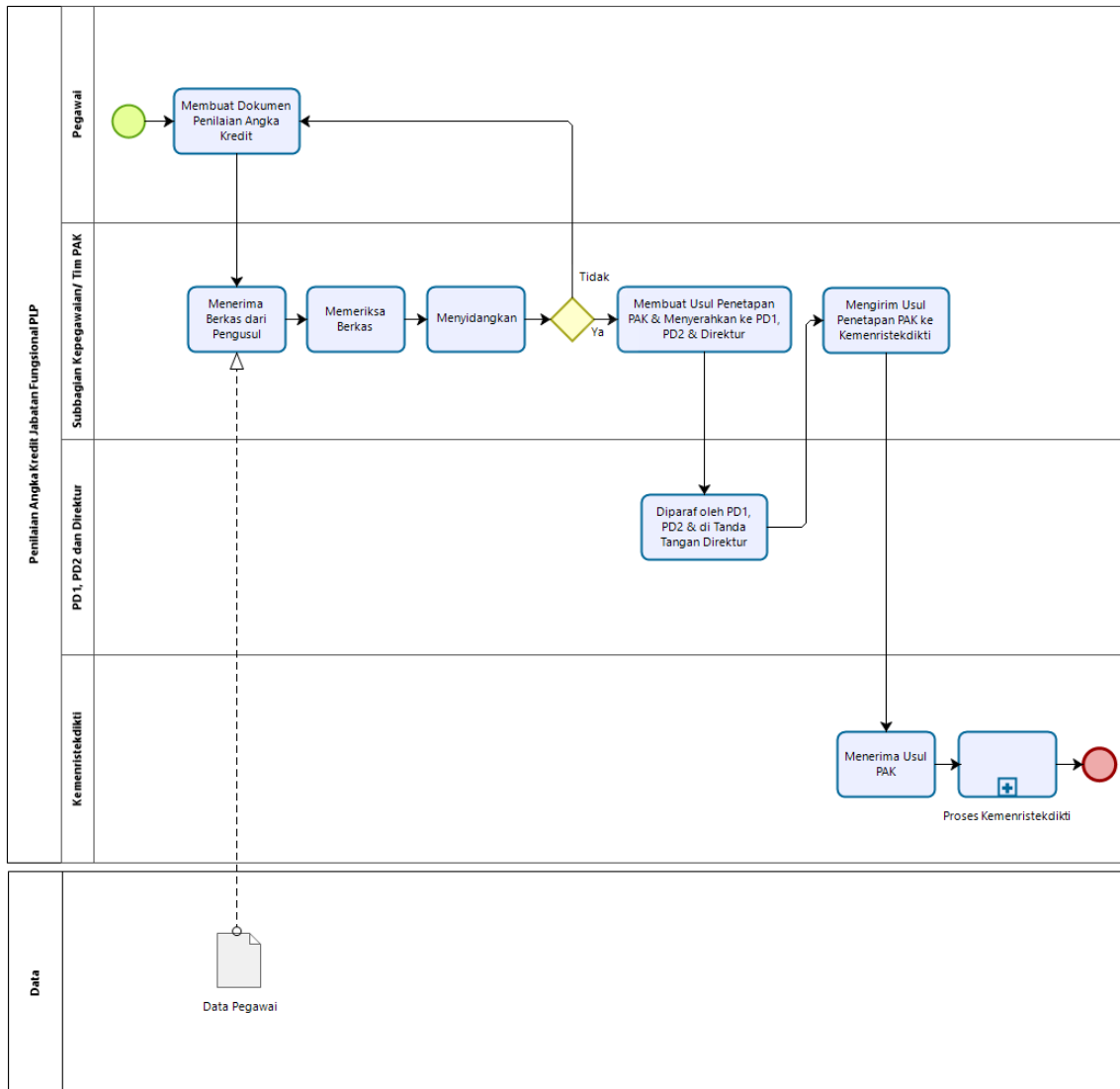

222. PENILAIAN PRESTASI KERJA PEGAWAI

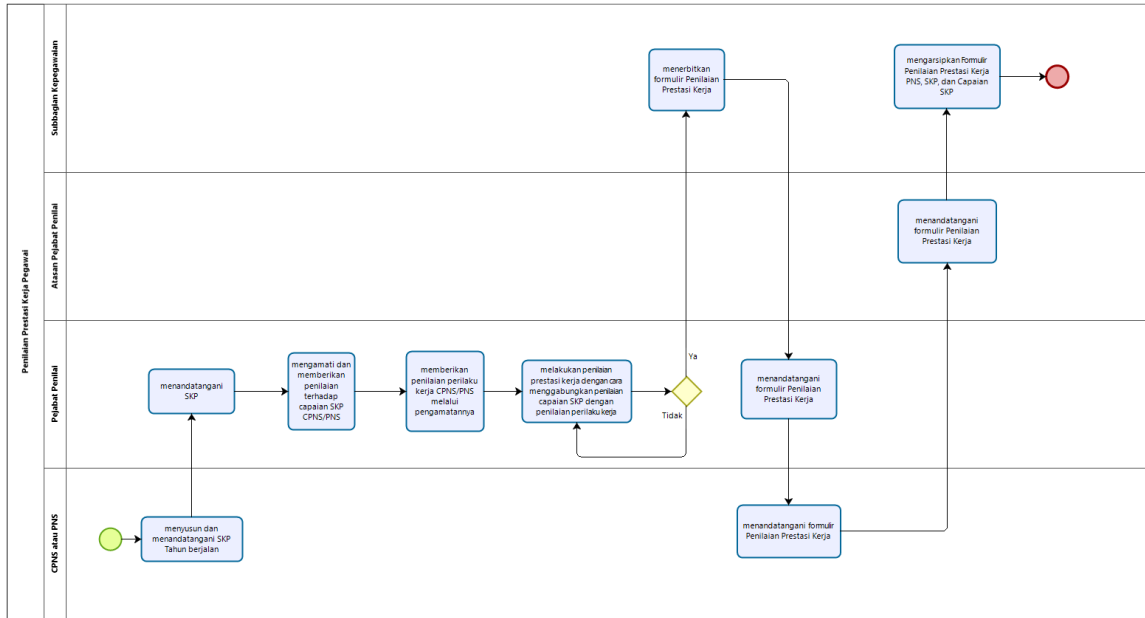

223. KENAIKAN PANGKAT REGULER

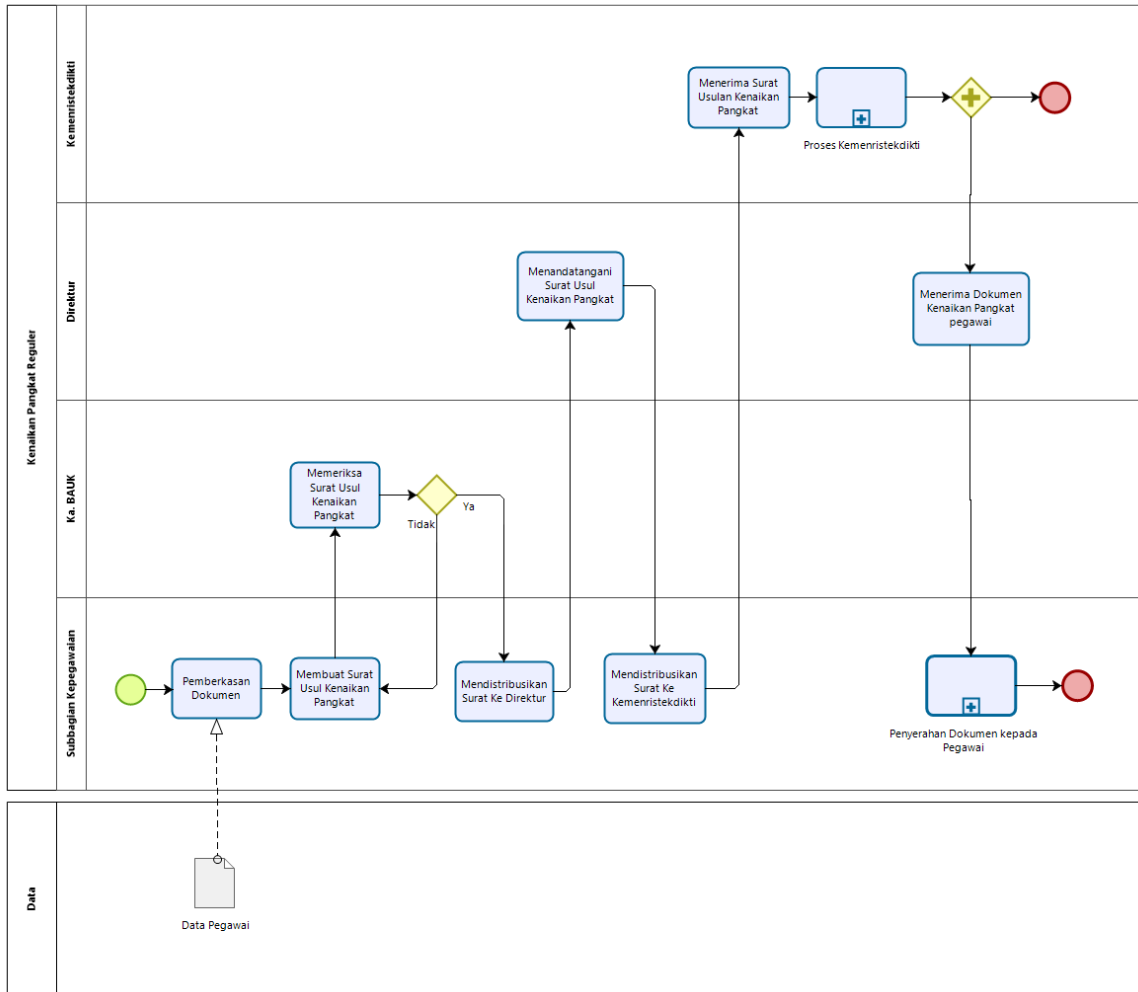

Powered by
bizagi
Modeler

224. PEMBUATAN SURAT KETERANGAN KERJA.

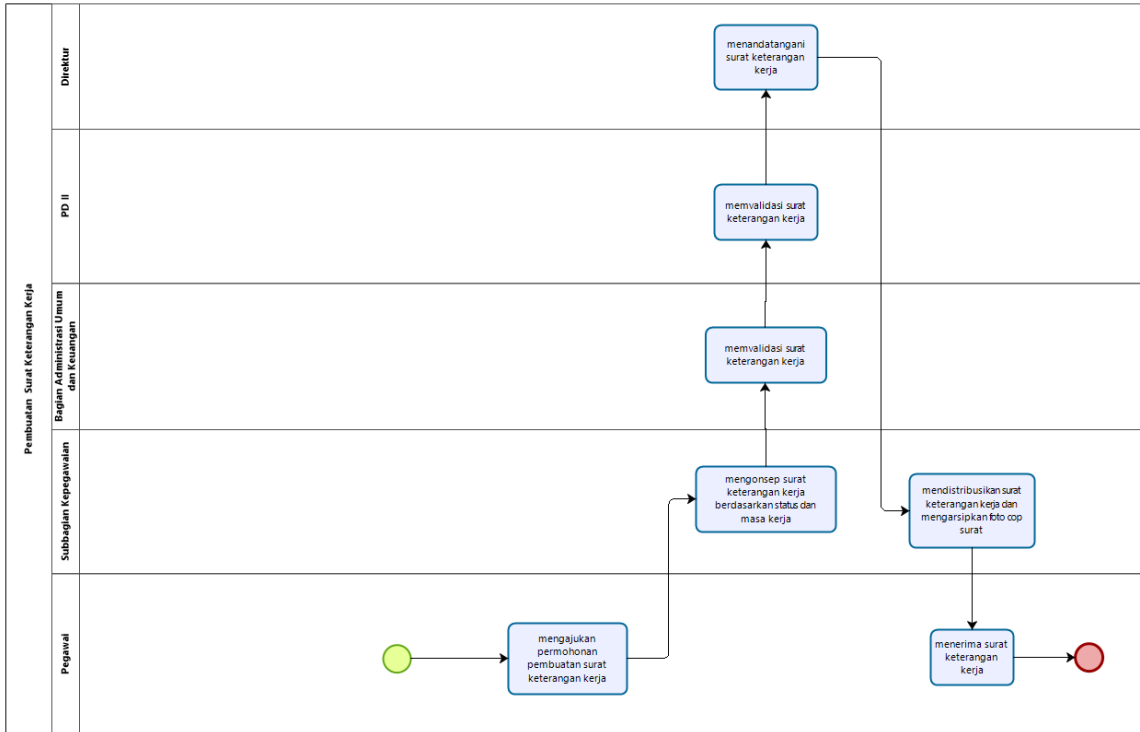

225. KENAIKAN PANGKAT JABATAN FUNGSIONAL PLP

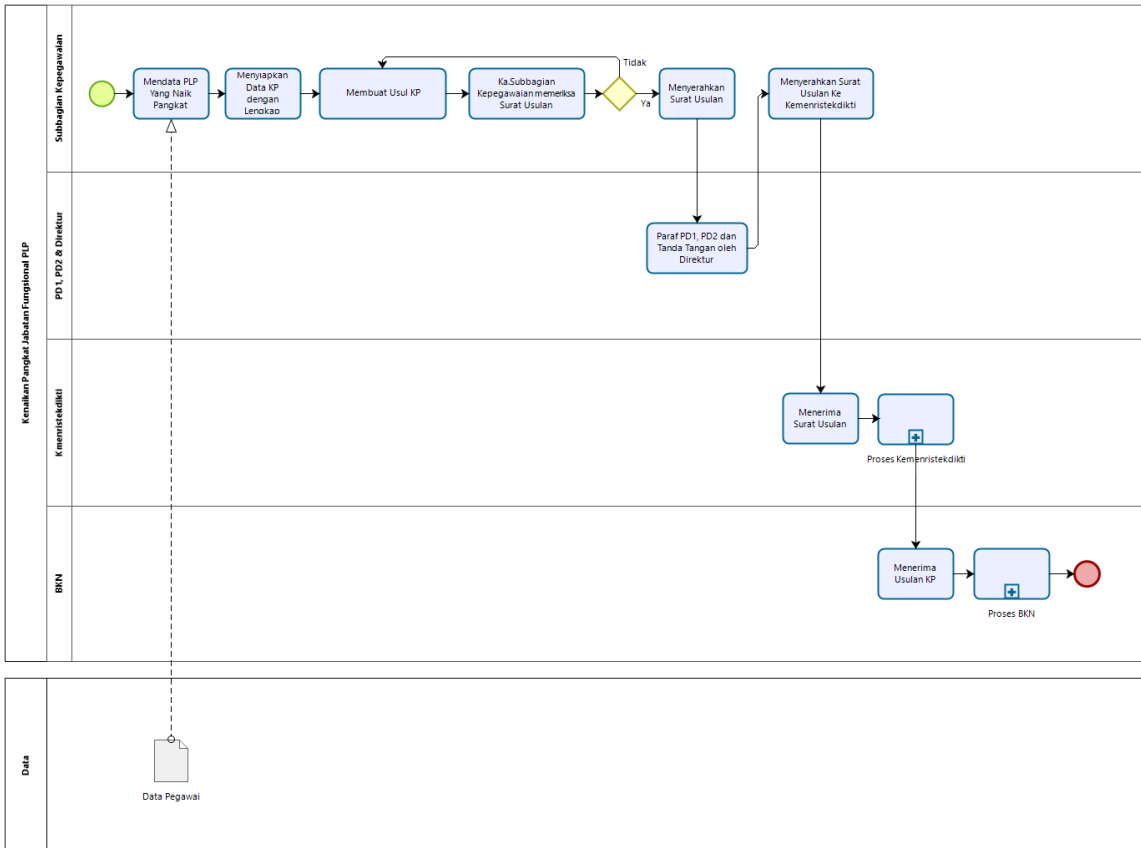

226. KENAIKAN PANGKAT JABATAN FUNGSIONAL TERTENTU PLP

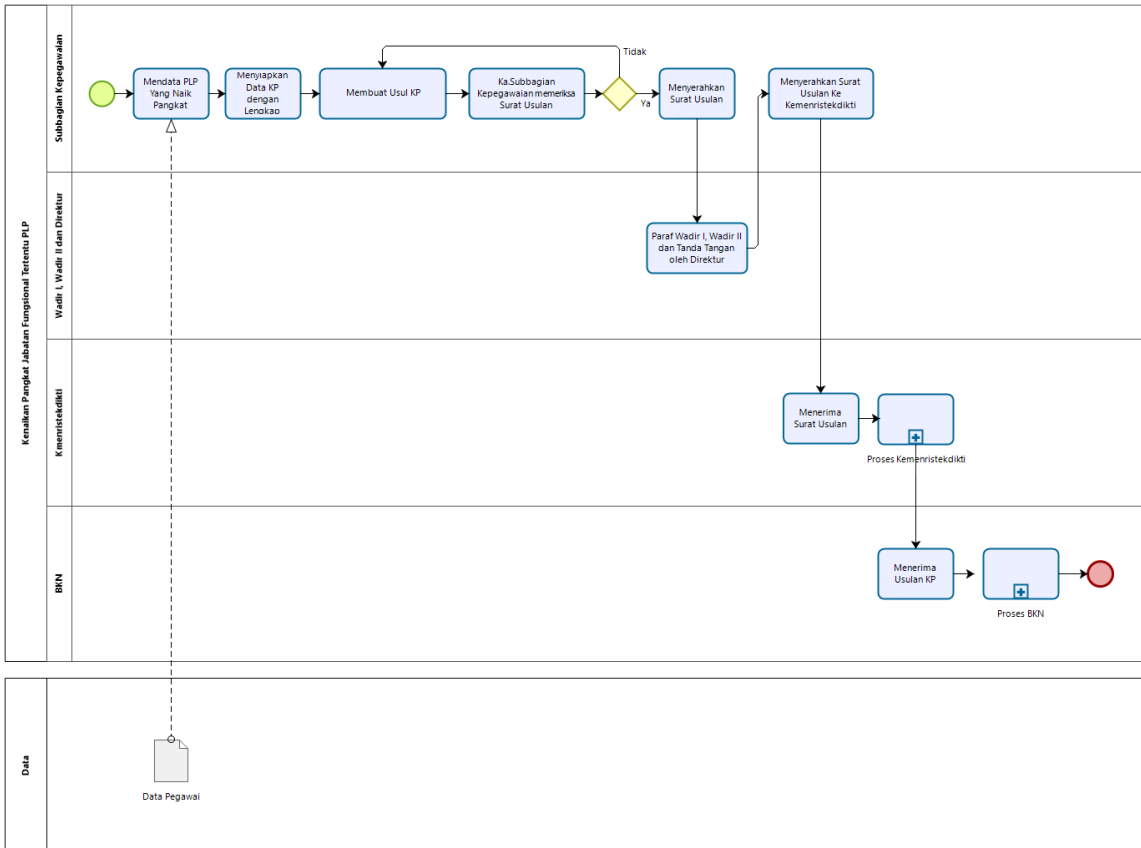

227. KENAIKAN PANGKAT PILIHAN PNS YANG MENDUDUKI JABATAN STRUKTURAL

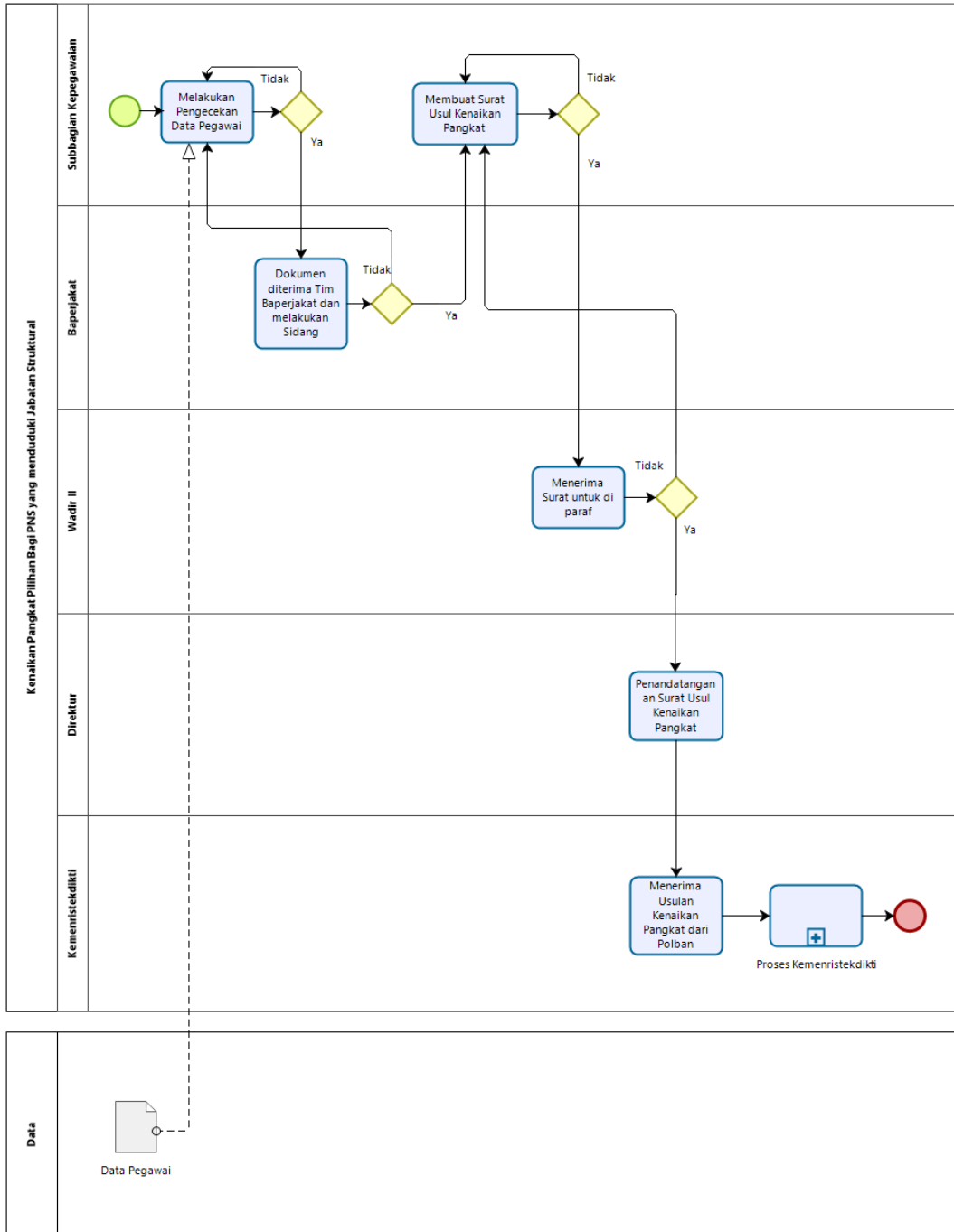

228. KENAIKAN PANGKAT PILIHAN PNS YANG MENDUDUKI JABATAN FUNGSIONAL TERTENTU

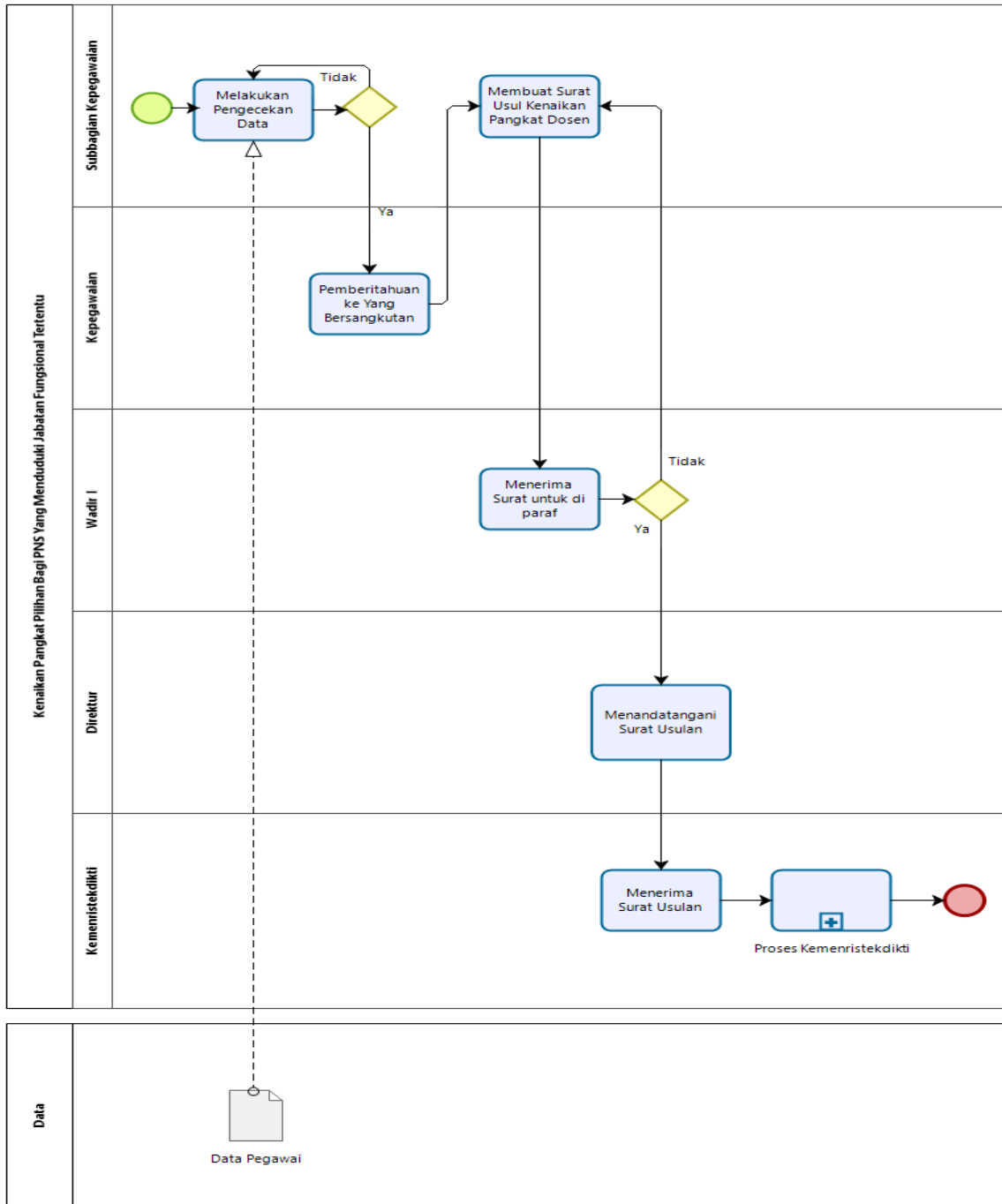

229. KEUANGAN

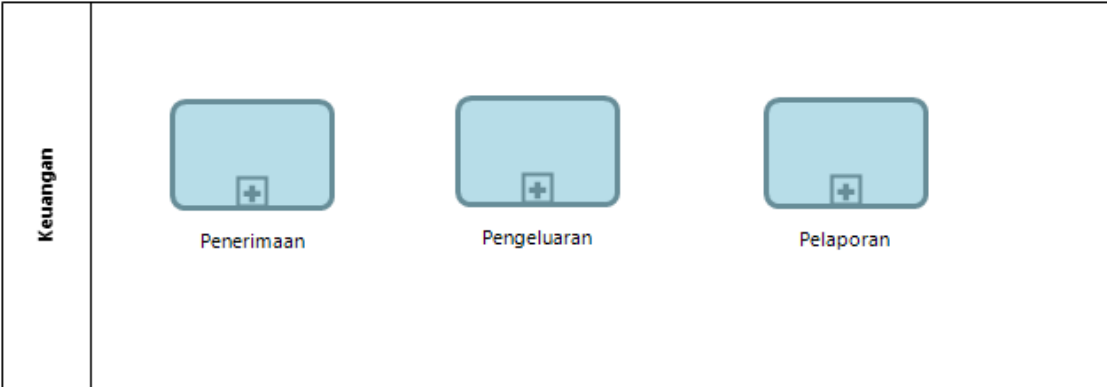

230. PENERIMAAN



231. PENERIMAAN PNBP

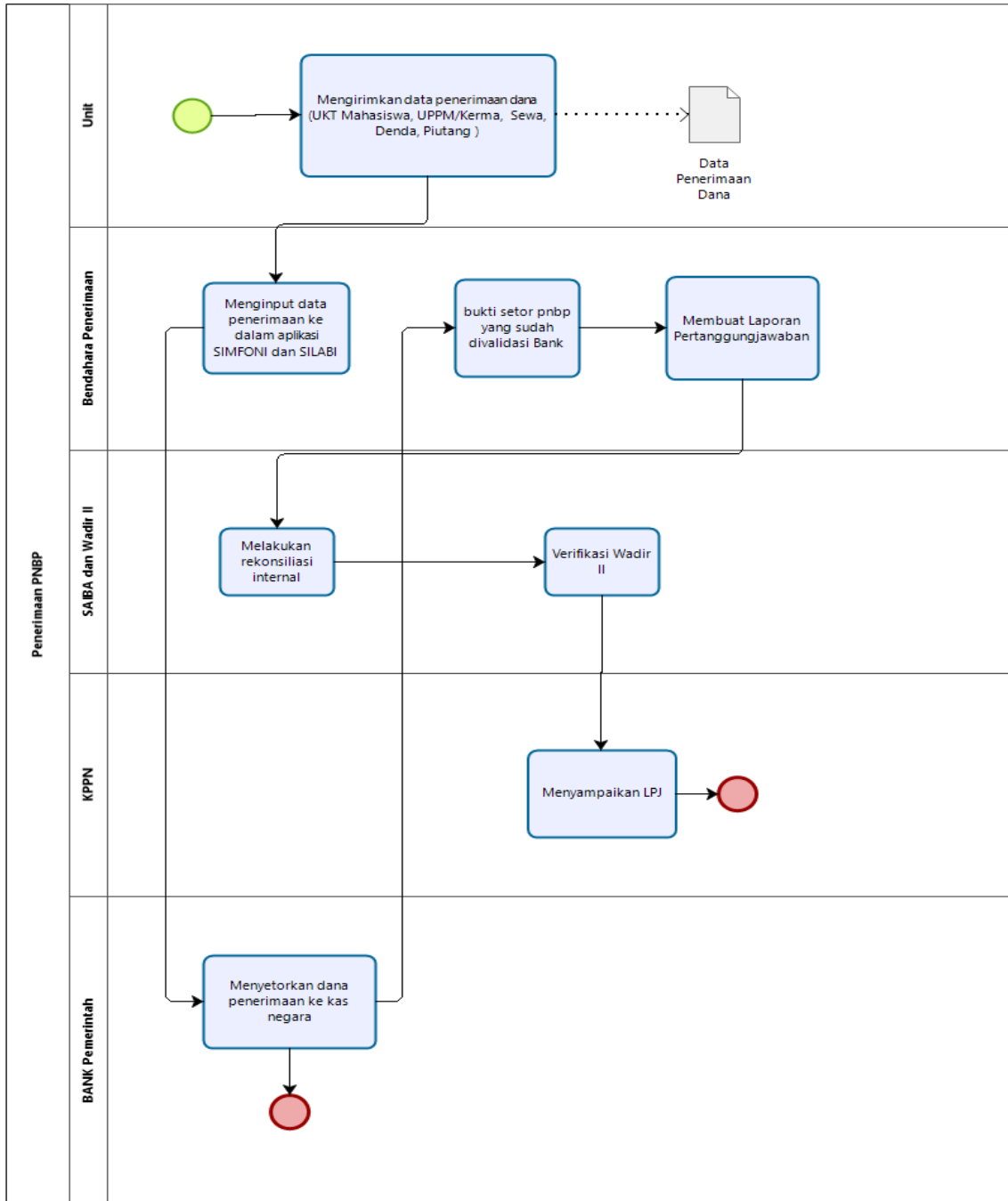

232. PENGELUARAN

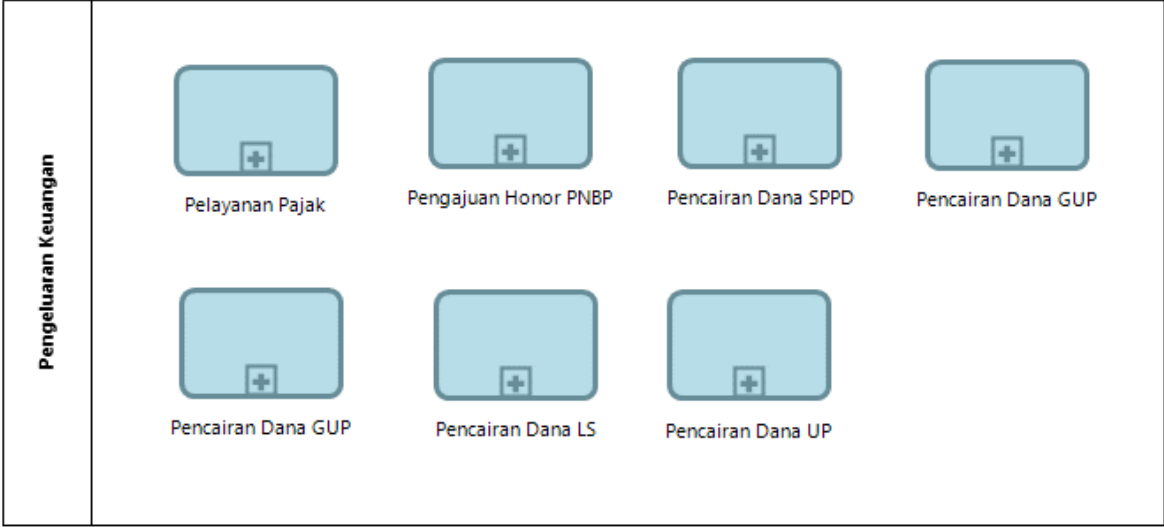

233. PELAYANAN PAJAK

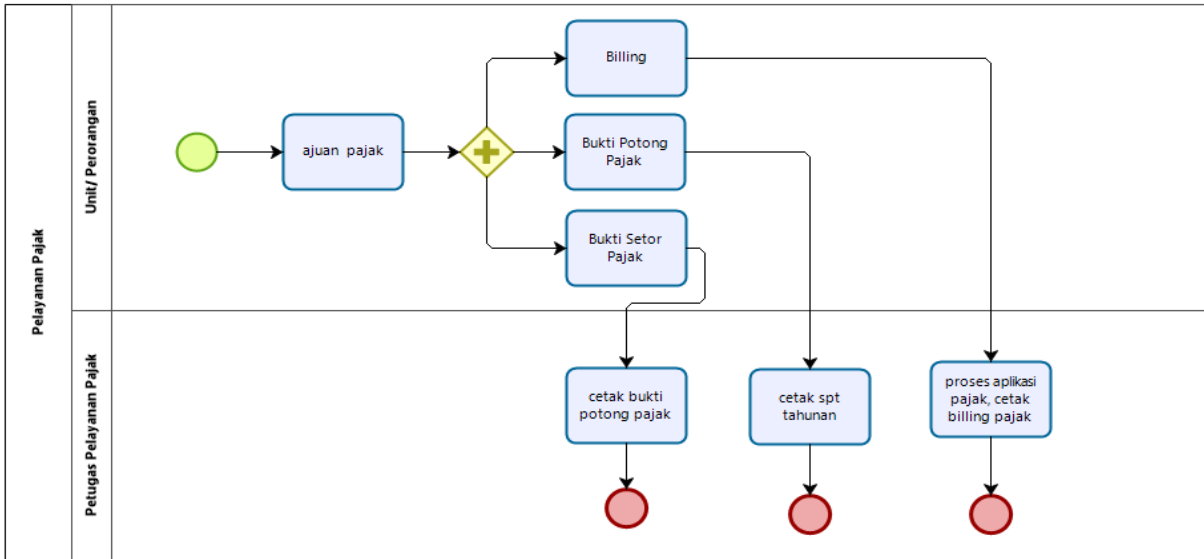

234. PENGAJUAN HONOR PNBP

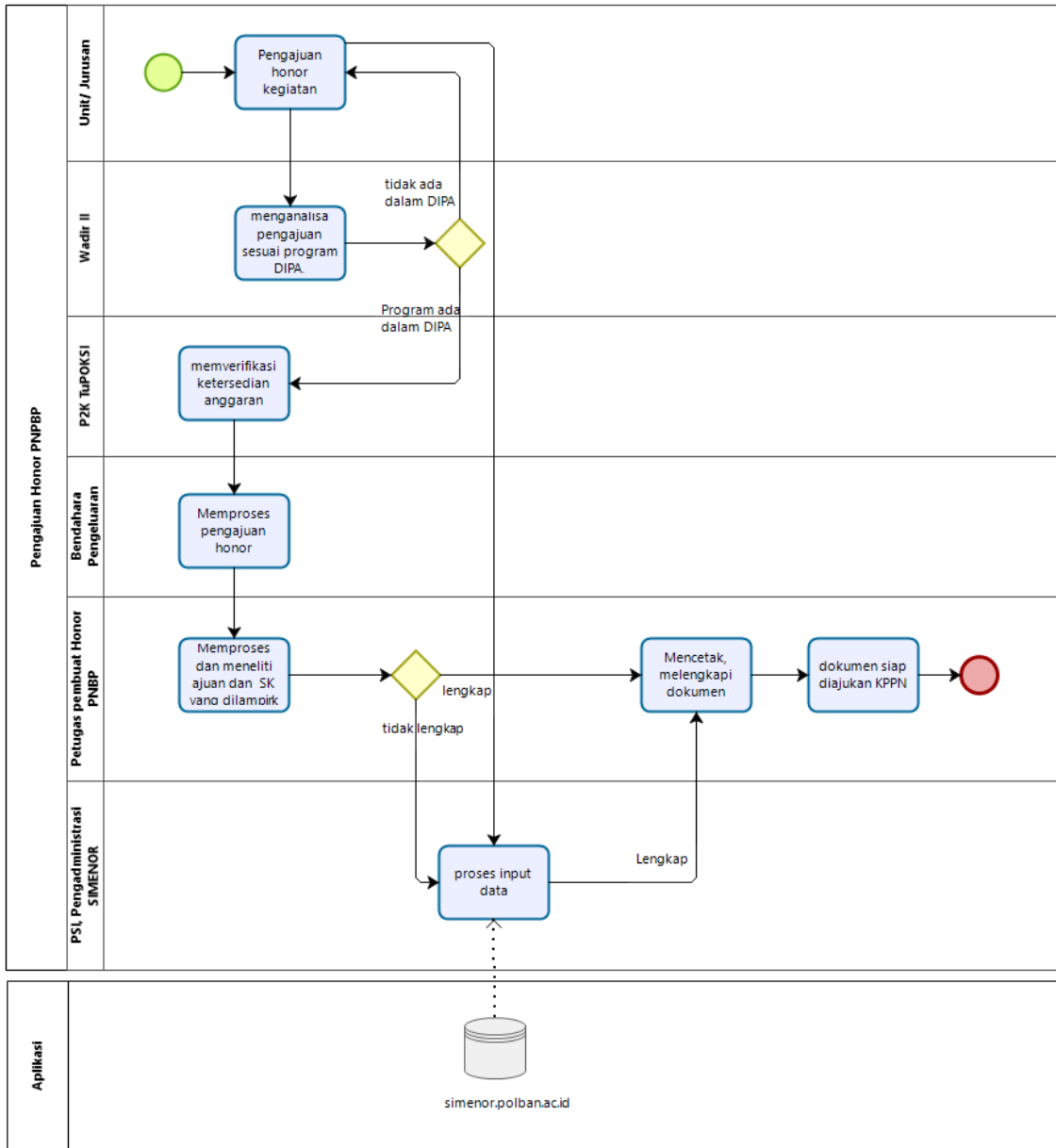

235. PENCAIRAN DANA GUP

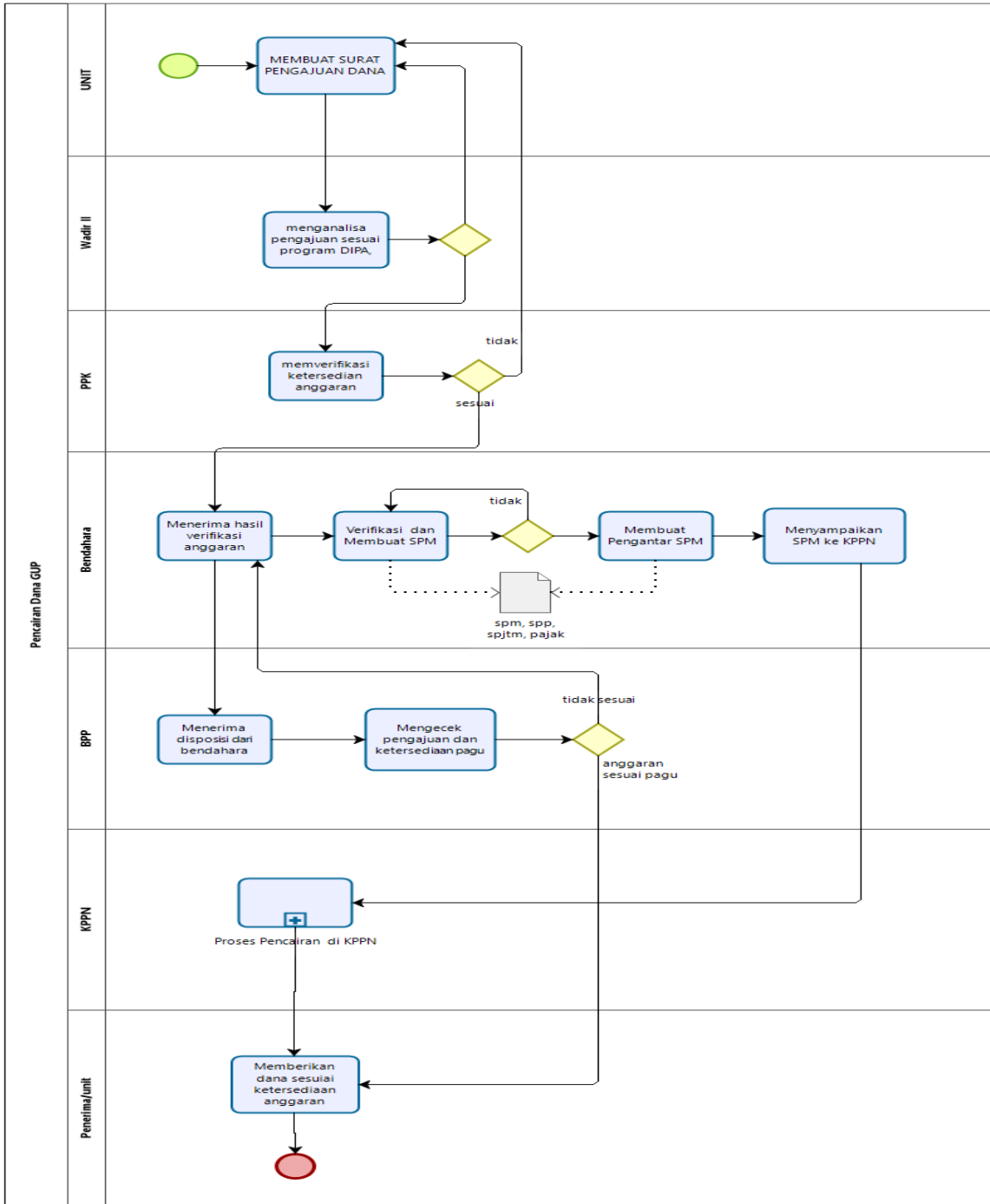

236. PENCAIRAN DANA LS

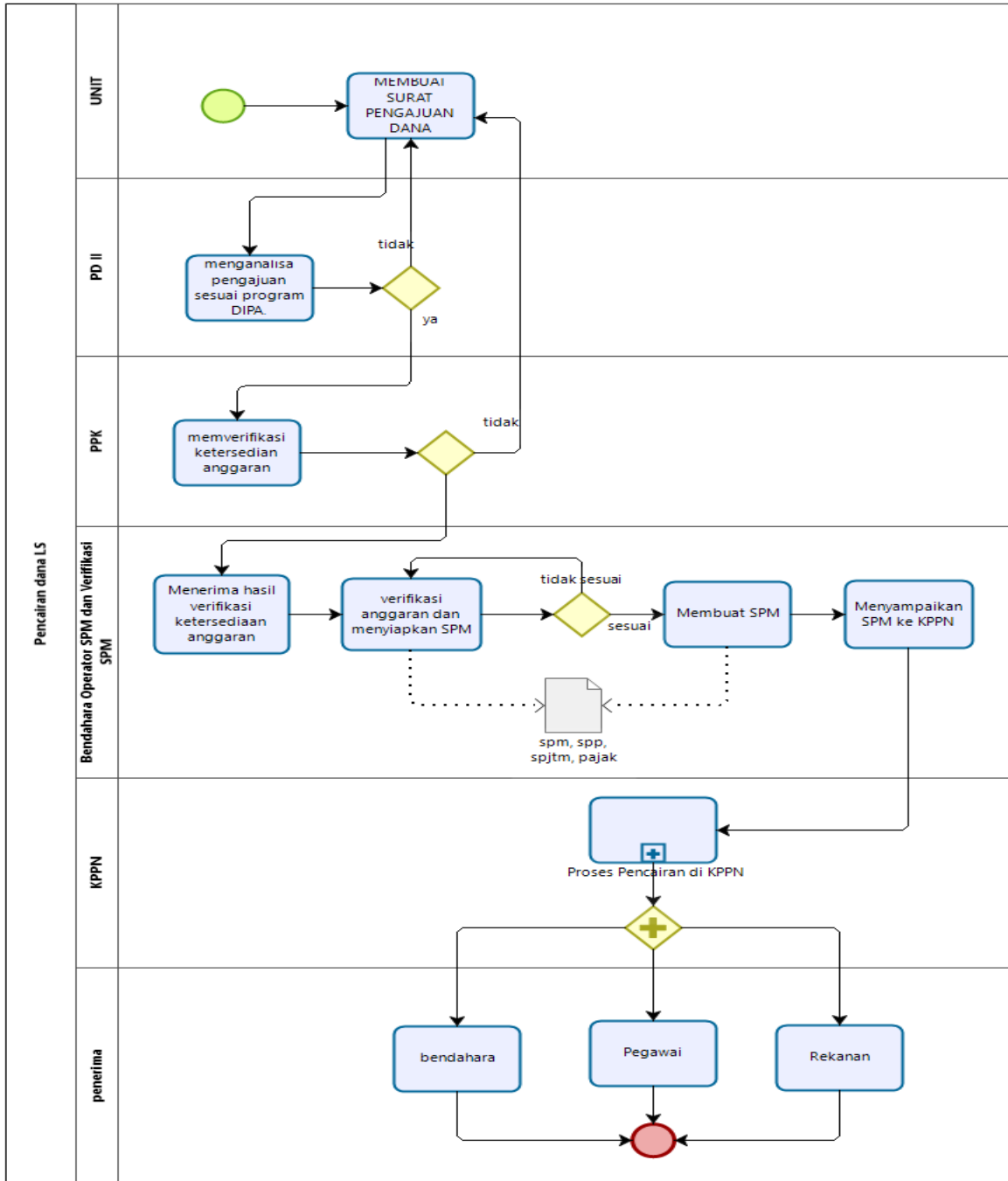

237. PENCAIRAN DANA SPPD

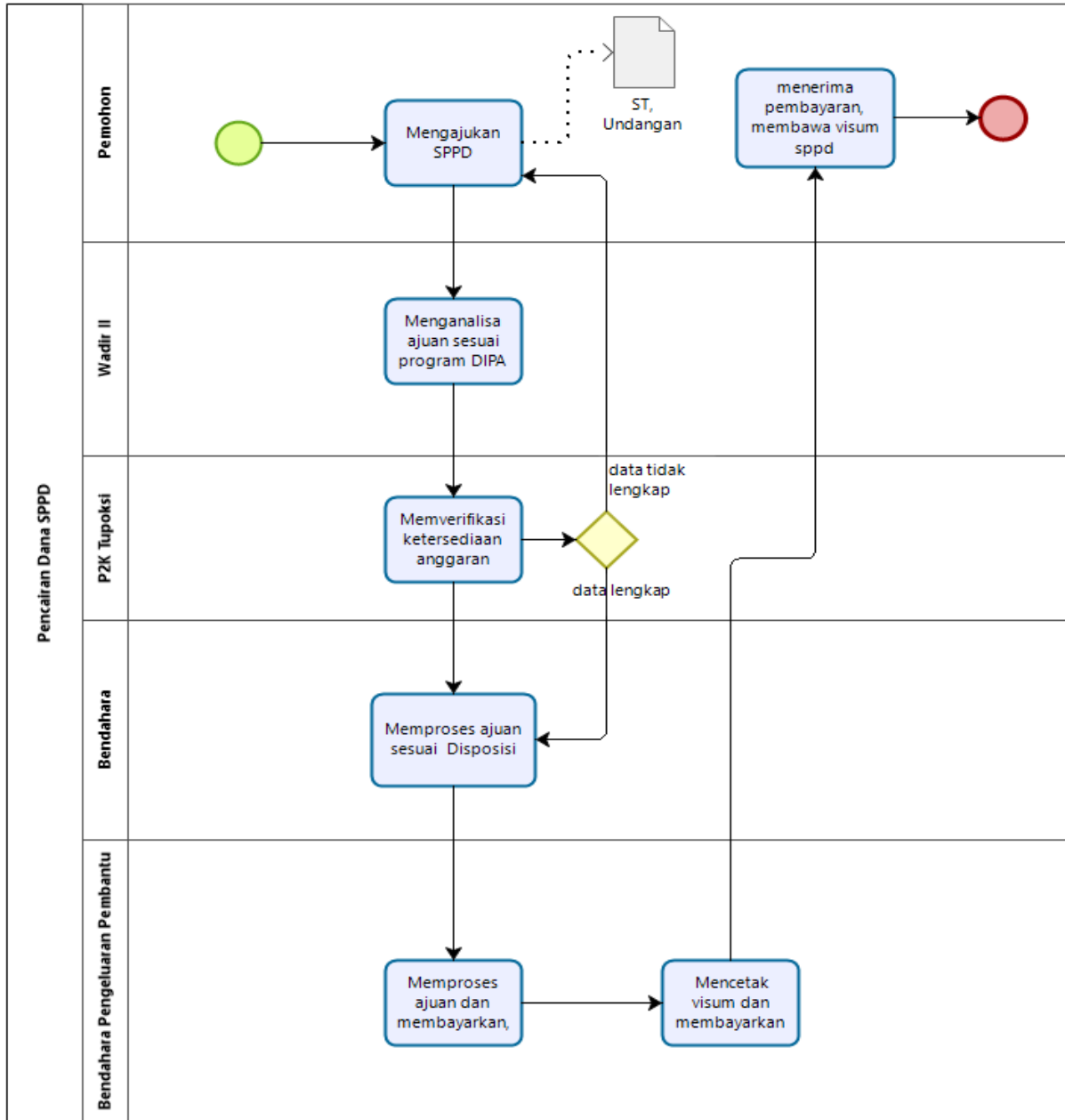

238. PENCAIRAN DANA GU

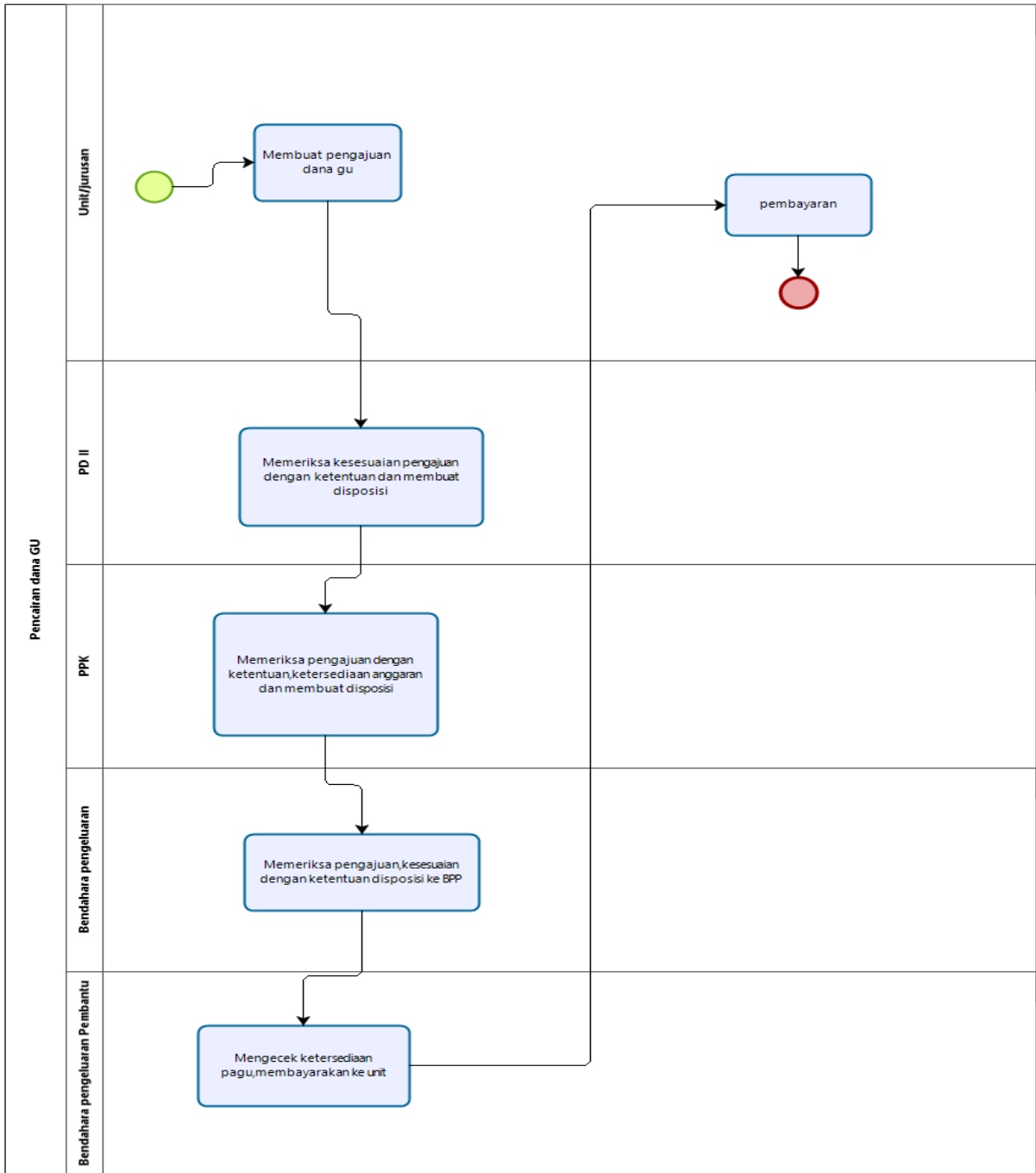

239. PENCAIRAN DANA UP

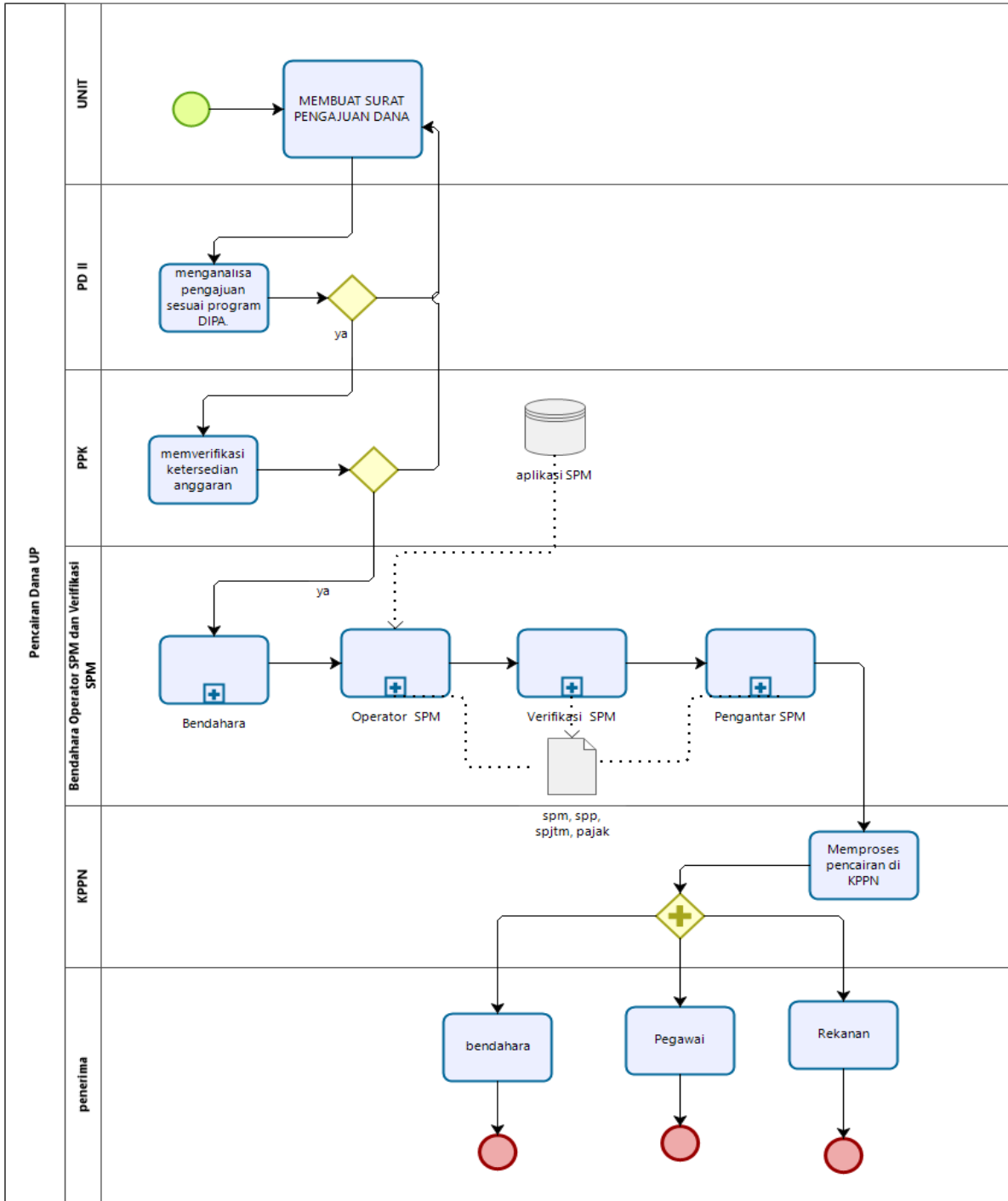

240. PELAPORAN



241. PELAPORAN KEUANGAN

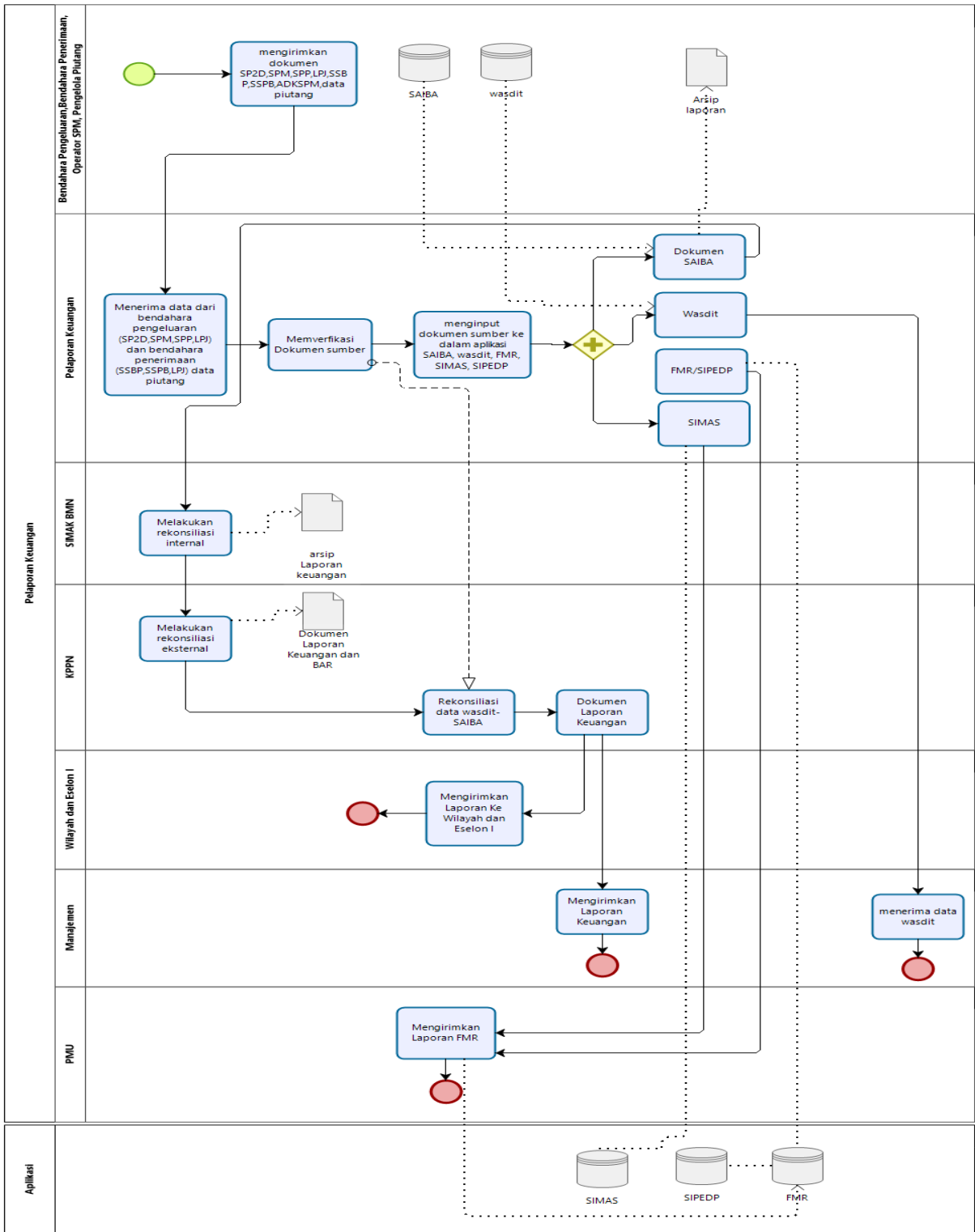

242. PELAPORAN PAJAK MASA

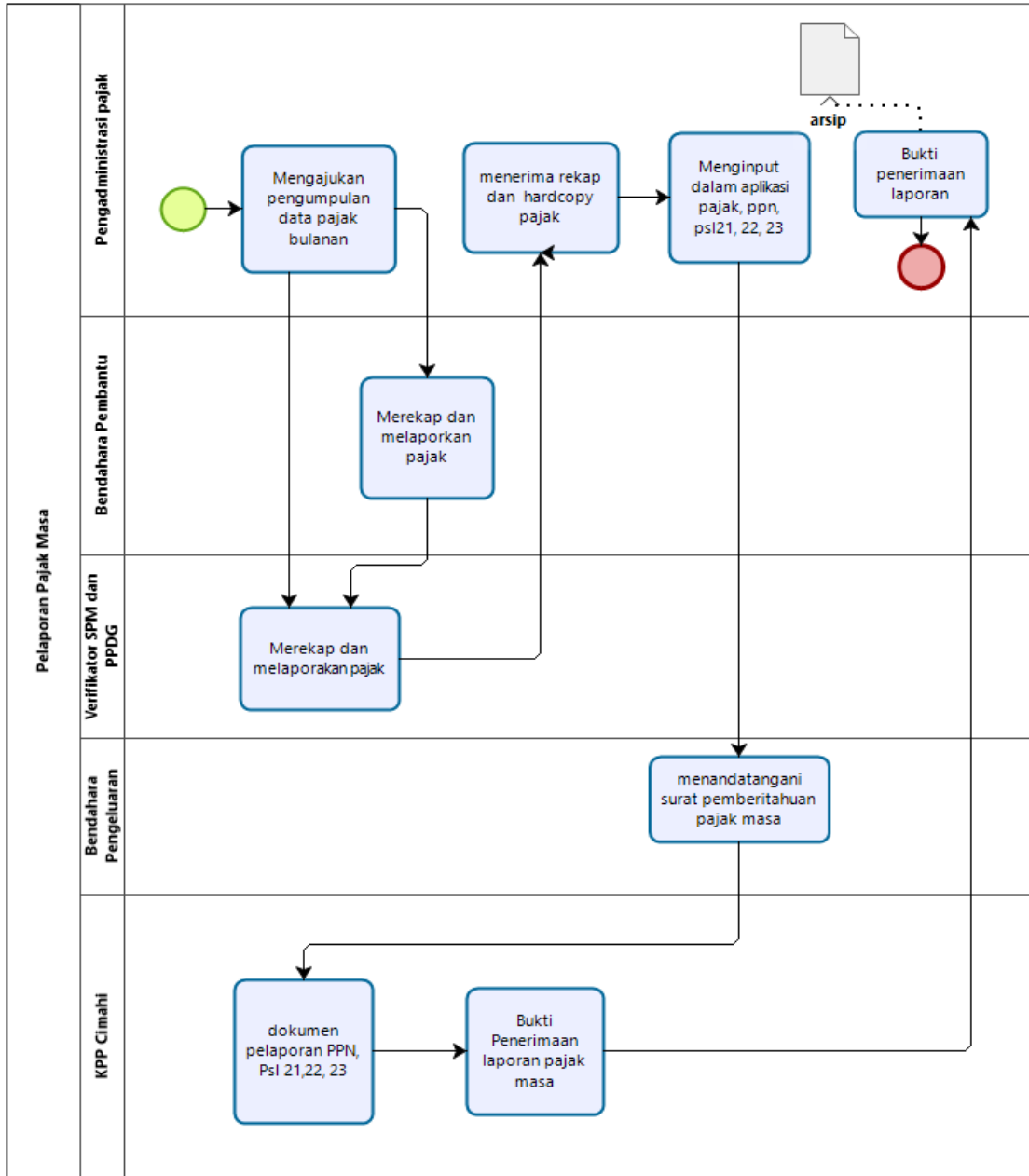

243. KEAMANAN



244. PENGATURAN KEAMANAN

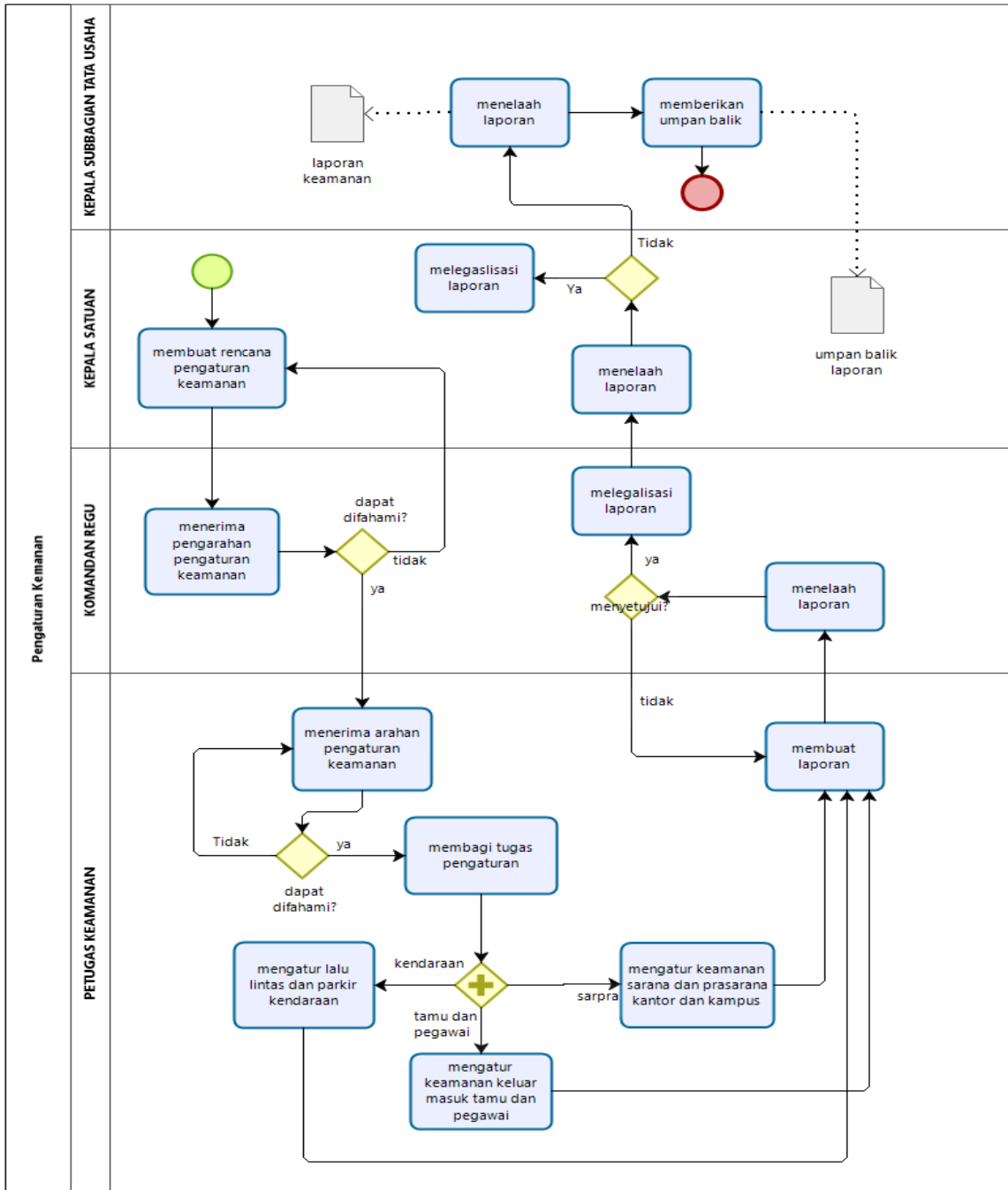

245. PENJAGAAN KEAMANAN

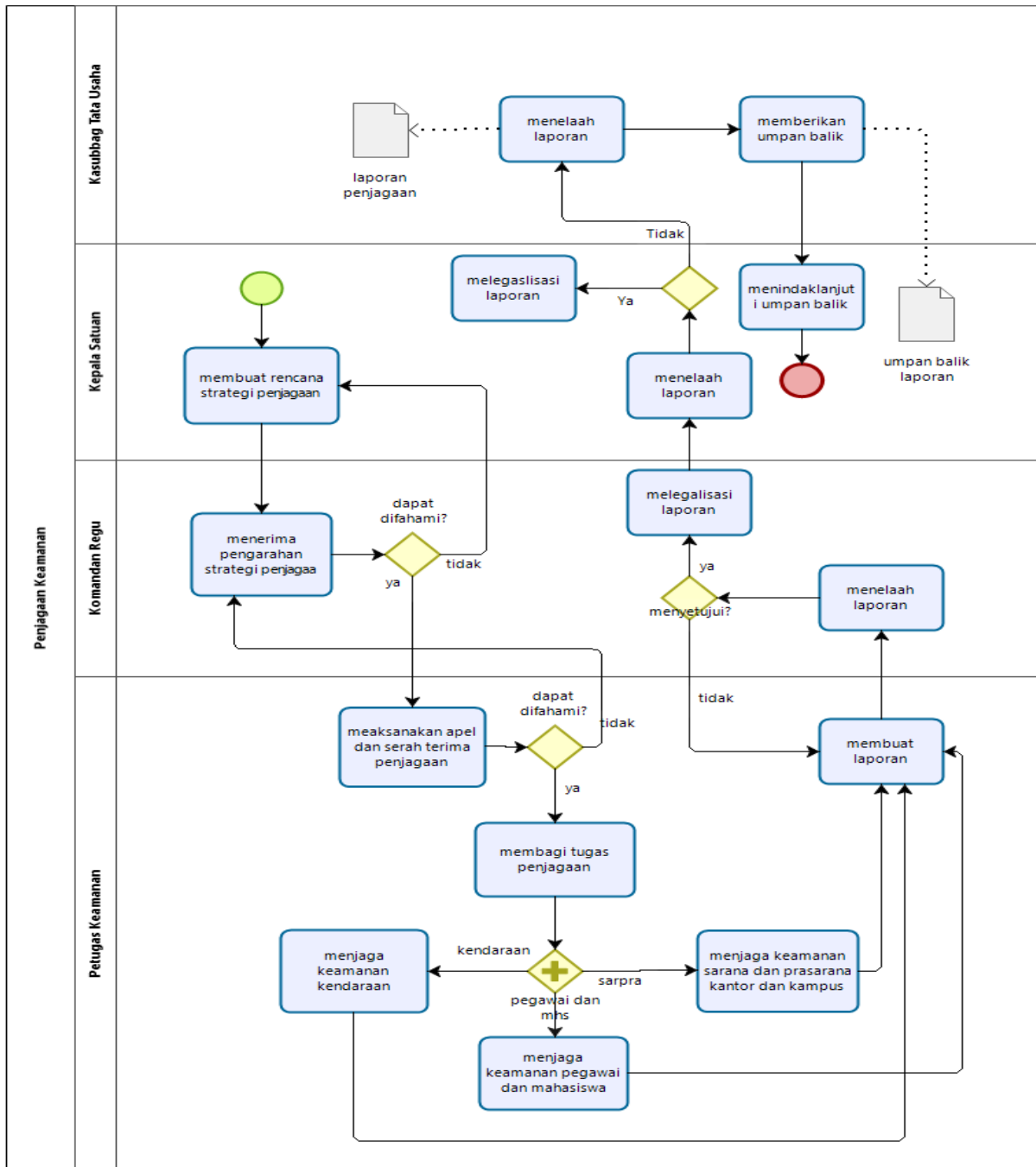

246. PATROLI

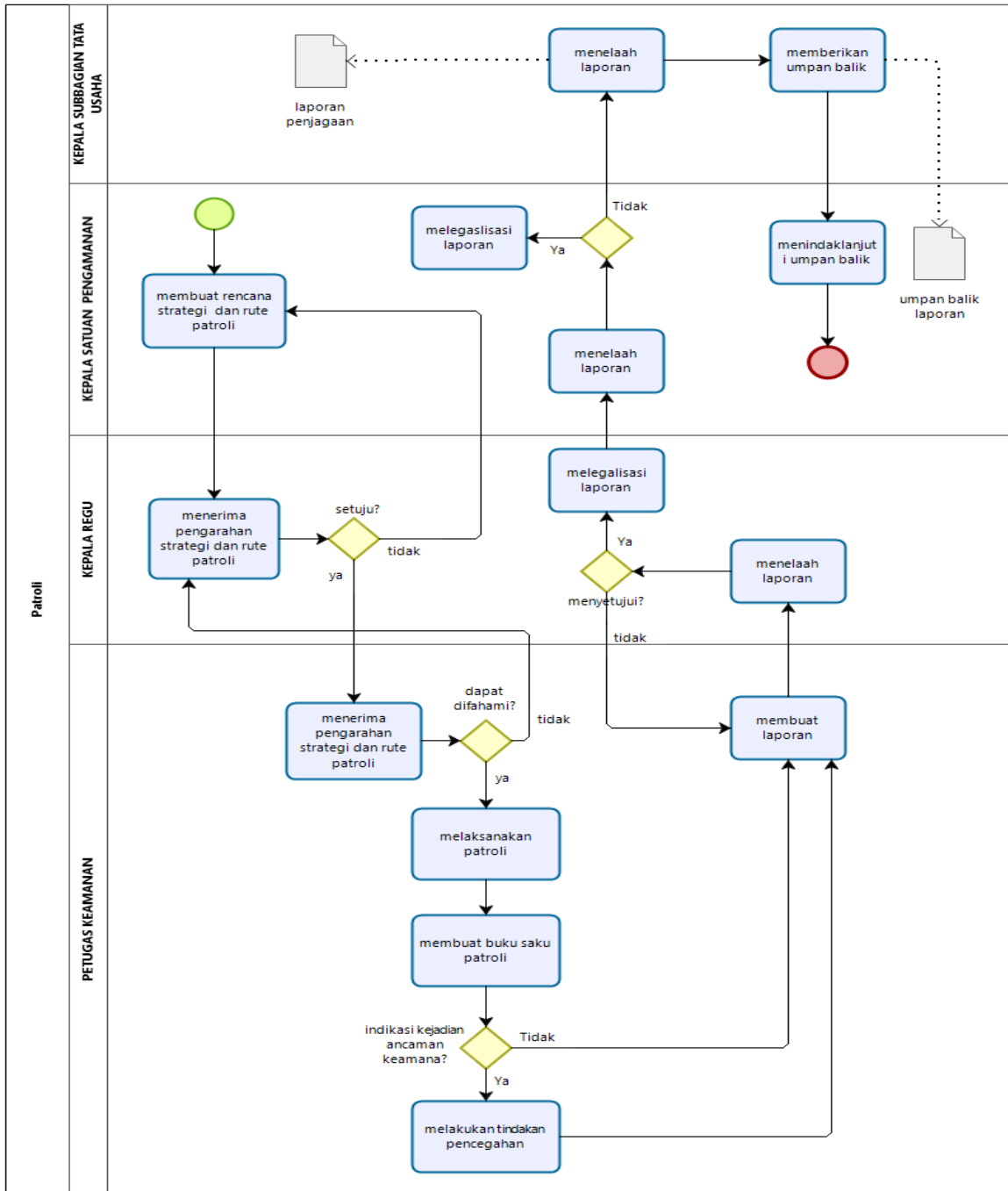

247. PENGAWALAN

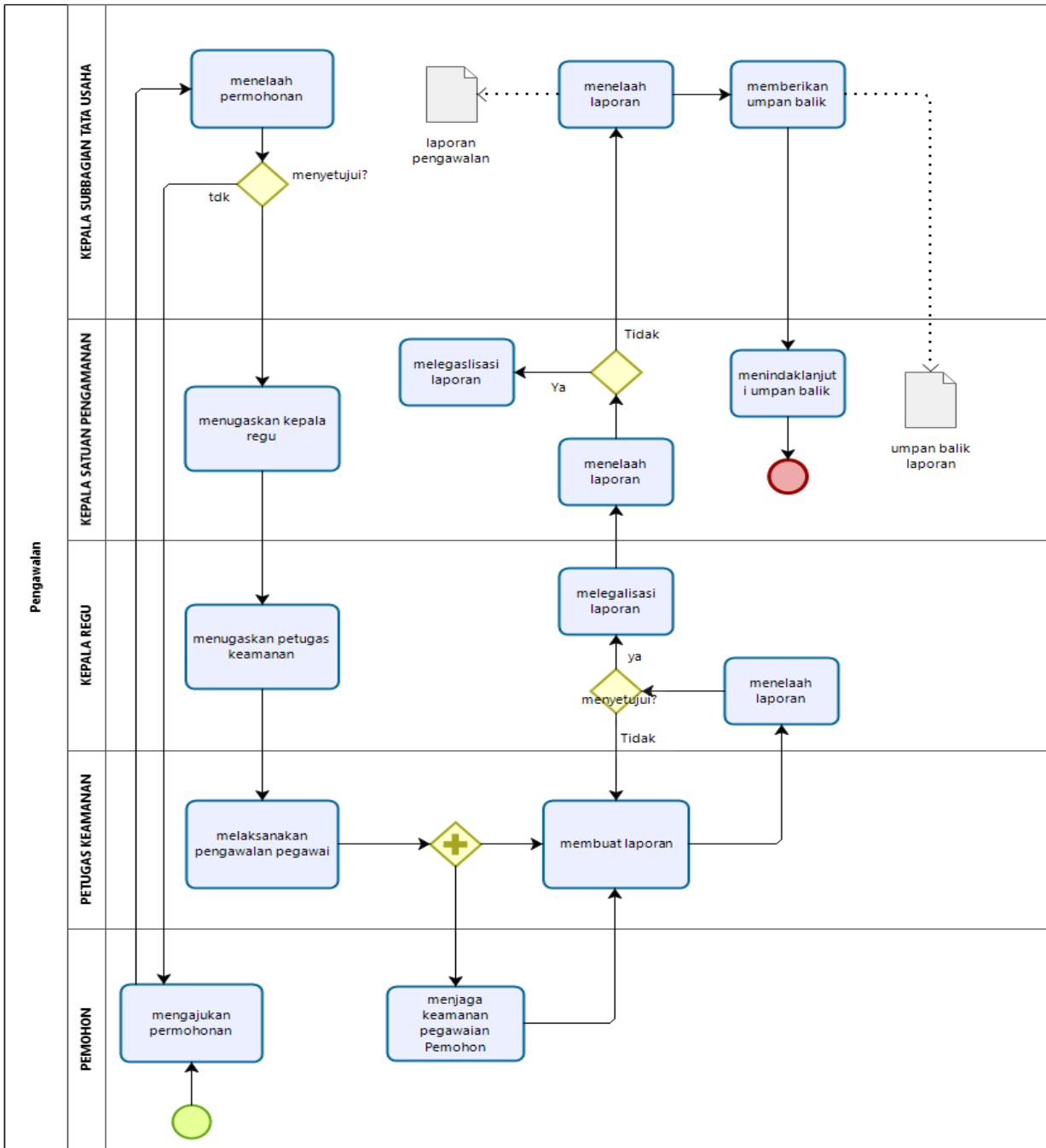

248. HUMAS



249. PELAKSANAAN ACARA SEREMONIAL AKADEMIK

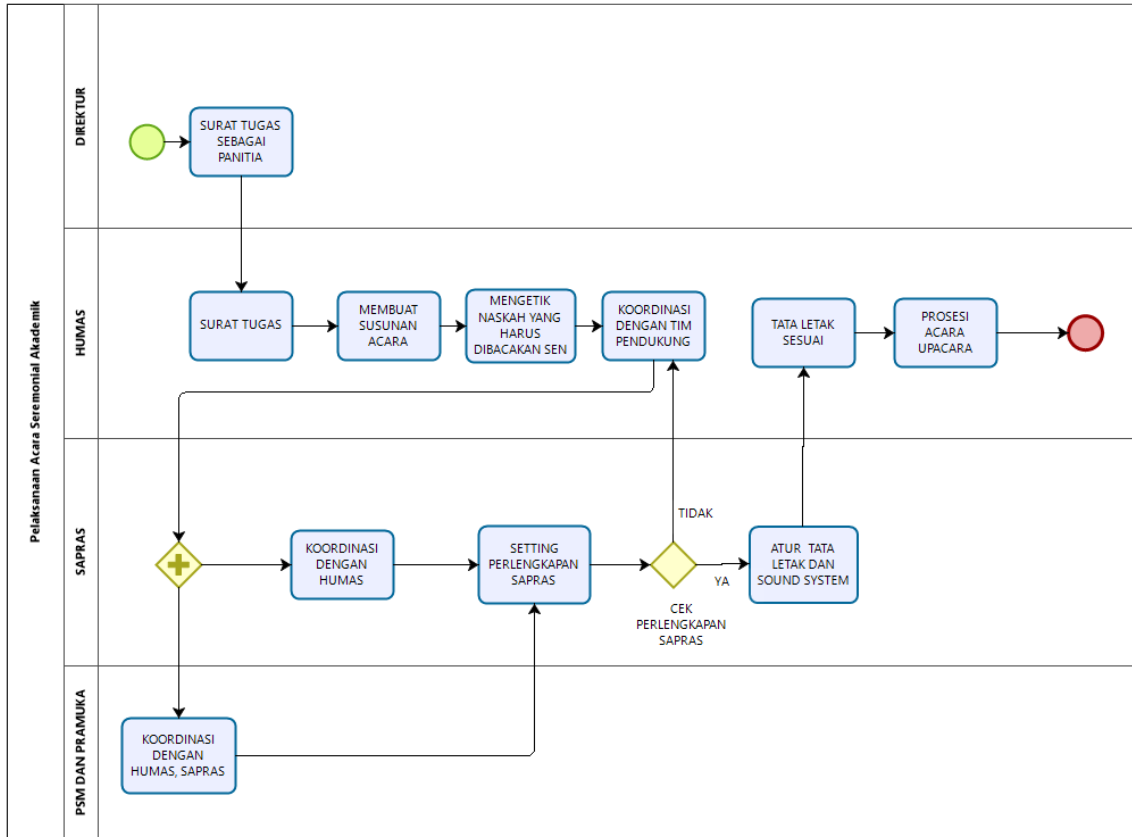

250. COMPANY PROFILE

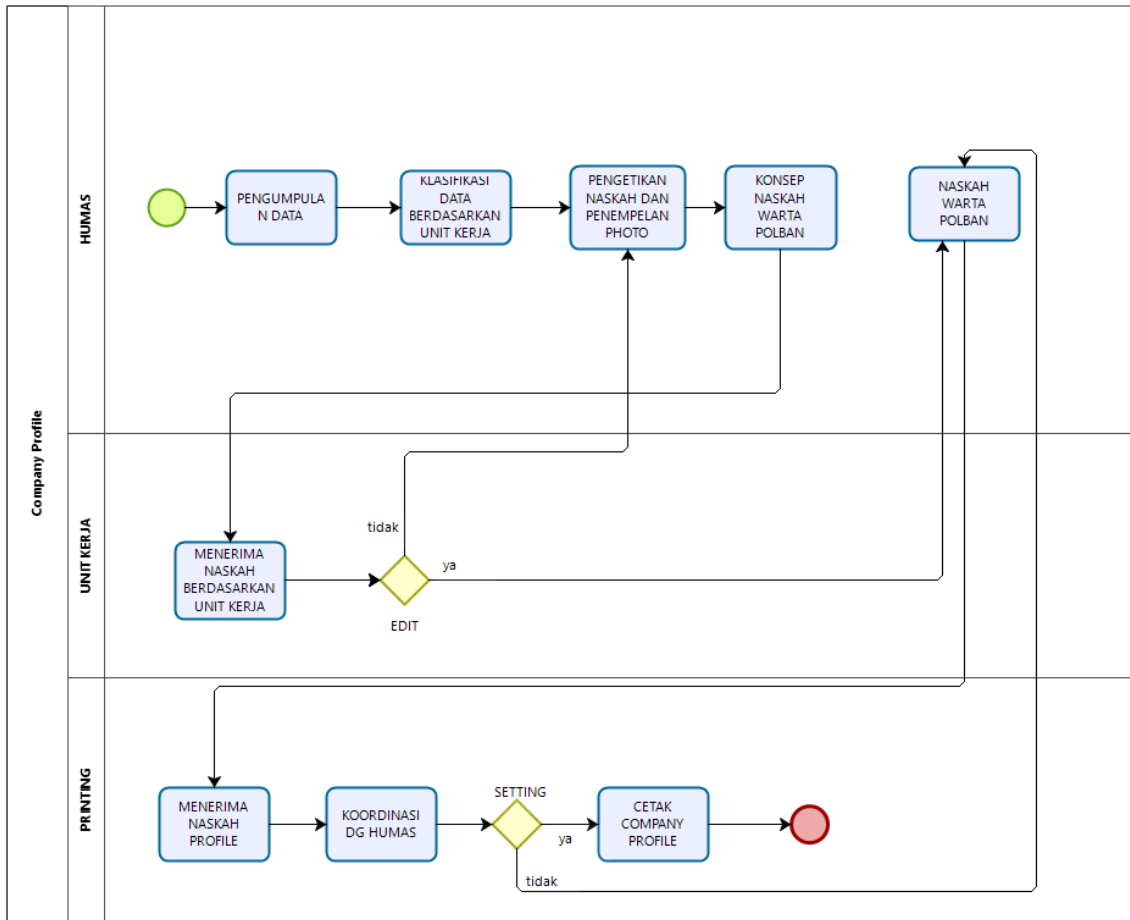

251. UPACARA BENDERA

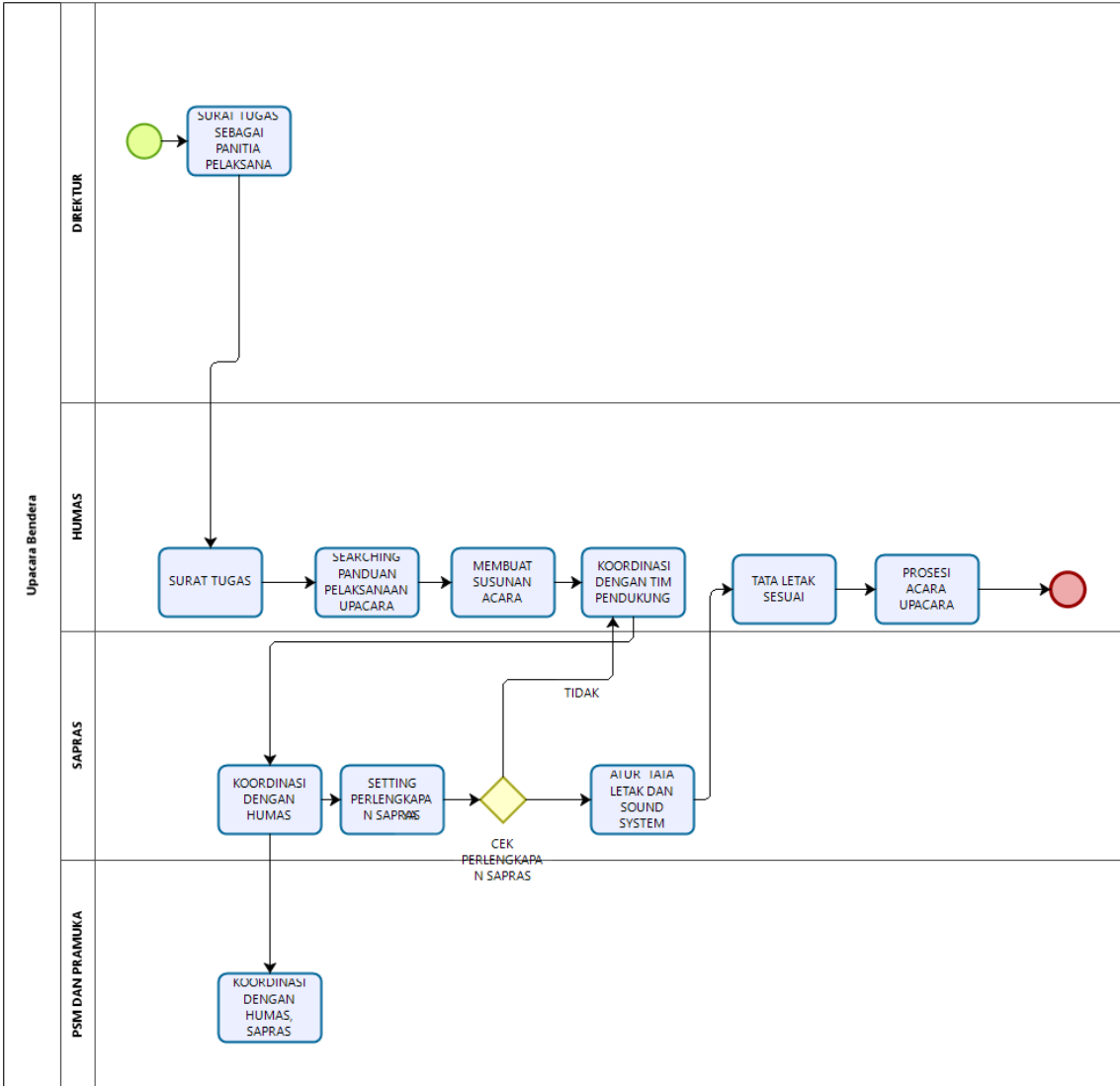

252. PENANDATANGANAN MOU

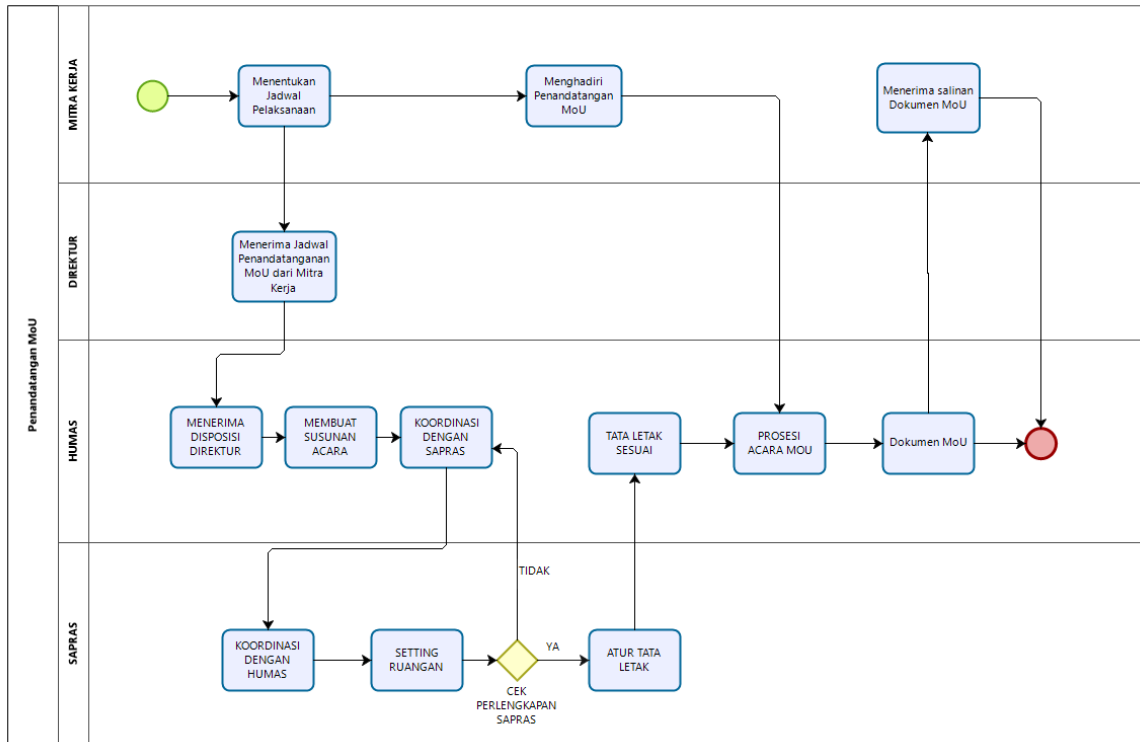

253. PERMINTAAN CINDERAMATA

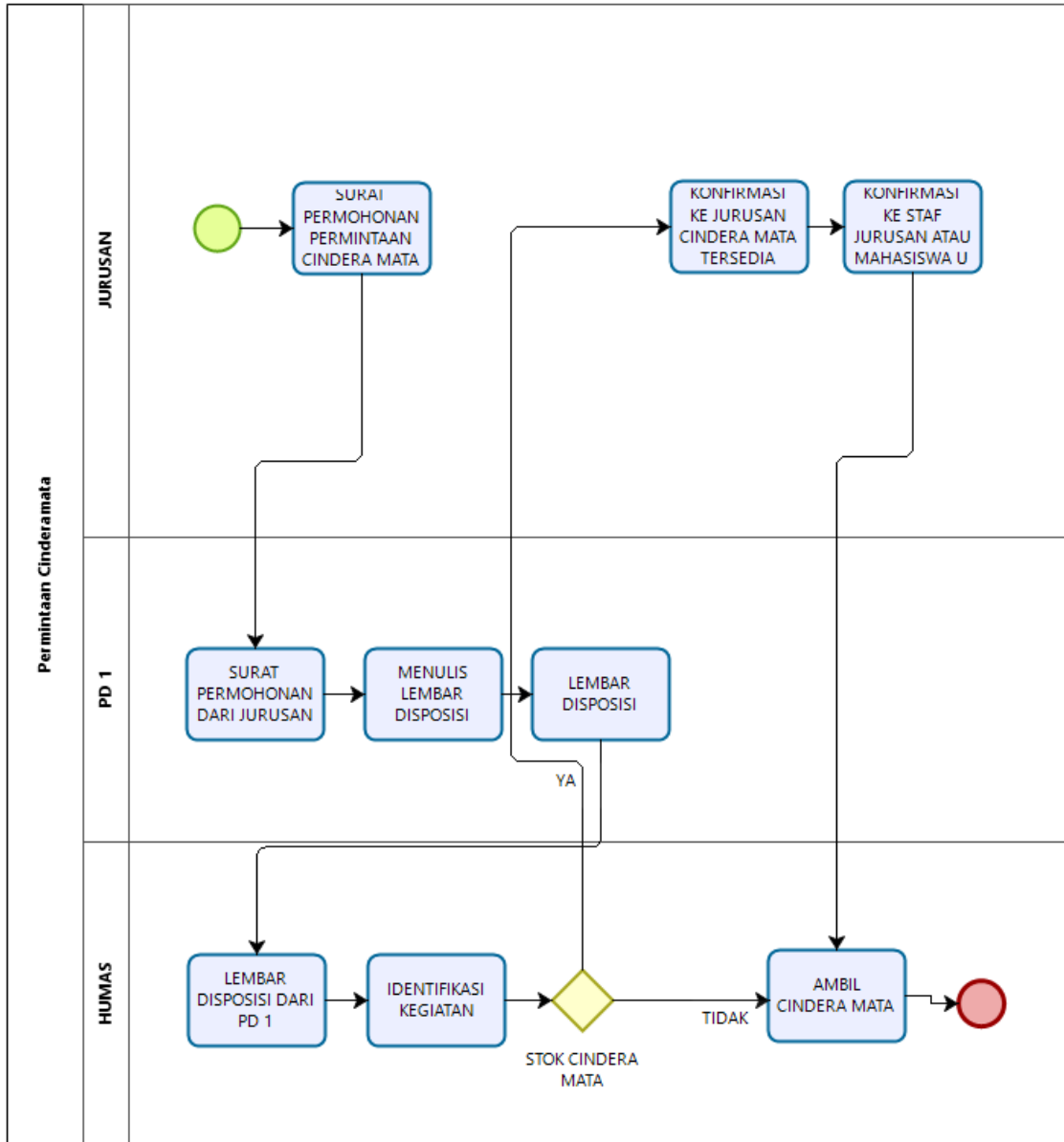

254. LAYANAN TAMU PIMPINAN

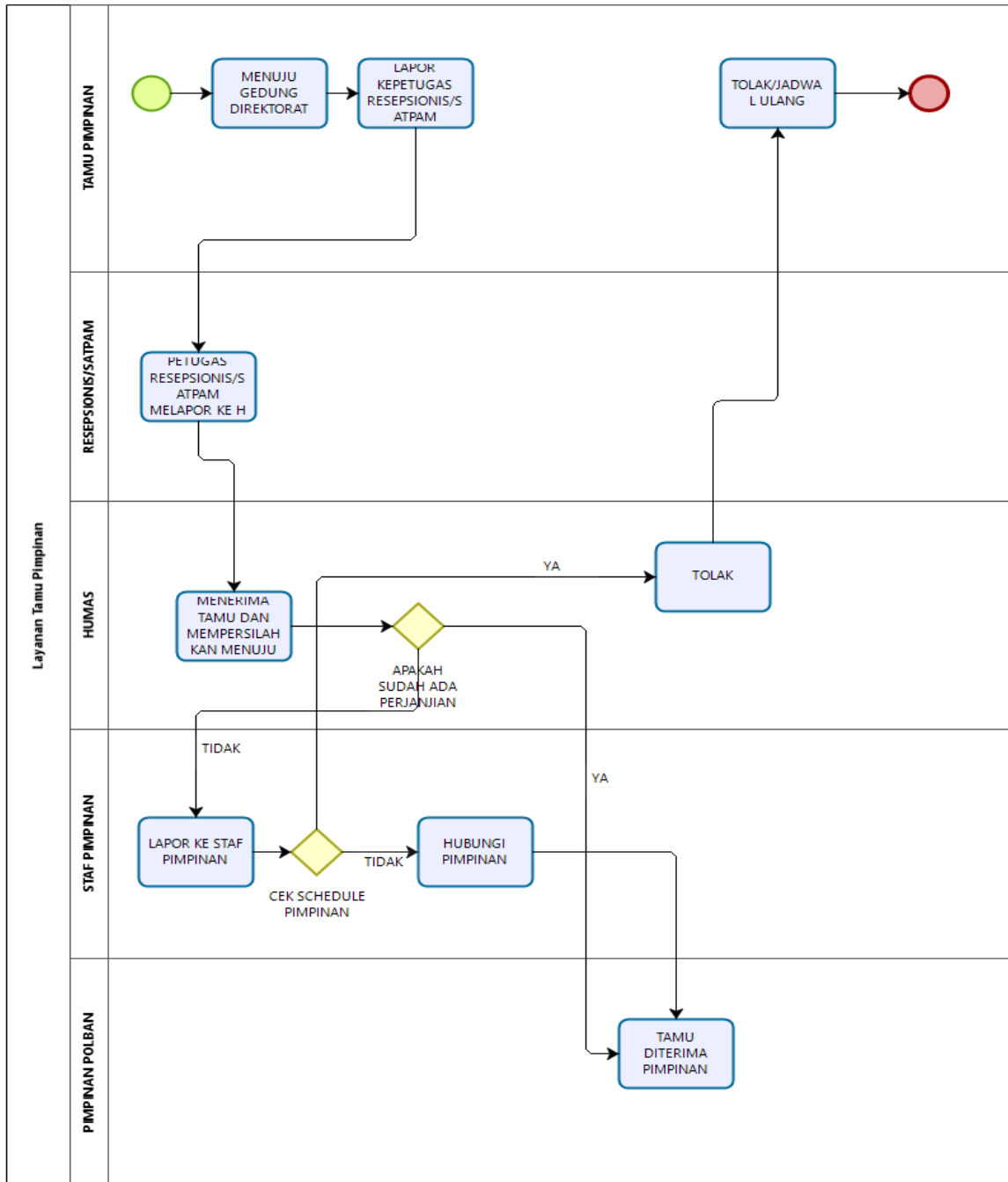

255. MEDIA CETAK

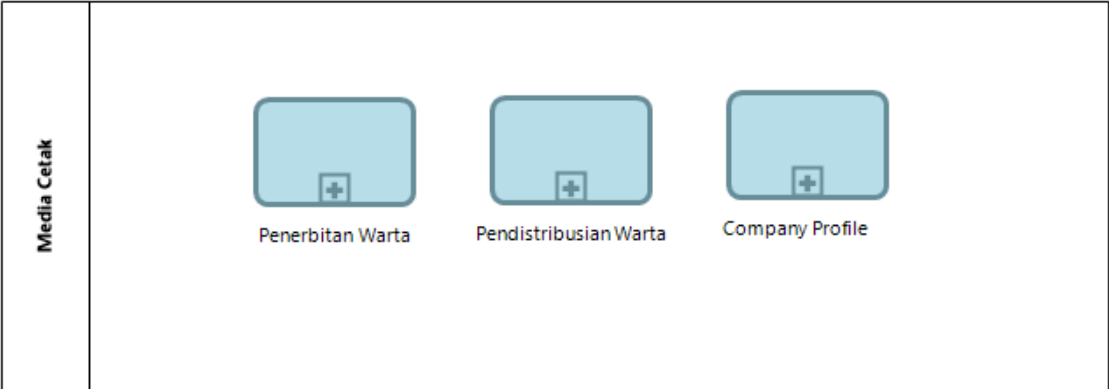

256. PUBLIKASI DAN PROMOSI

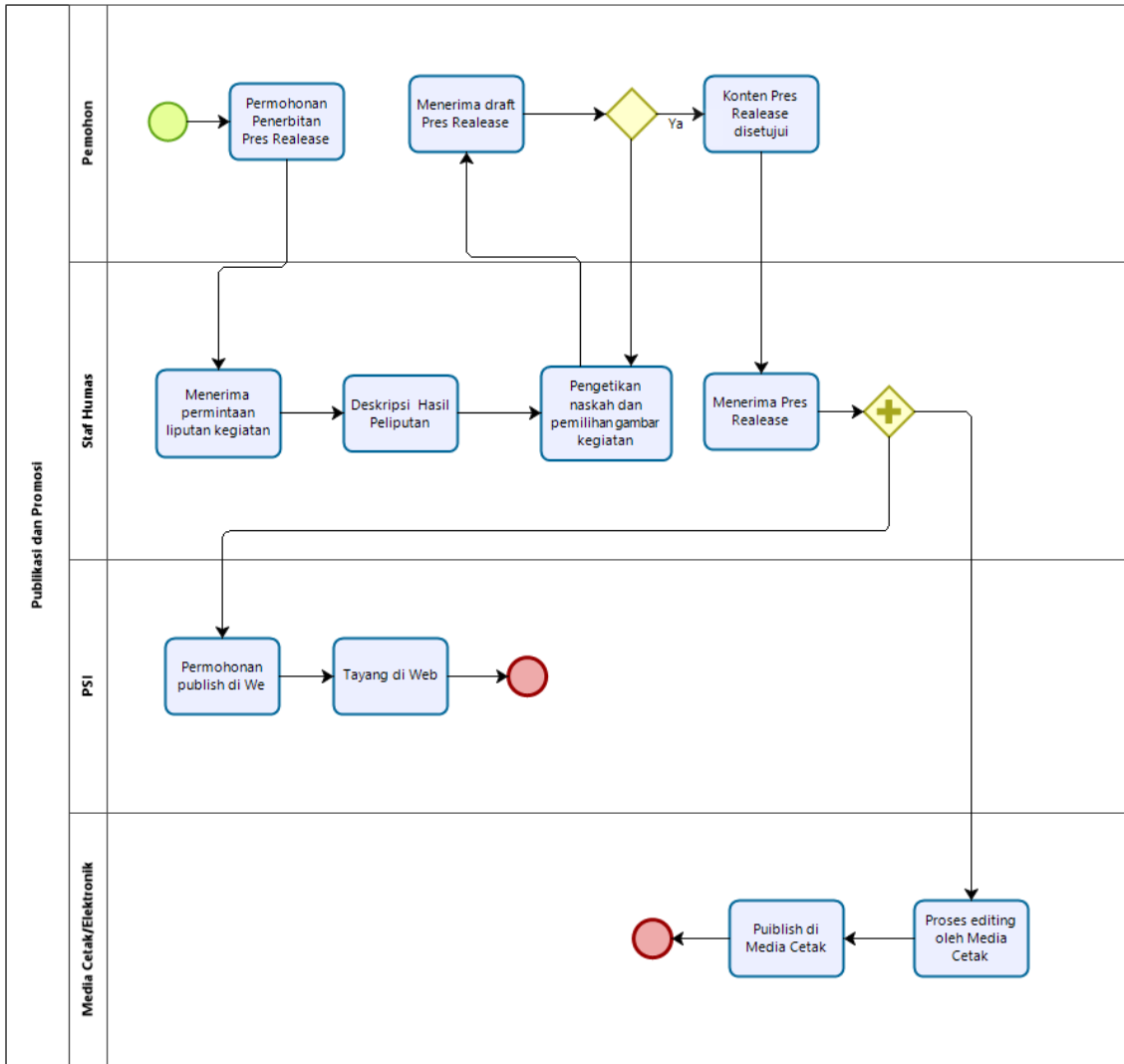

257. PENERBITAN WARTA

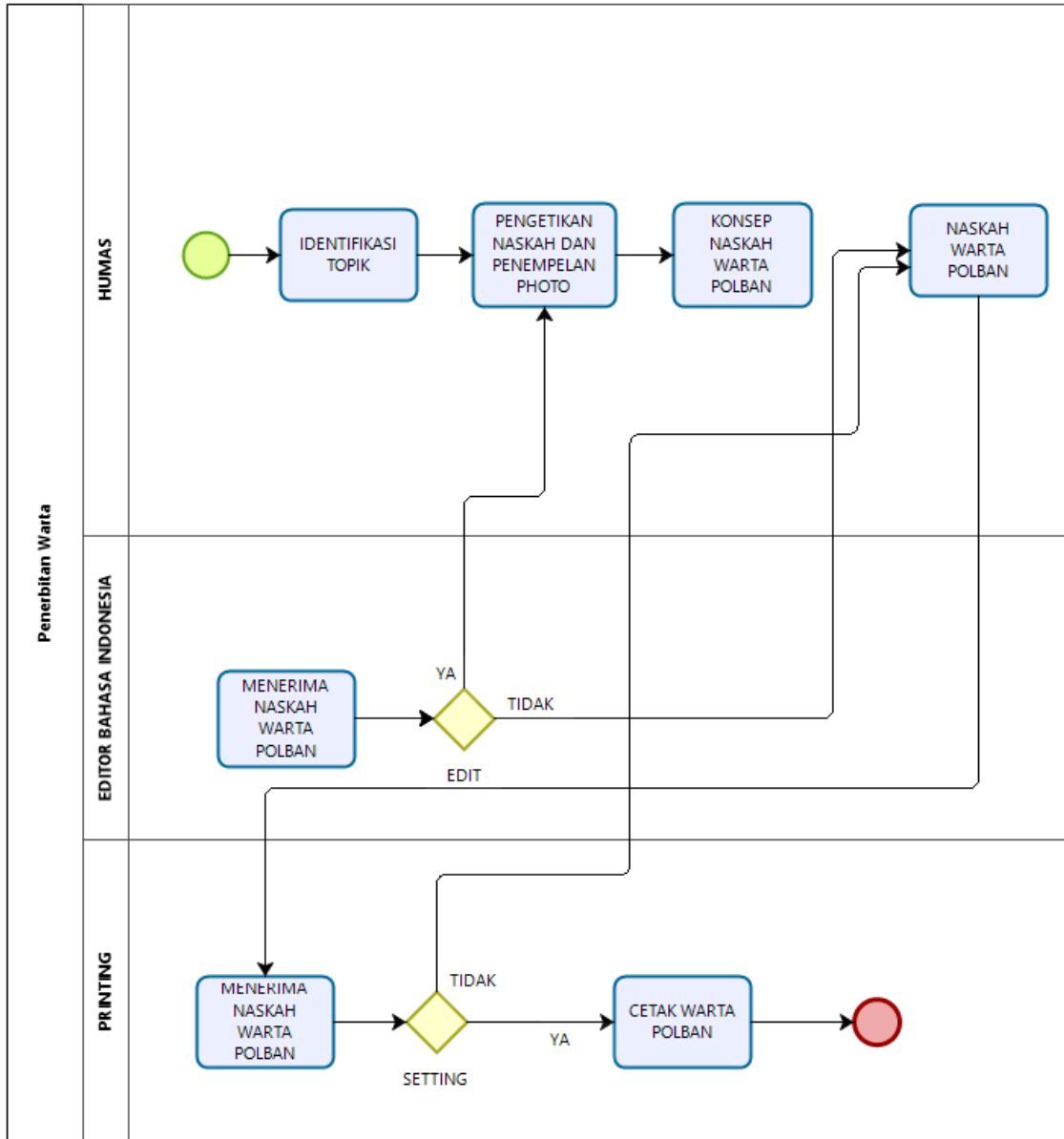

258. PENDISTRIBUSIAN WARTA

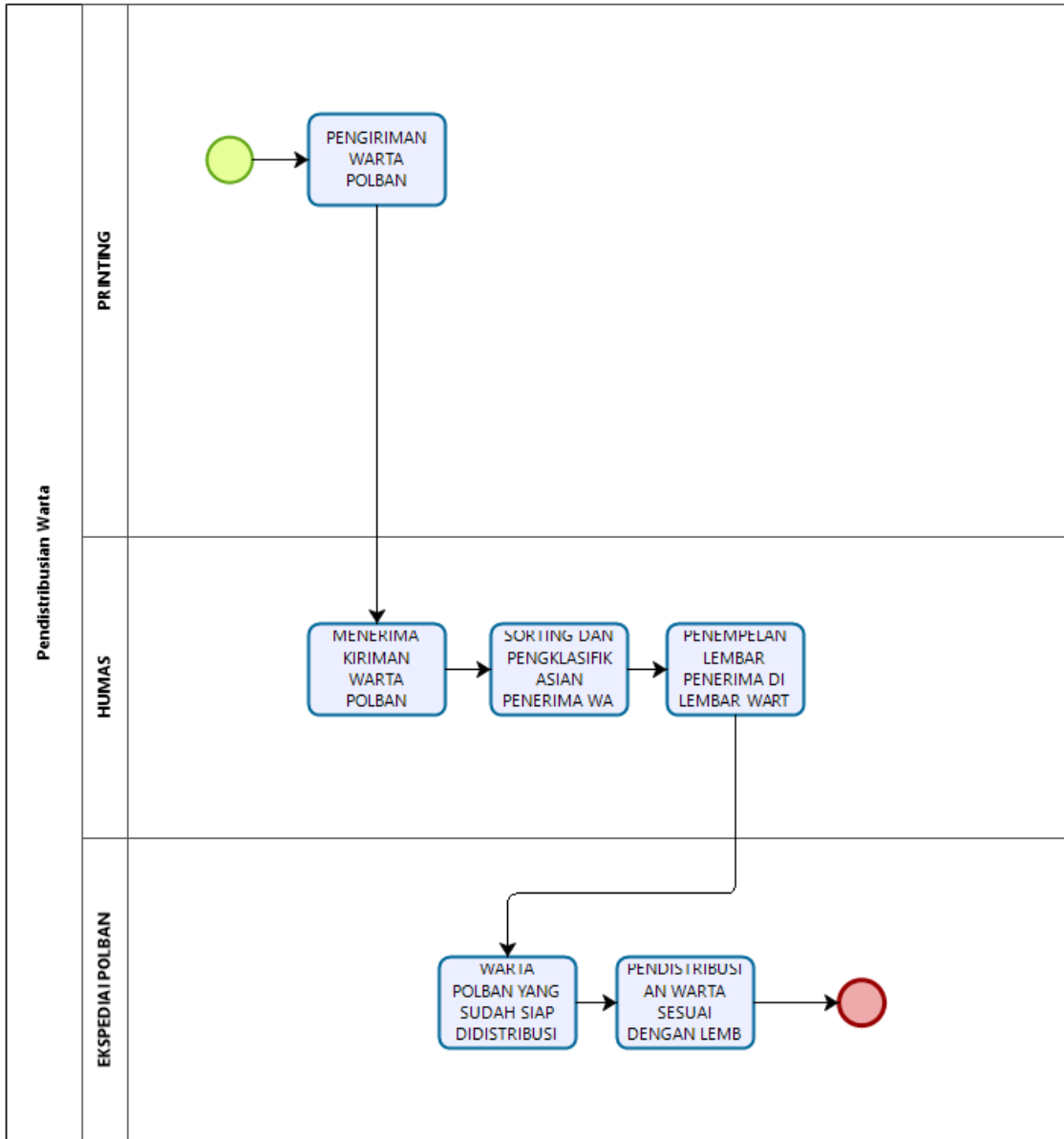

259. PROTOKOLER DAN PELAYANAN MASYARAKAT

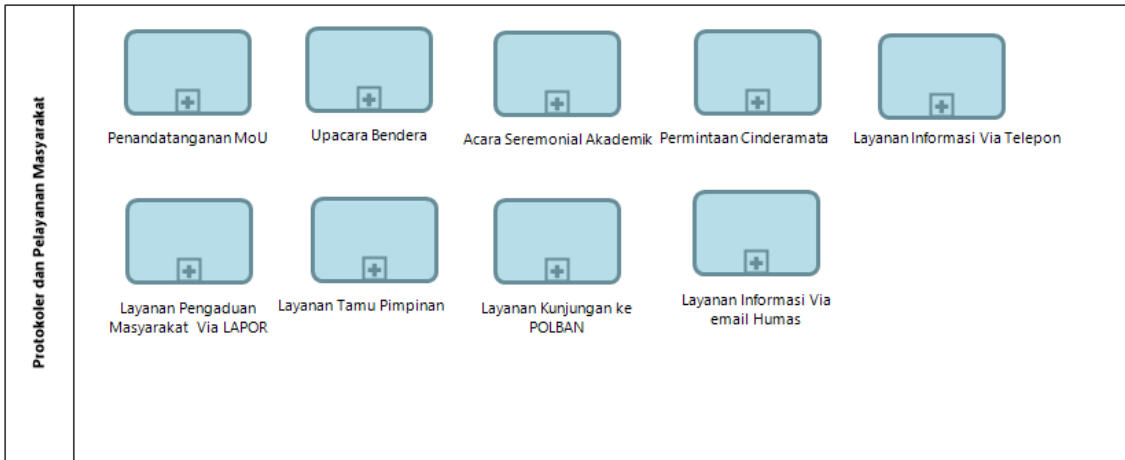

260. LAYANAN INFORMASI VIA EMAIL HUMAS

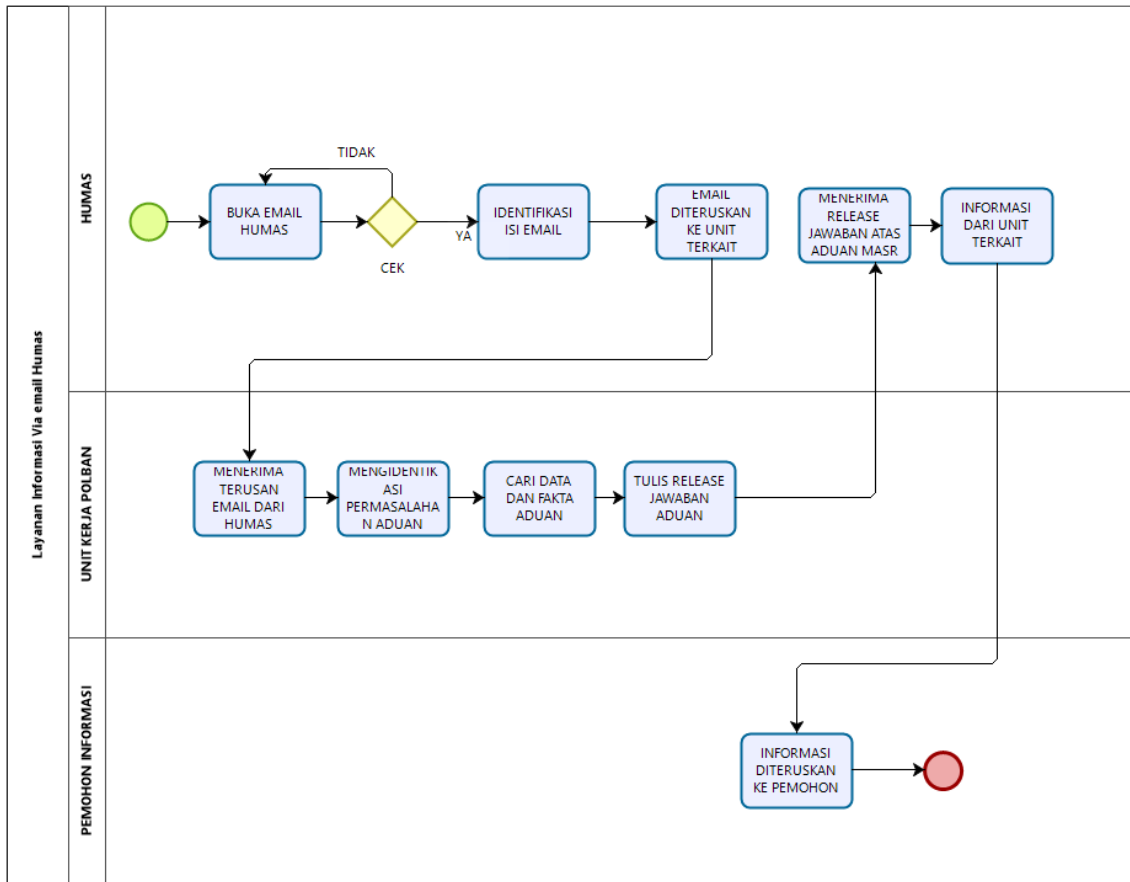

261. LAYANAN INFROMASI VIA TELEPON

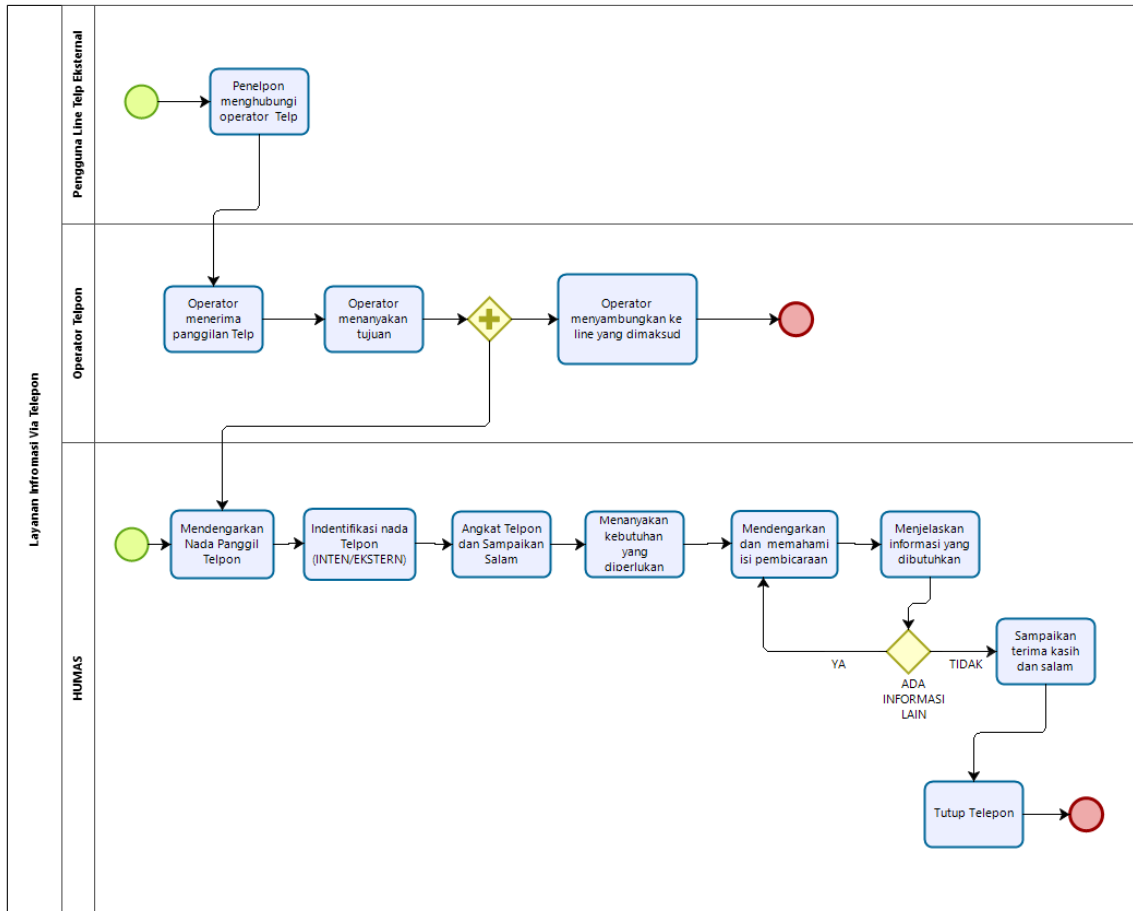

262. LAYANAN KUNJUNGAN KE POLBAN

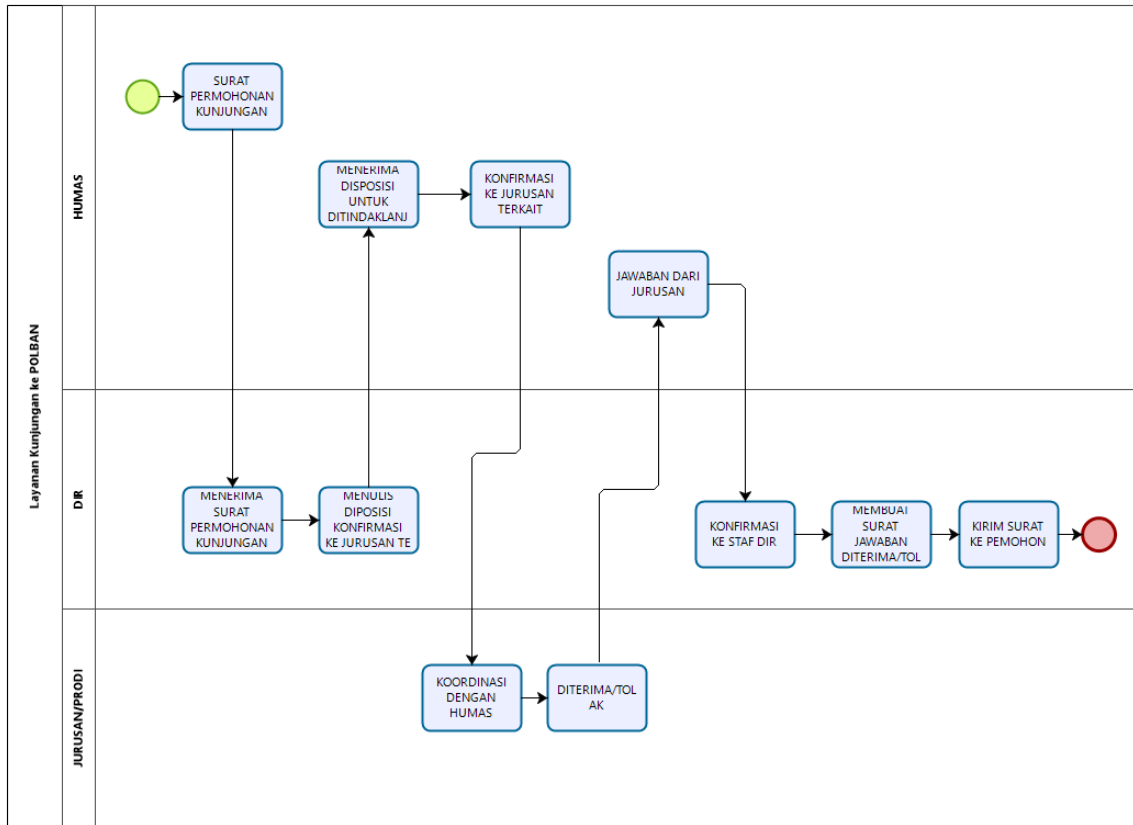

263. LAYANAN PENGADUAN MASYARAKAT VIA LAPOR

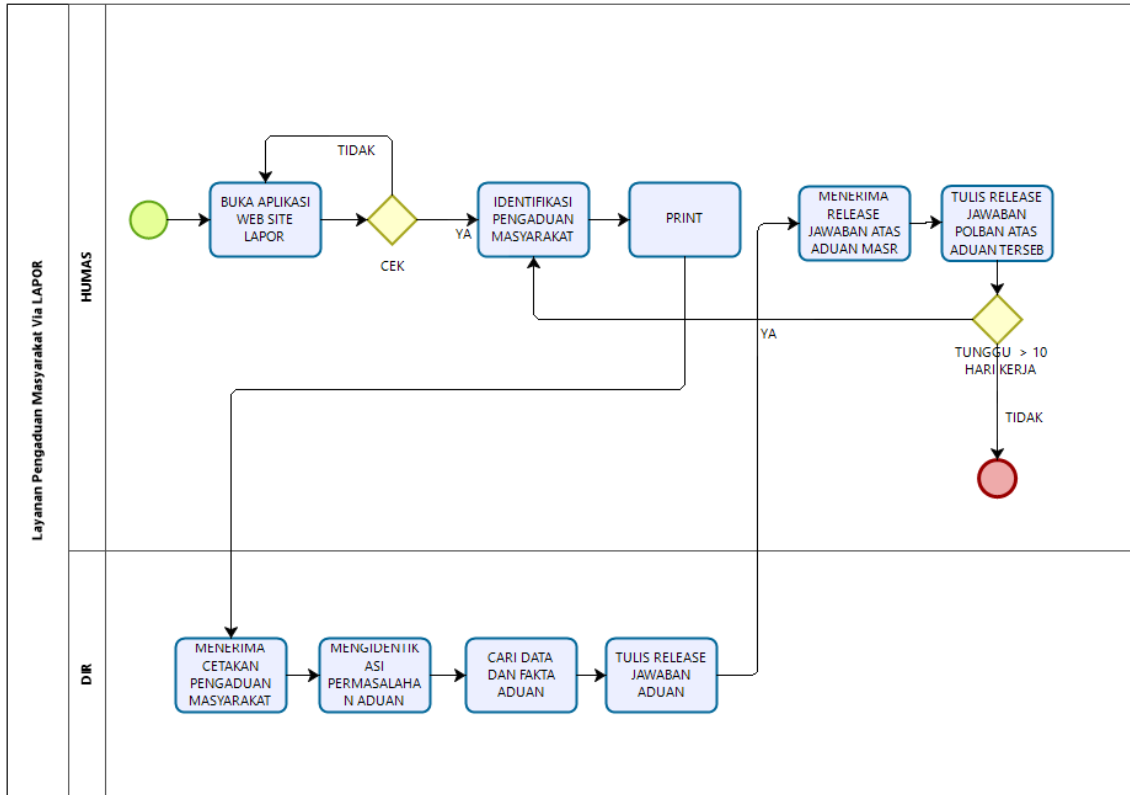

264. LAYANAN TEKNIS



265. UPT PERPUSTAKAAN



266. BEBAS MASALAH PERPUSTAKAAN

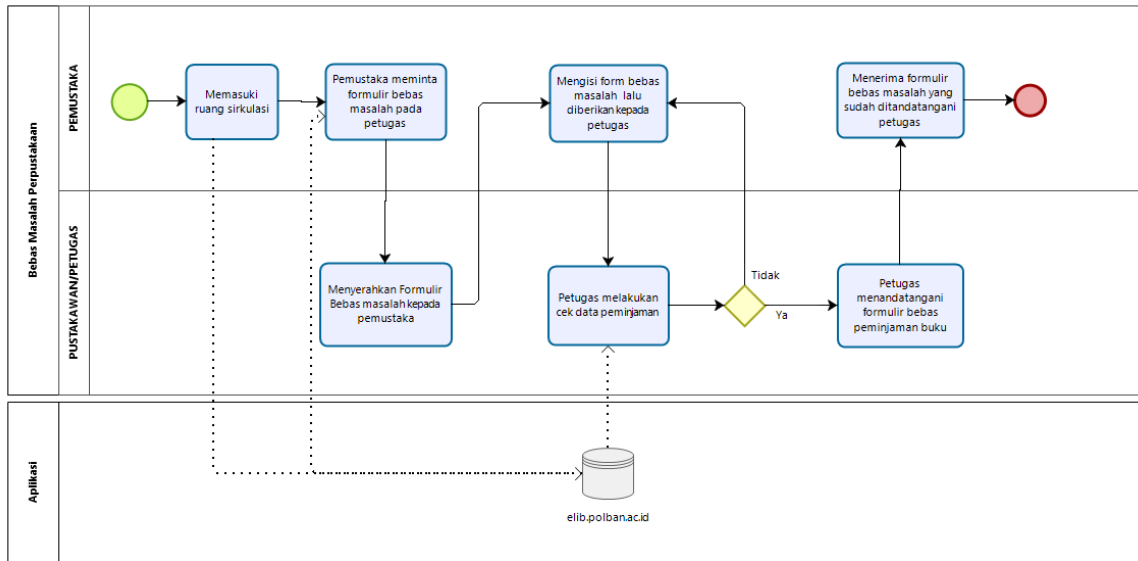

267. PEMINJAMAN BUKU

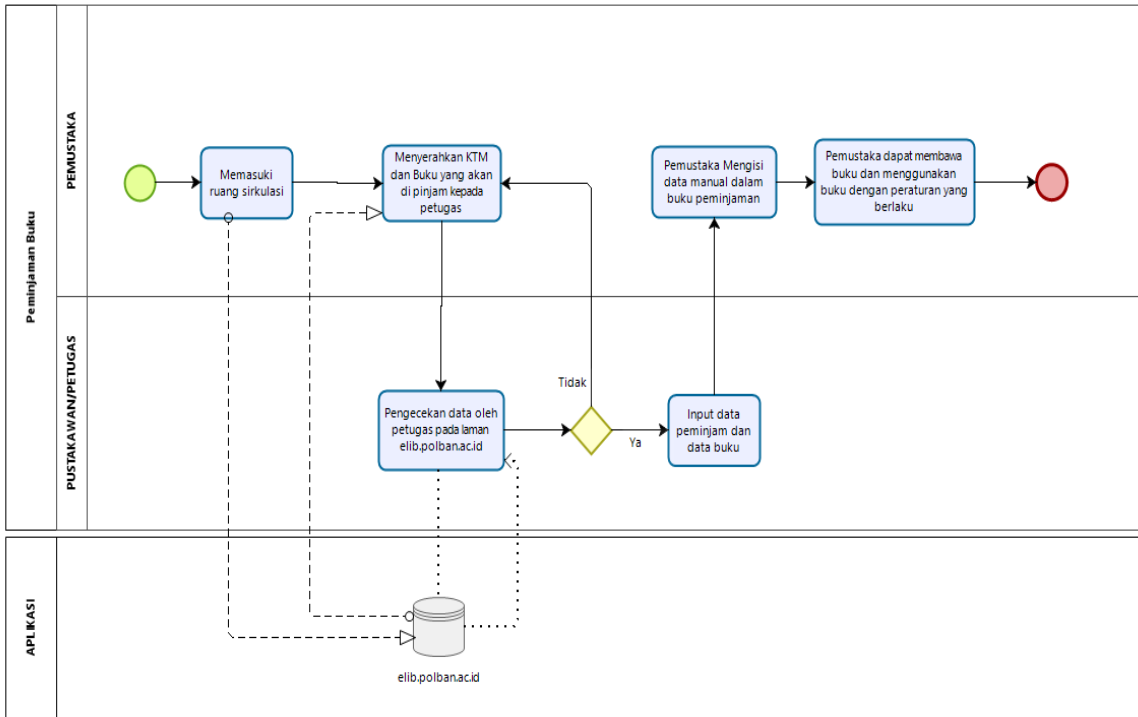

268. PENGEMBALIAN BUKU

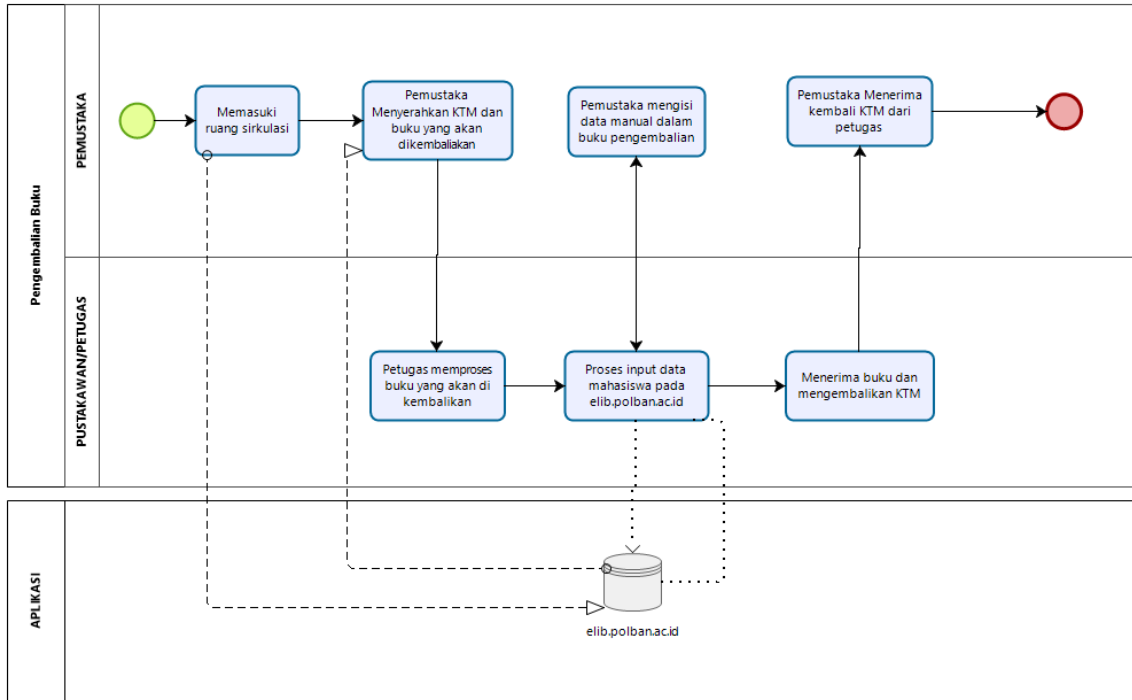

269. PENGGUNAAN RUANG AKSES DIGITAL

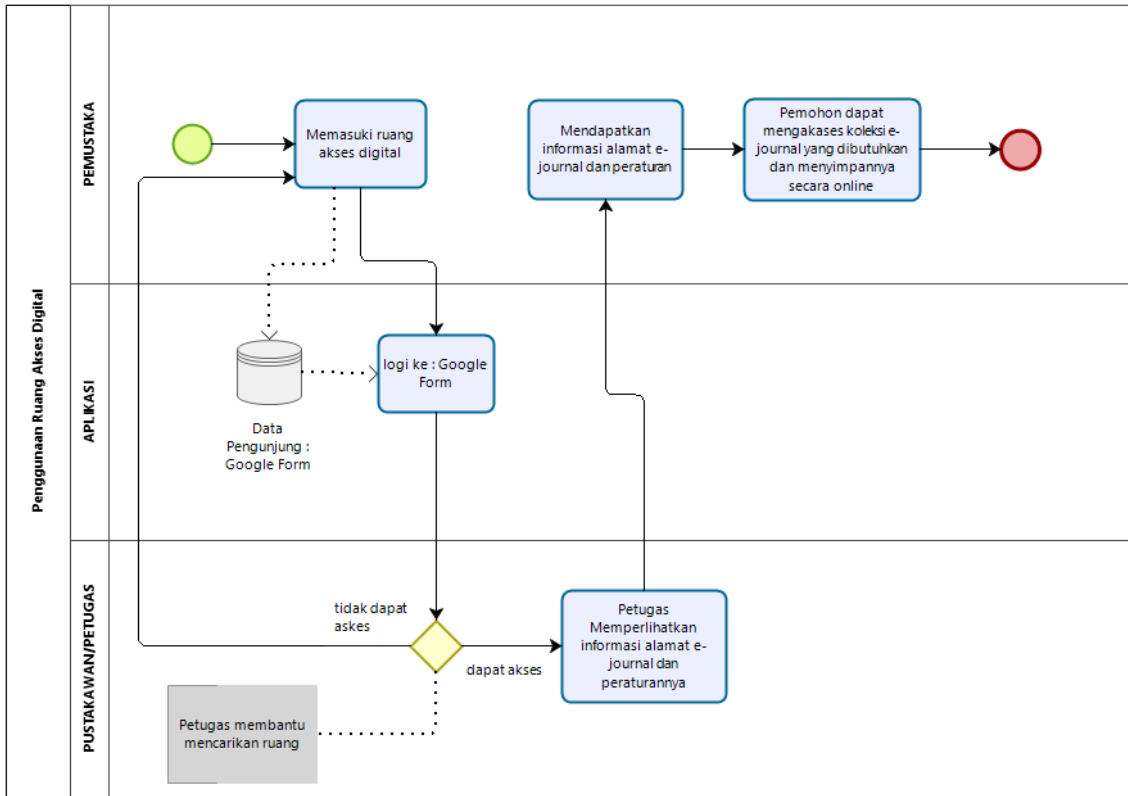

270. PENGGUNAAN RUANGAN TELECONFERENCE

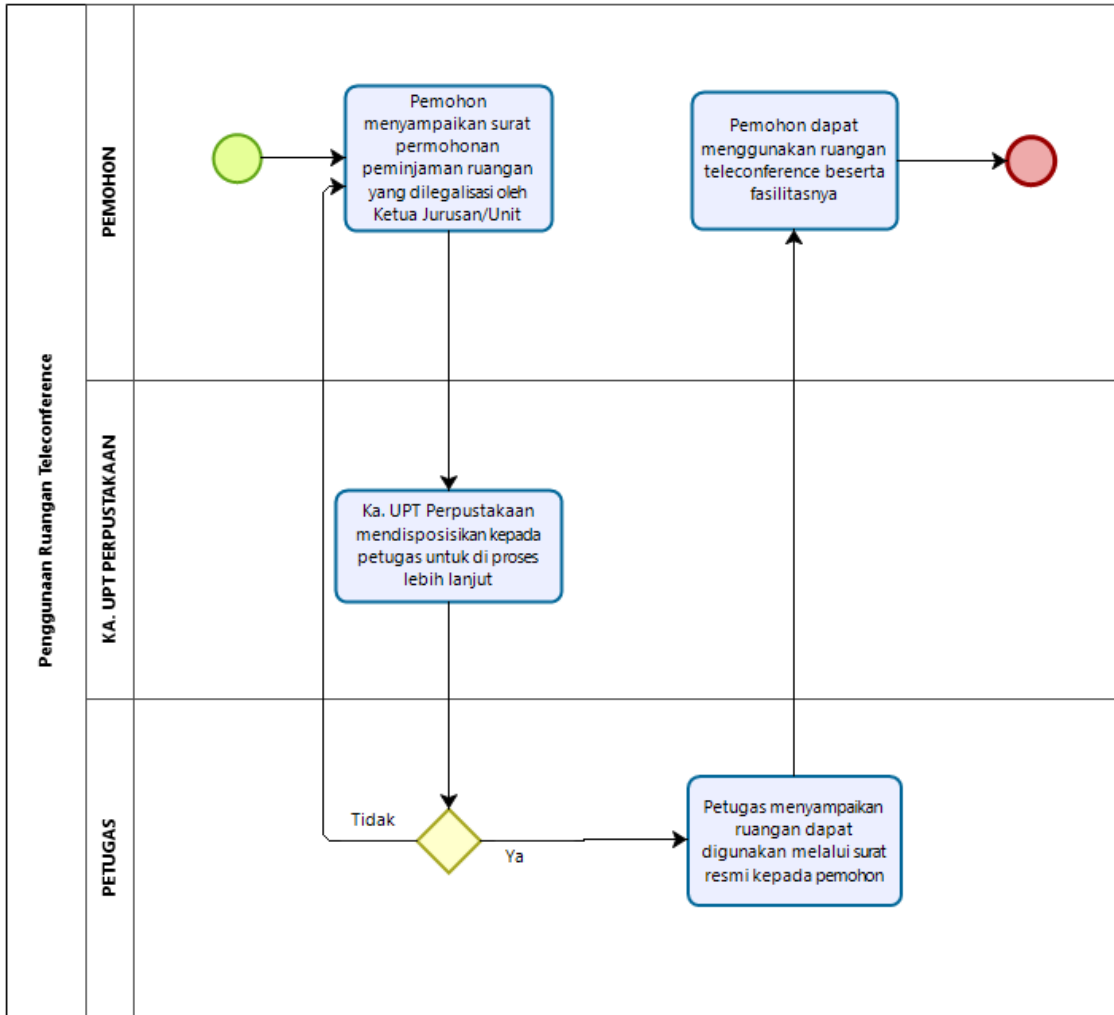

271. PERPANJANGAN KEANGGOTAAN

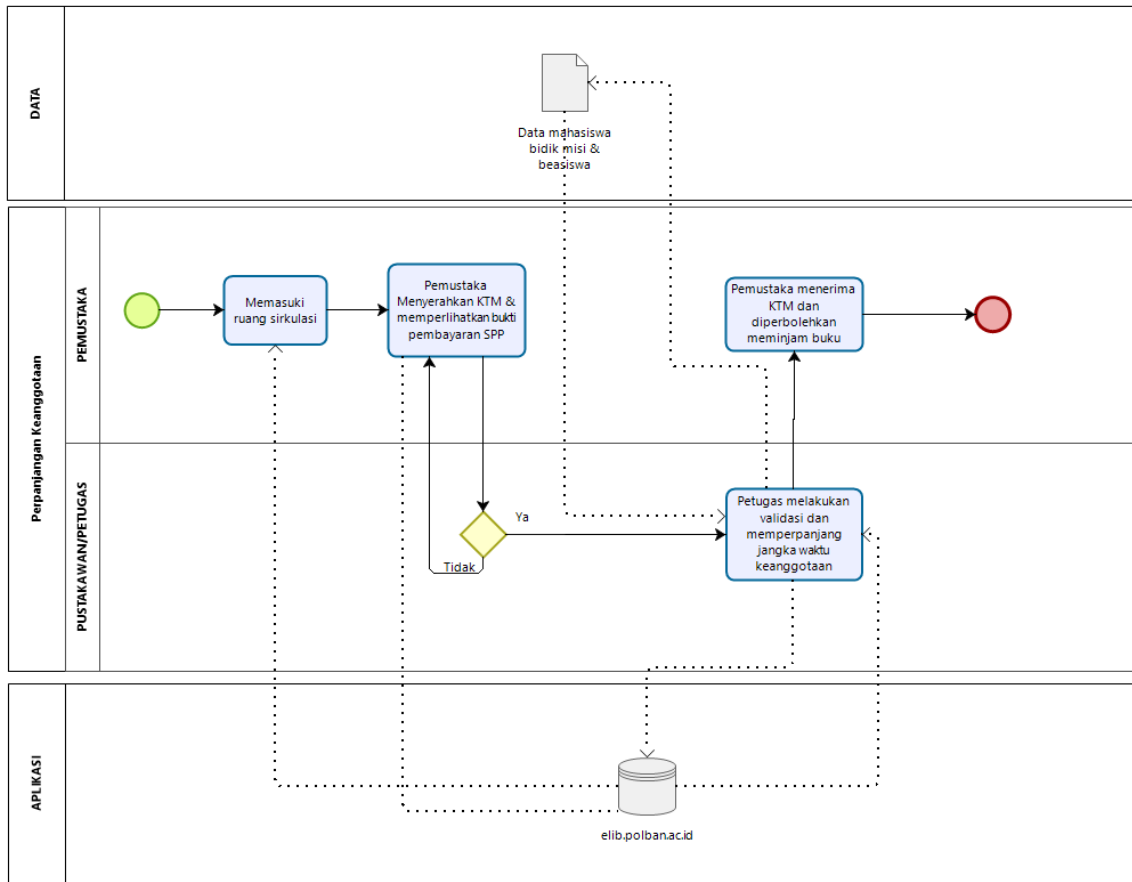

272. REFERENSI BUKU PUSTAKA

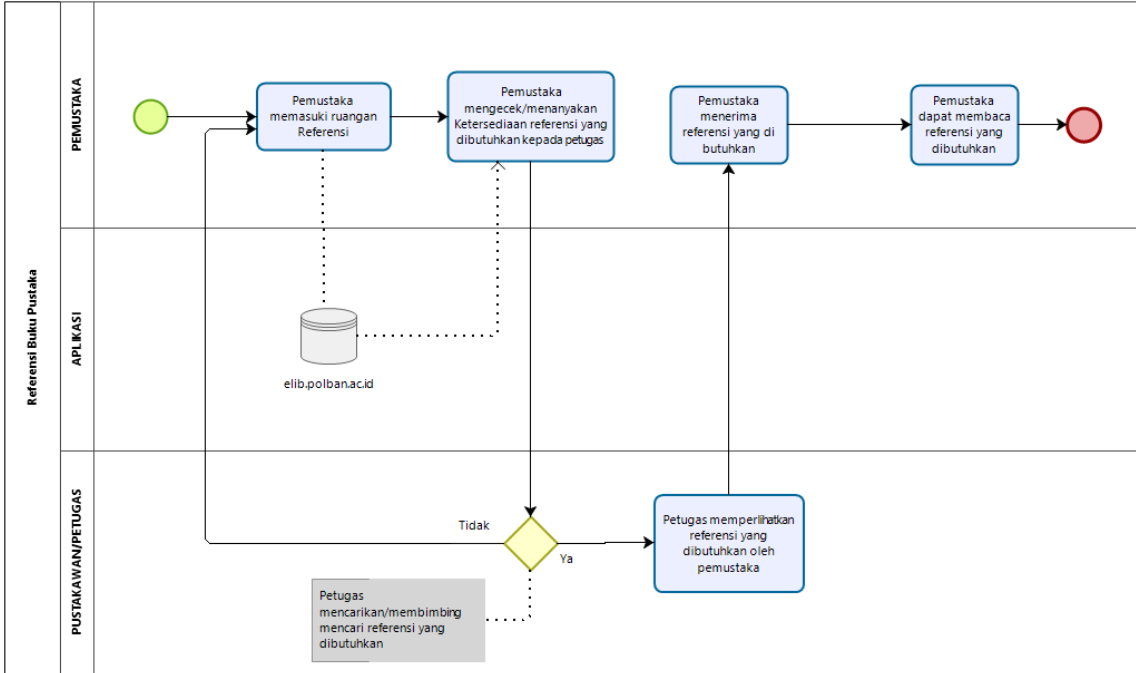

Powered by bizagi Modeler

273. UPT. KOMPUTER (UPTK)

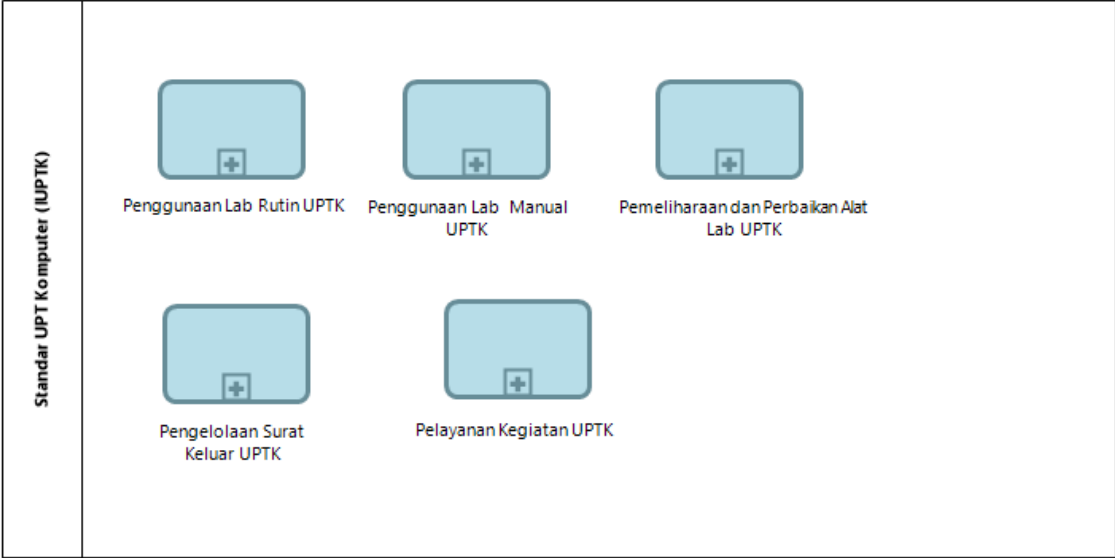

274. PELAYANAN KEGIATAN UPTK

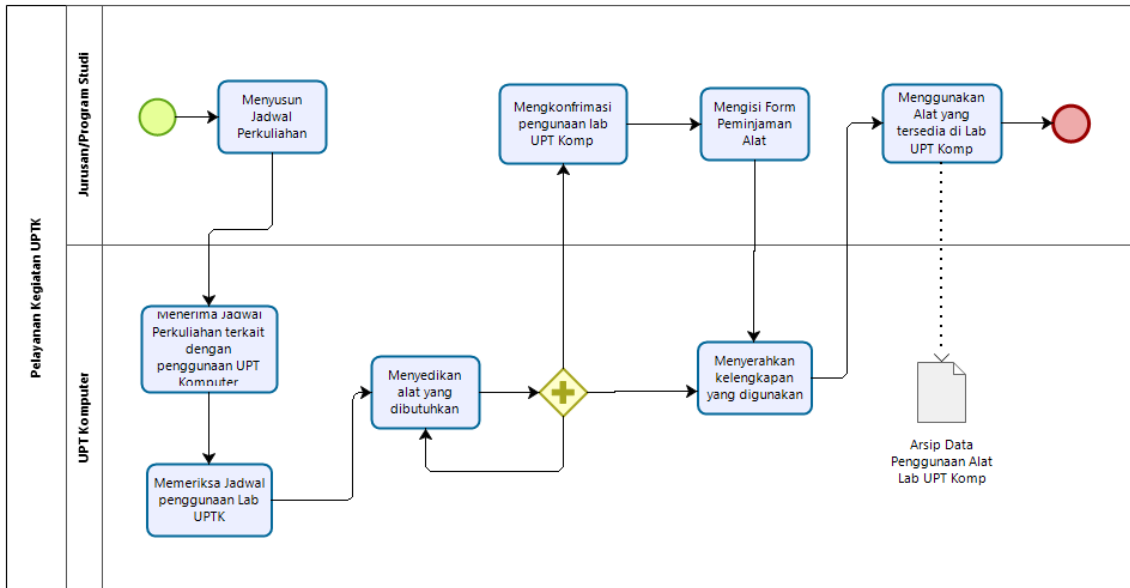

275. PEMELIHARAAN DAN PERBAIKAN ALAT LAB UPTK

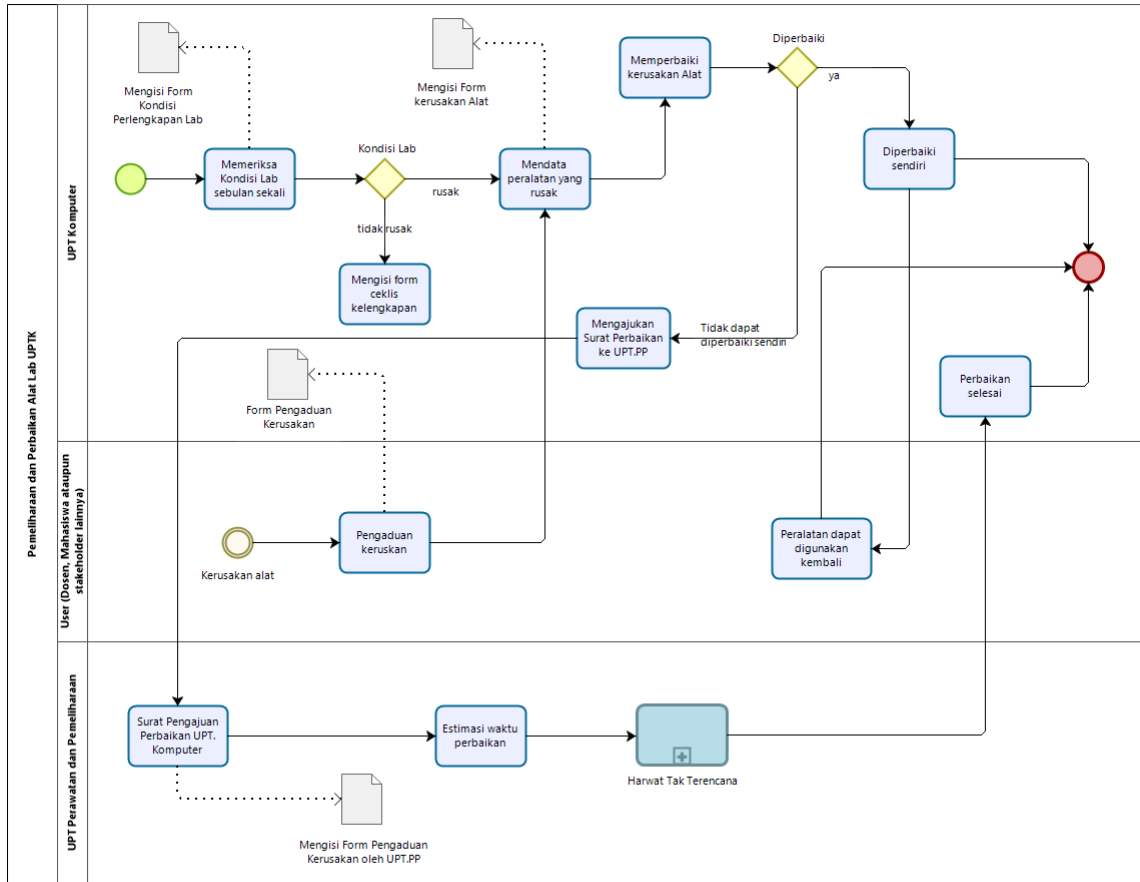

276. PENGGUNAAN LAB RUTIN UPTK

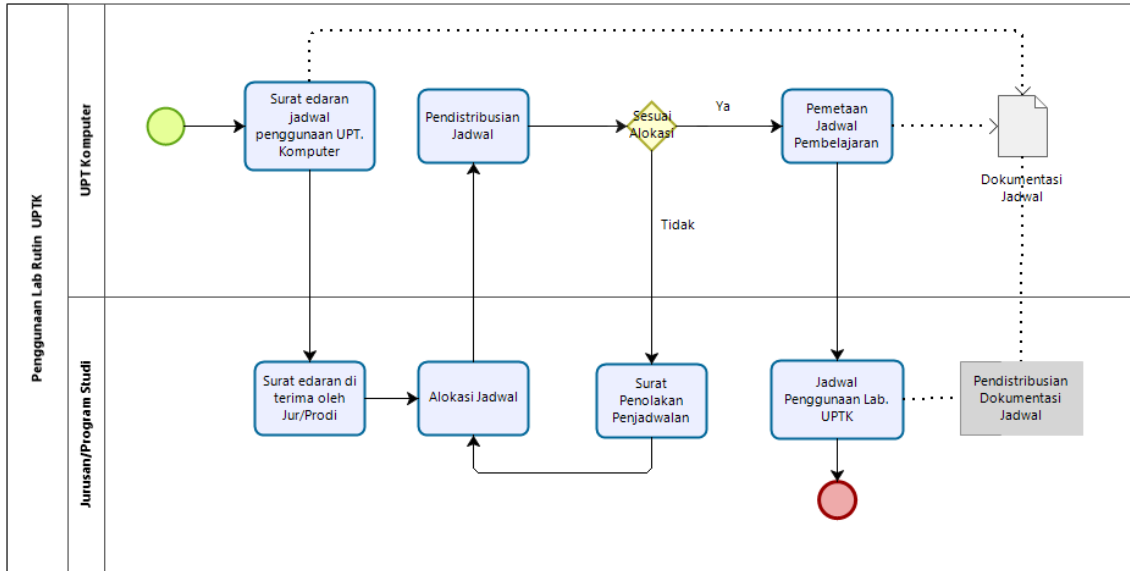

Powered by
bizagi
Modeler

277. PENGGUNAAN LAB MANUAL UPTK

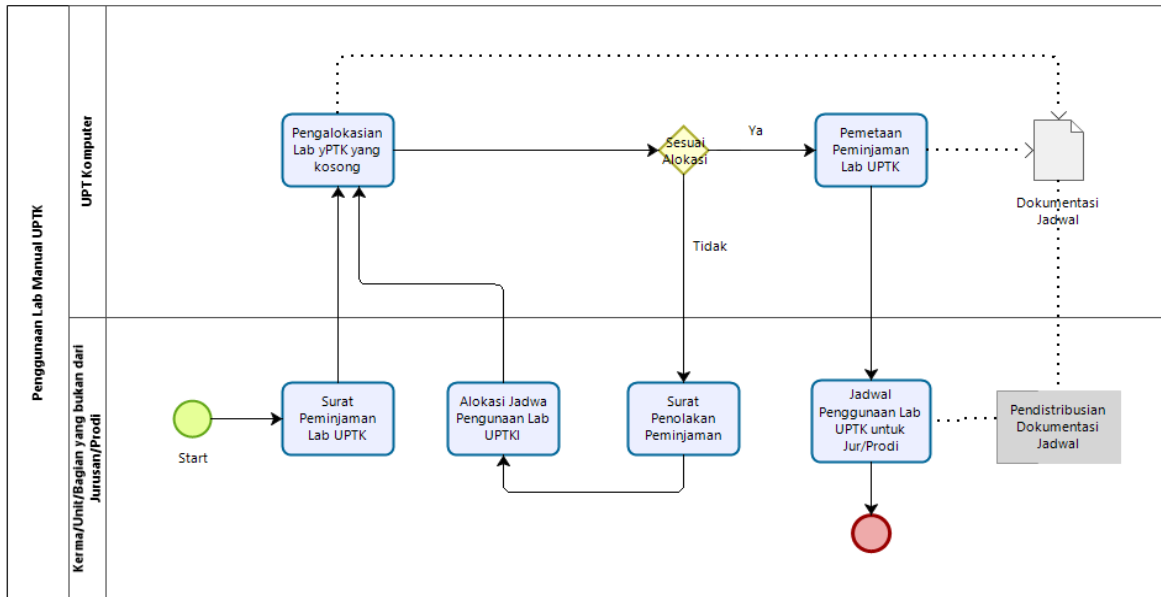

278. UPT BAHASA

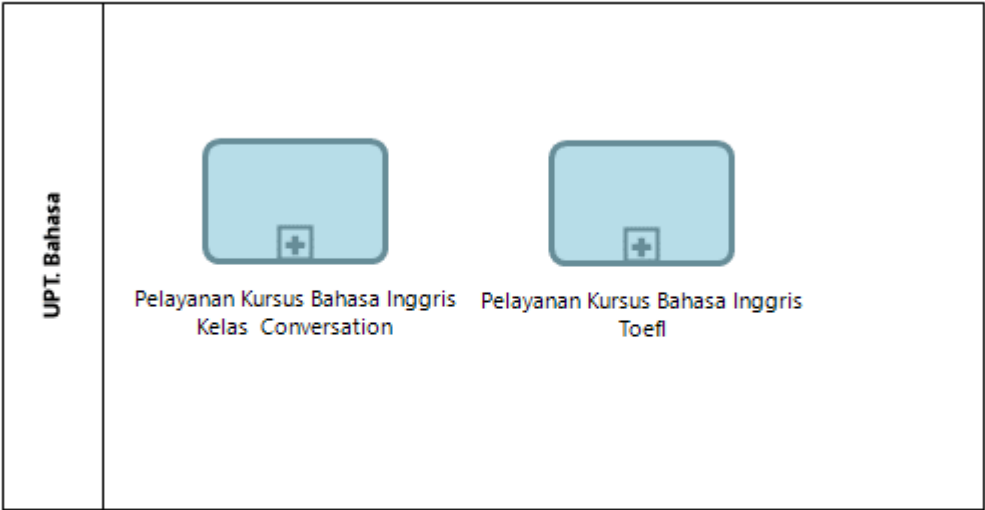

279. PELAYANAN KURSUS BAHASA INGGRIS KELAS CONVERSATION.

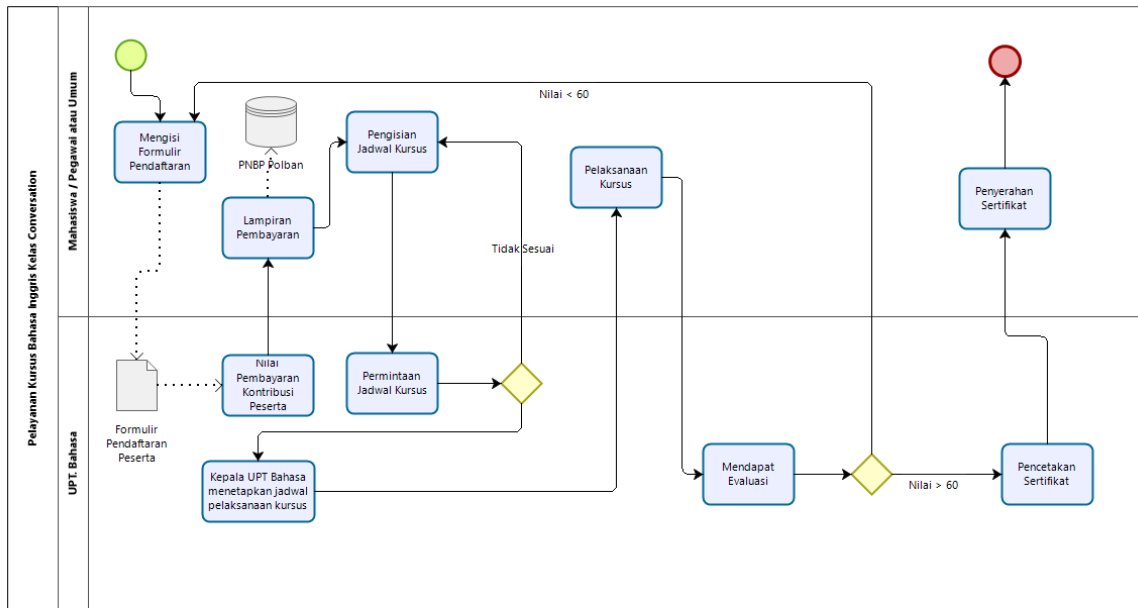

Powered by
bizagi
Modeler

280. PELAYANAN KURSUS BAHASA INGGRIS TOEFL

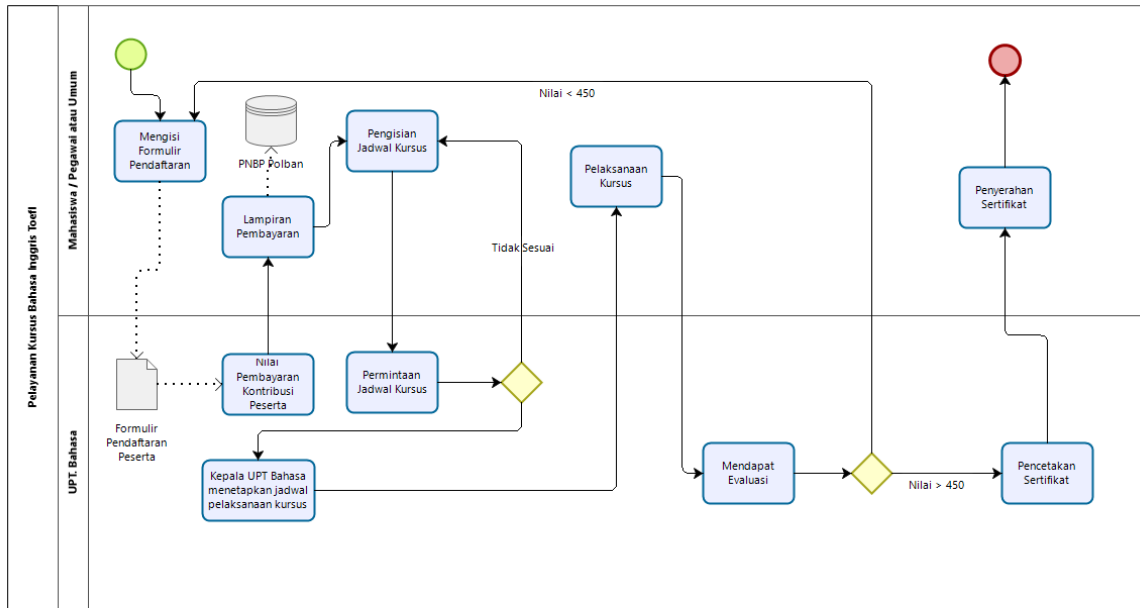

281. UPT STUDIO GAMBAR (SGB)



282. PELAYANAN KEGIATAN UPT STUDIO GAMBAR

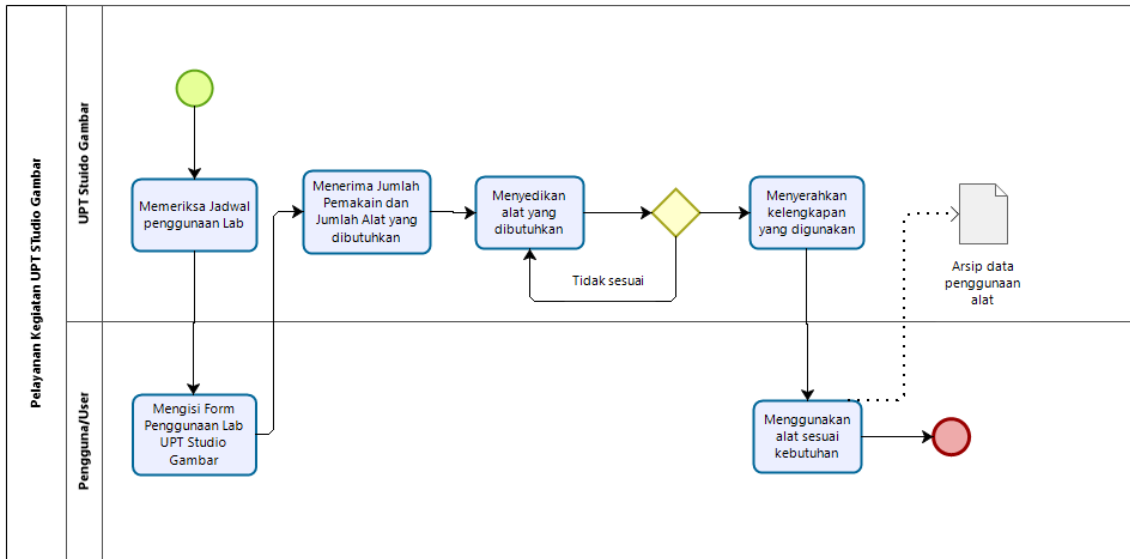

283. PEMELIHARAAN DAN PERBAIKAN ALAT LAB UPT SGB

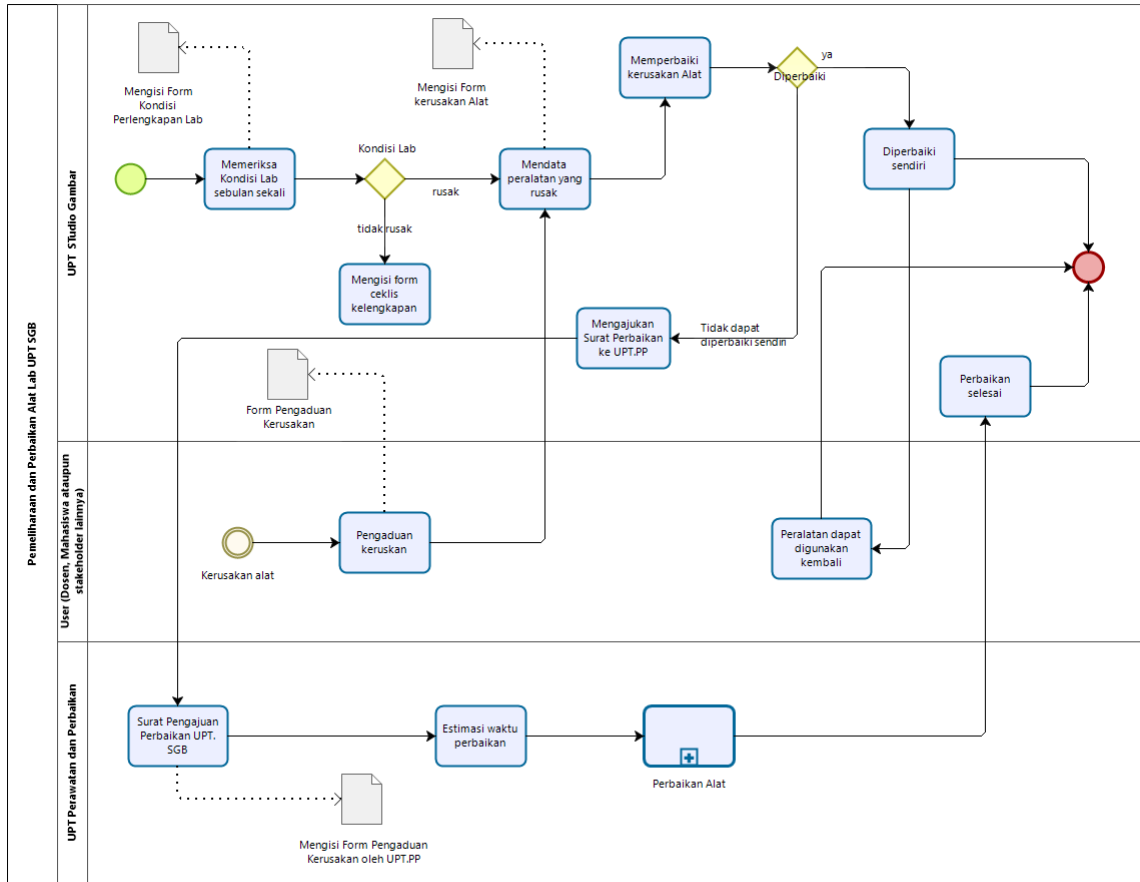

284. PENGGUNAAN LAB SGB TIDAK RUTIN

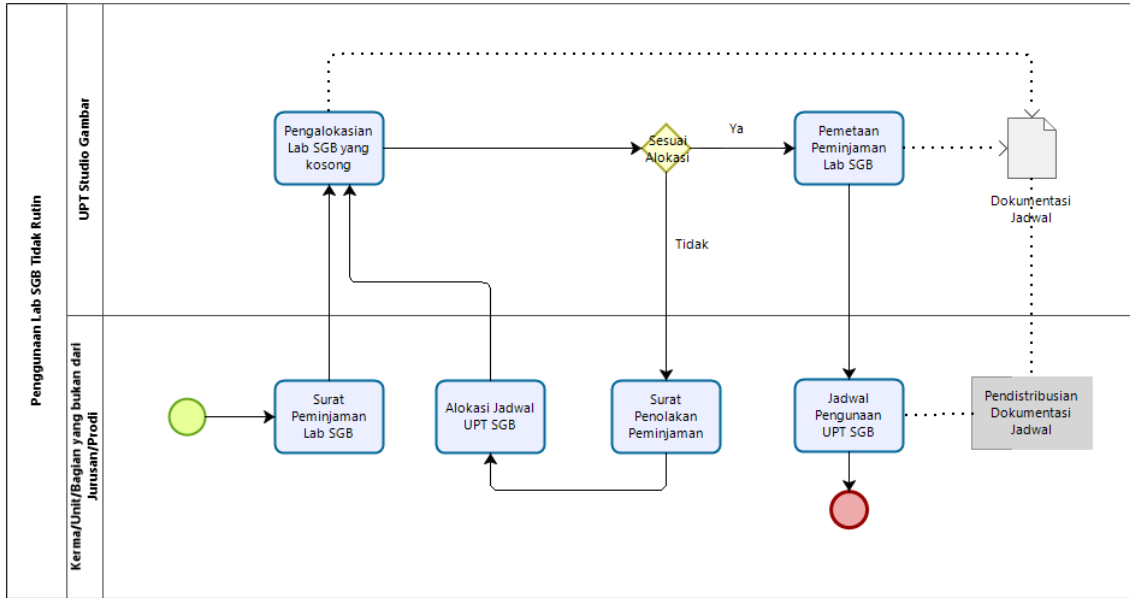

285. PENGGUNAAN LAB SGB RUTIN

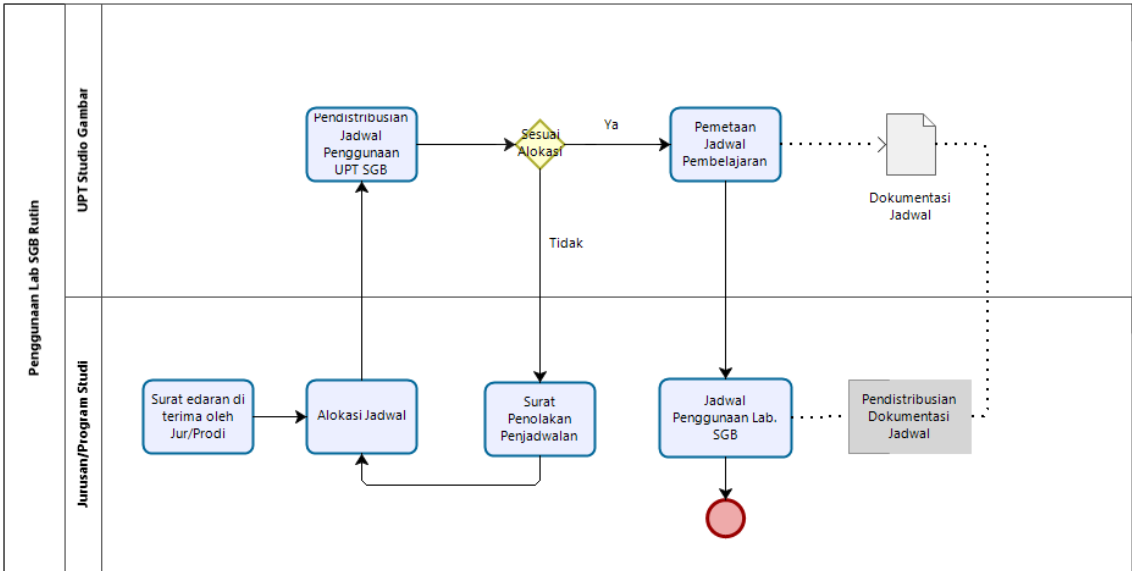

286. UPT LAYANAN KESEHATAN



287. PELAYANAN KESEHATAN PASIEN

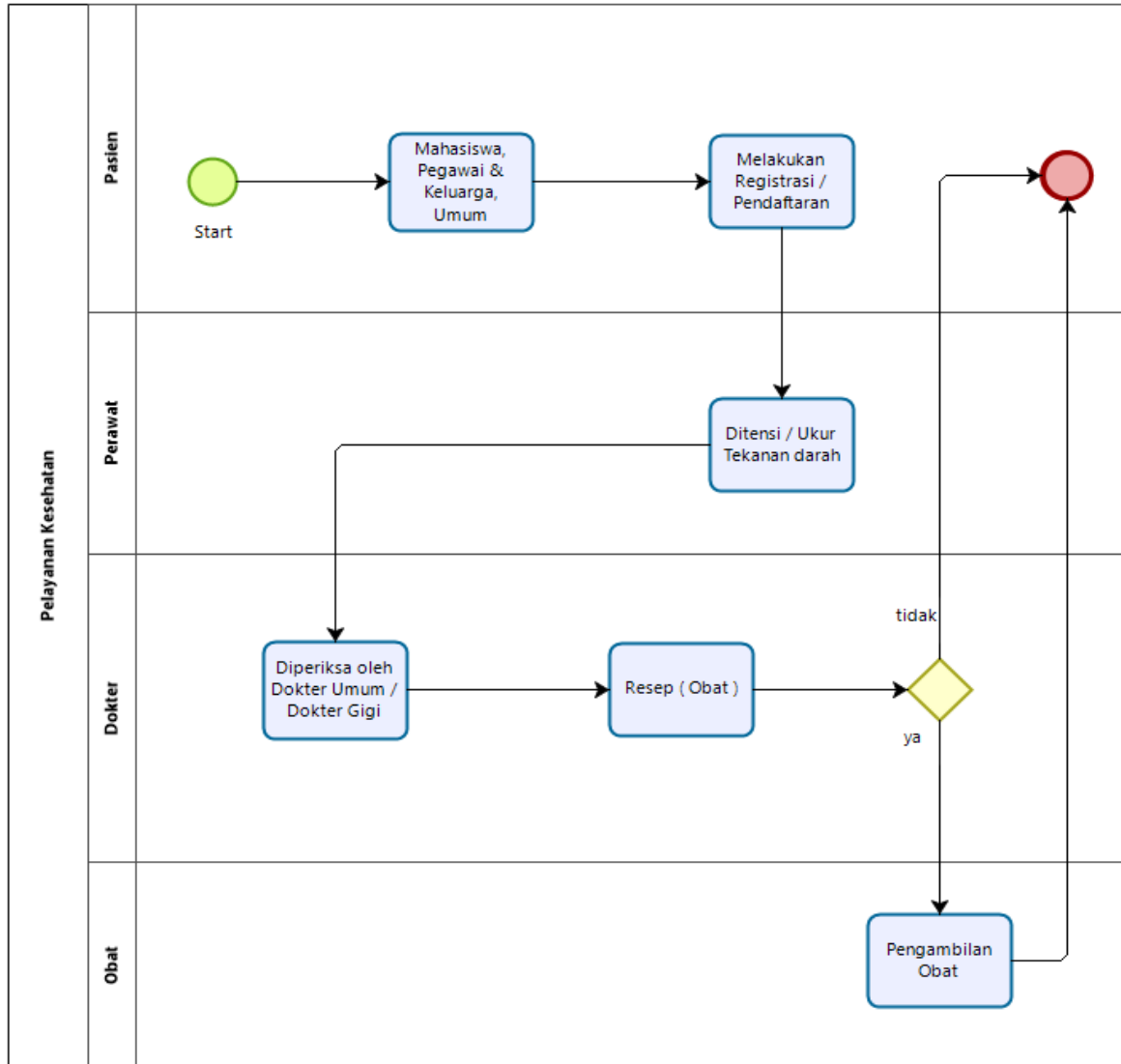

288. LAYANAN ADMINISTRASI UPT LK

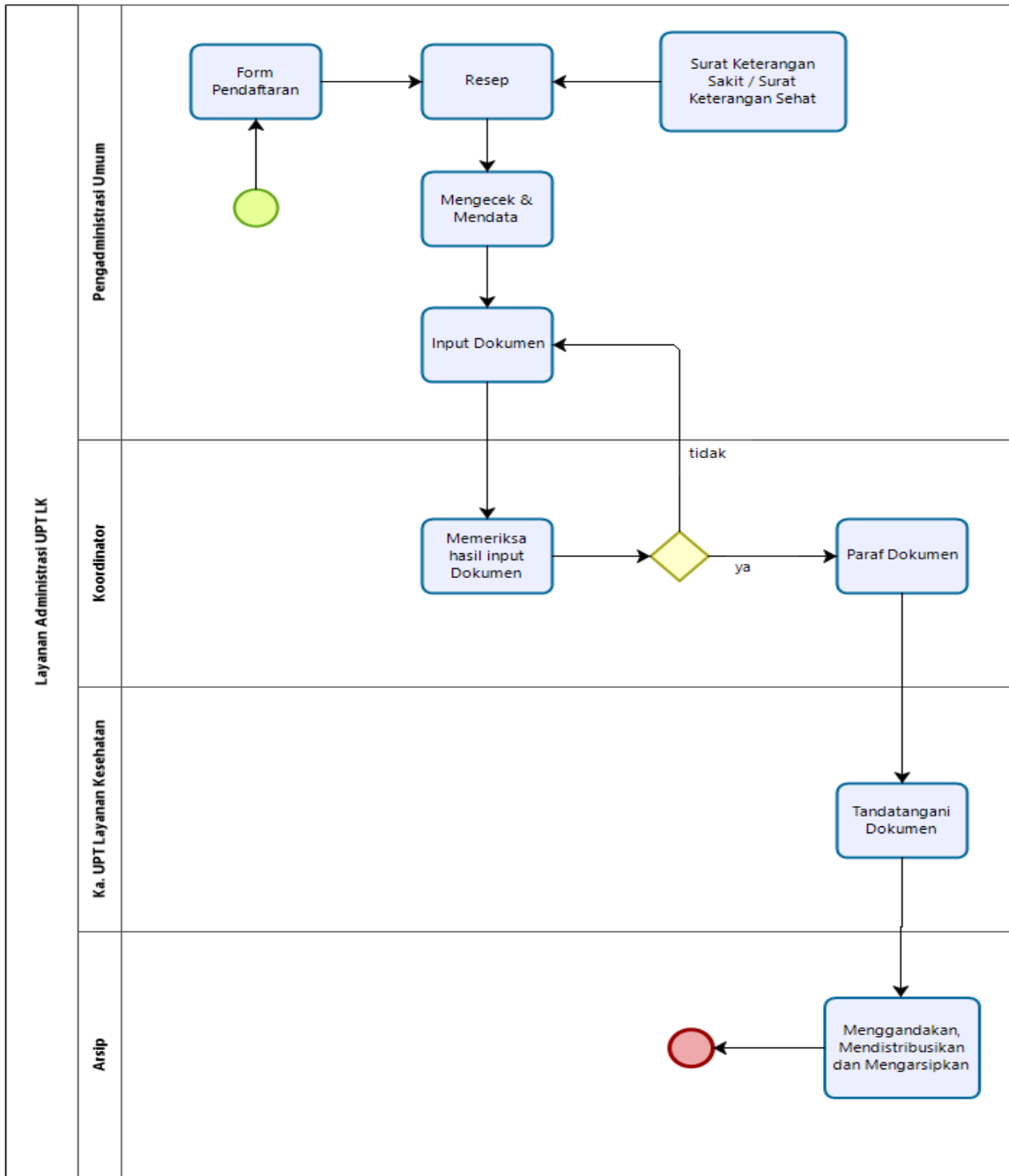

289. PEMINJAMAN ALAT UPT LK

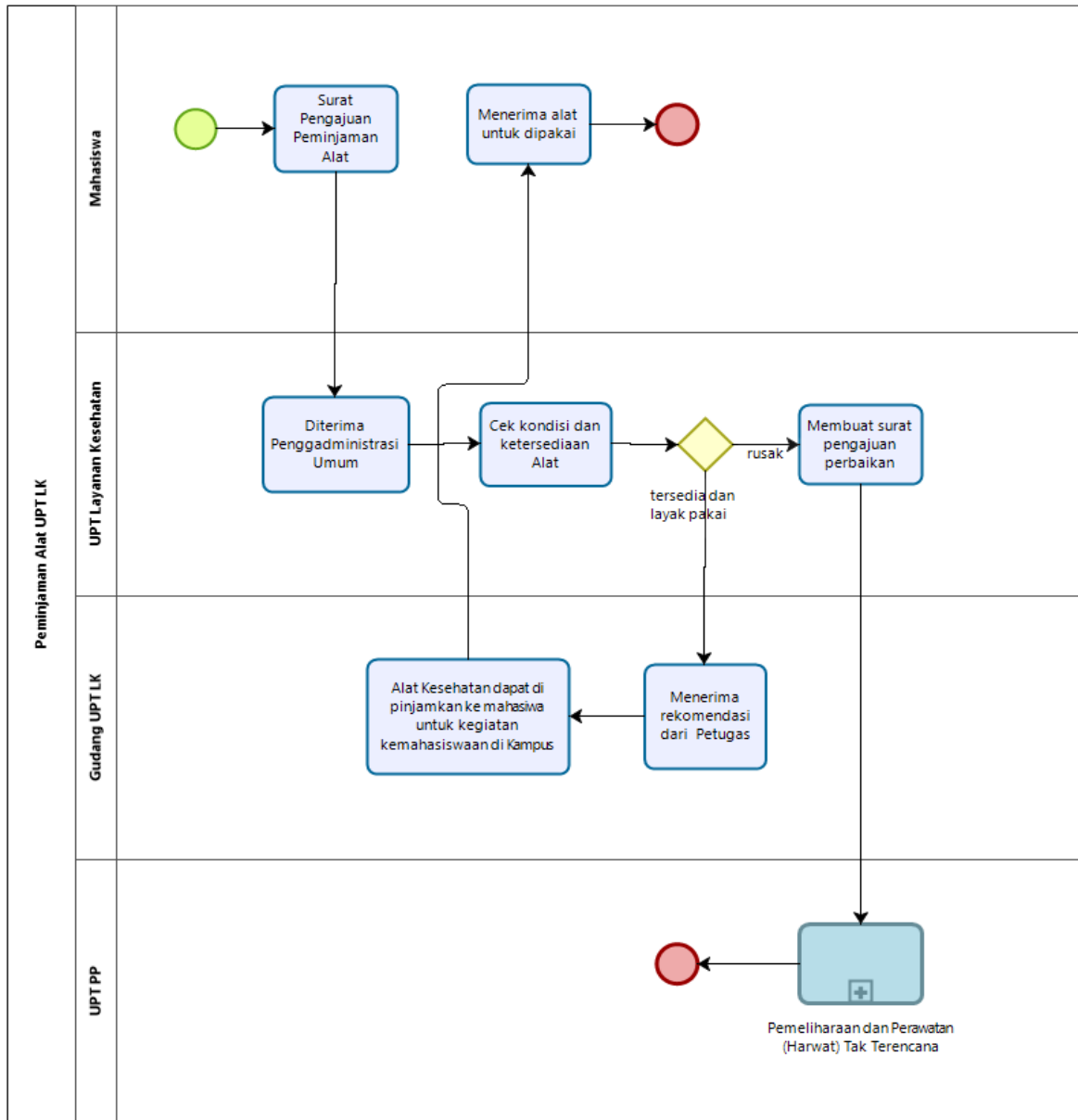

290. LAYANAN PERAWATAN DAN PEMELIHARAAN



Powered by
bizagi
Modeler

291. PEMELIHARAAN DAN PERAWATAN (HARWAT) TAK TERENCANA

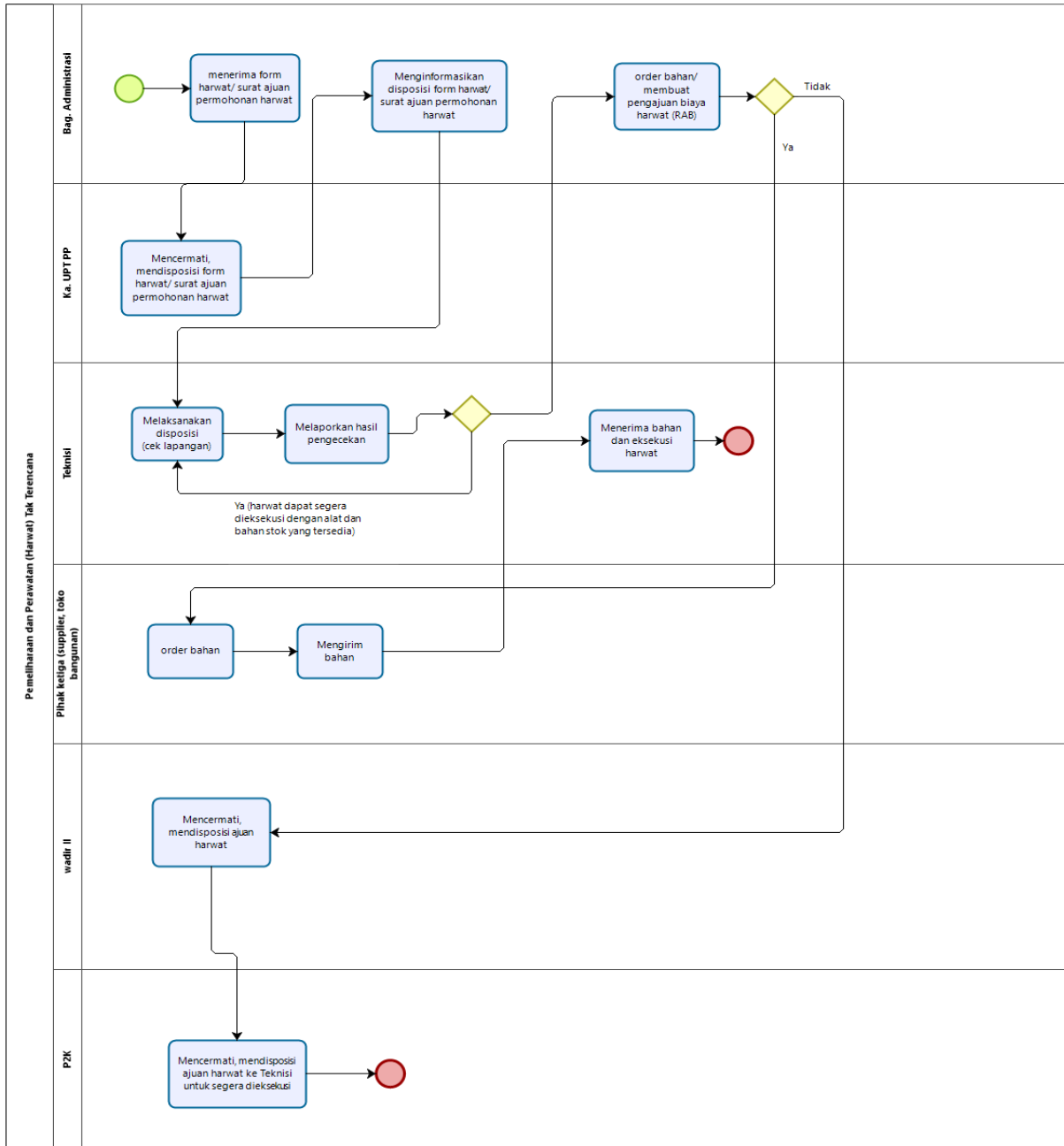

292. PEMELIHARAAN DAN PERAWATAN (HARWAT) TERENCANA

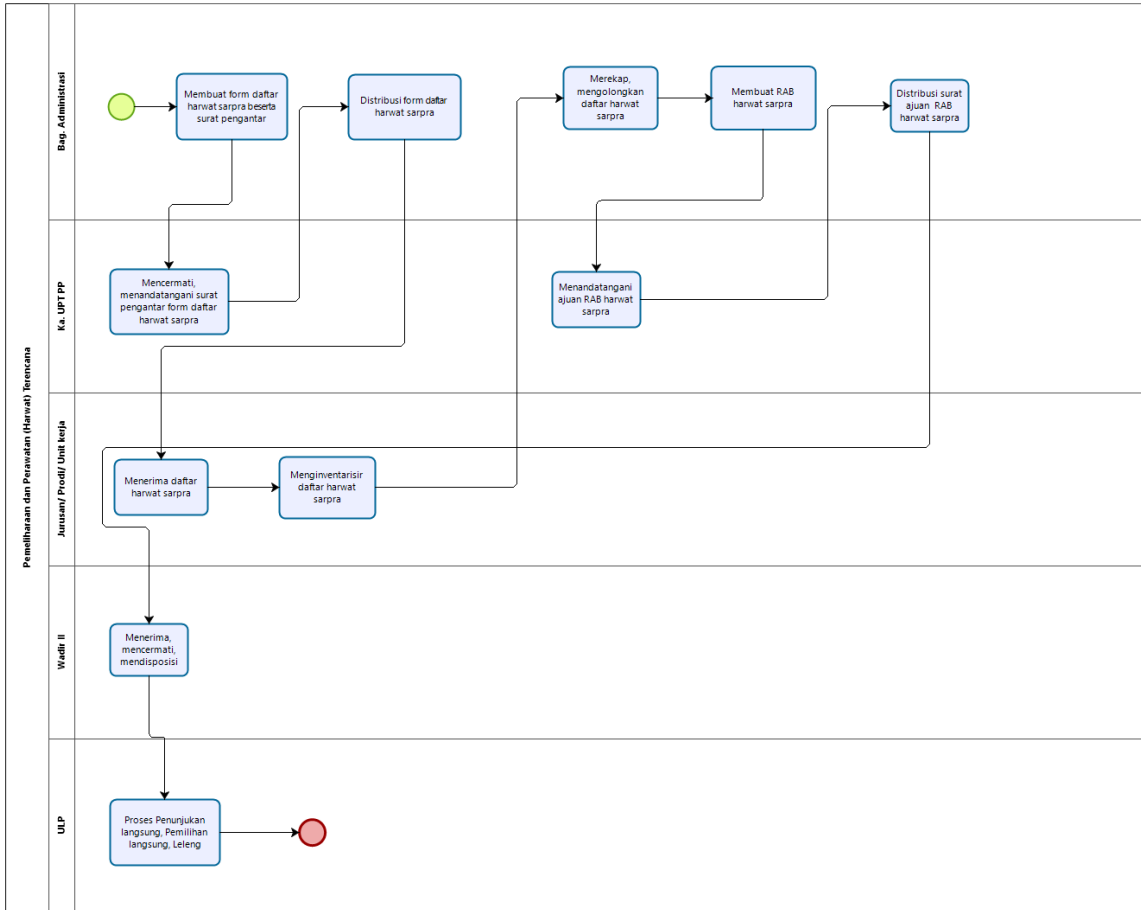

293. PEMELIHARAAN DAN PERBAIKAN ALAT LAB

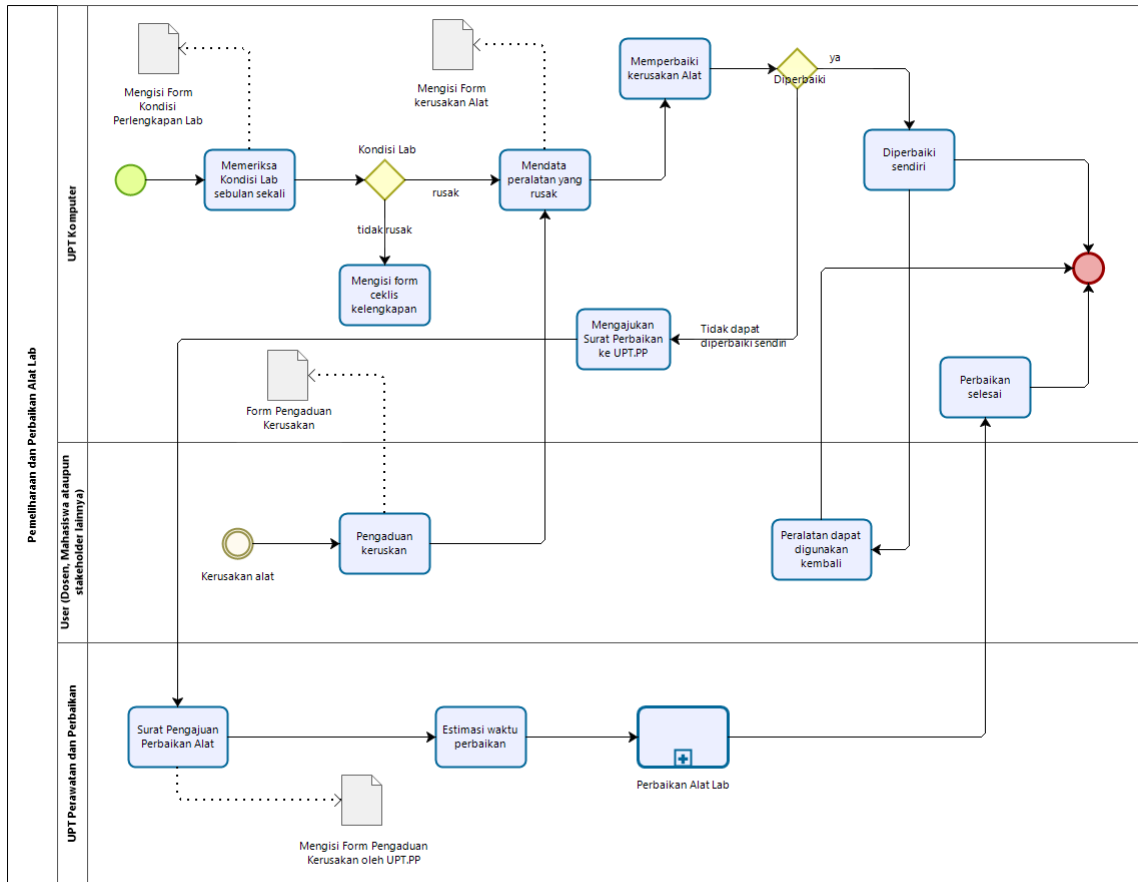

294. PERBAIKAN ALAT DI LABORATORIUM

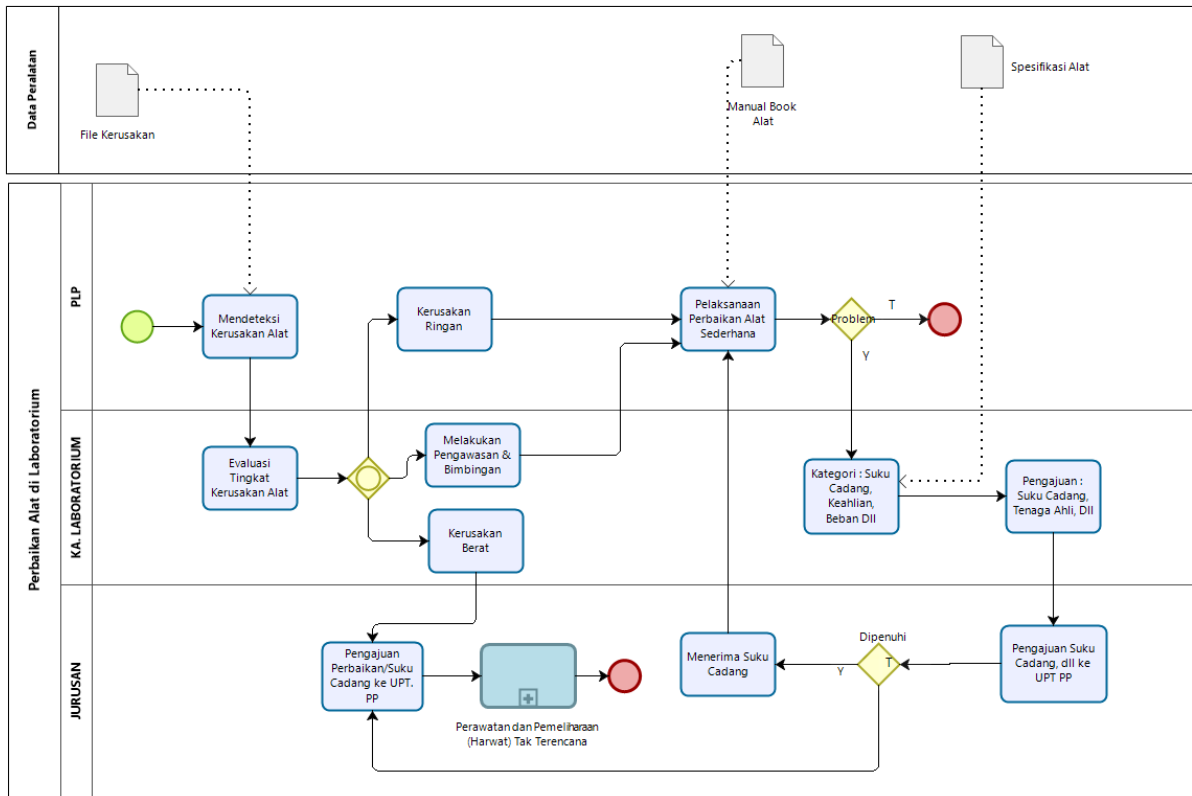

Powered by
bizagi
Modeler

296. PENGOPERASIAN PANEL DISTRIBUSI

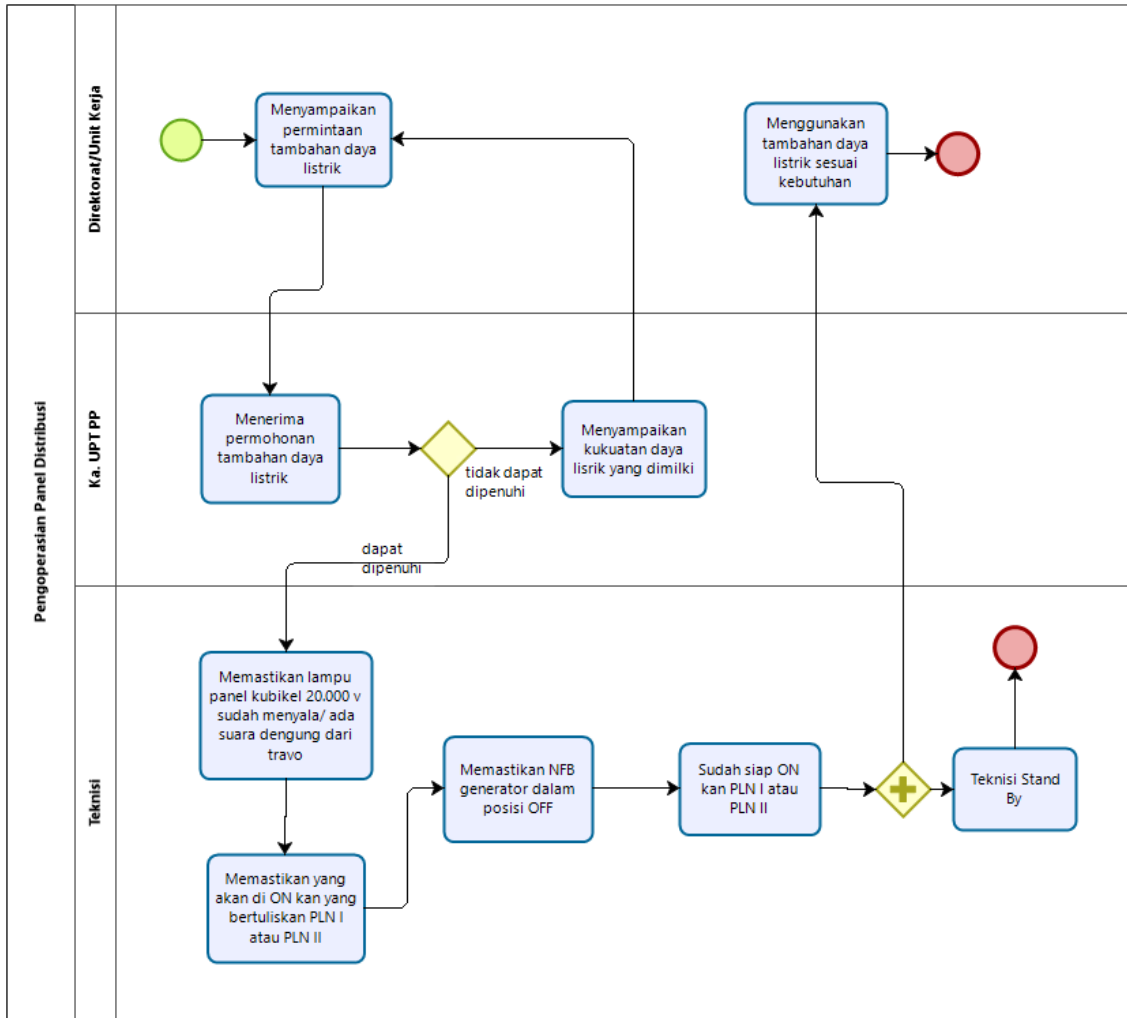

297. PENGOPERASIAN GENERATOR

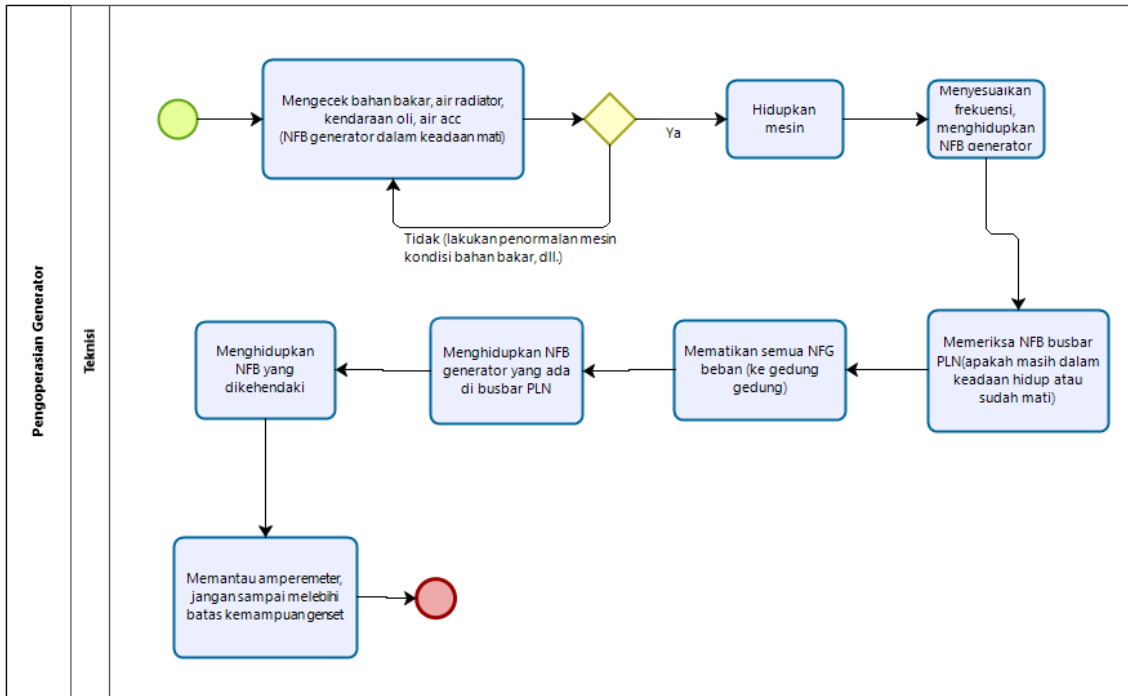

Powered by
bizagi
Modeler

298. PENGADAAN BARANG DAN JASA – P2K

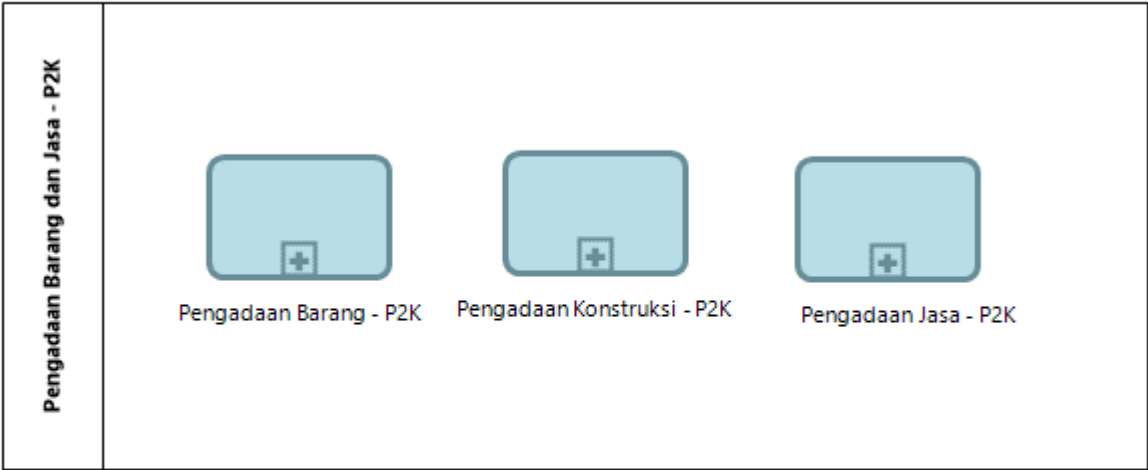

299. PENGADAAN BARANG – P2K



300. LELANG TENDER – P2K

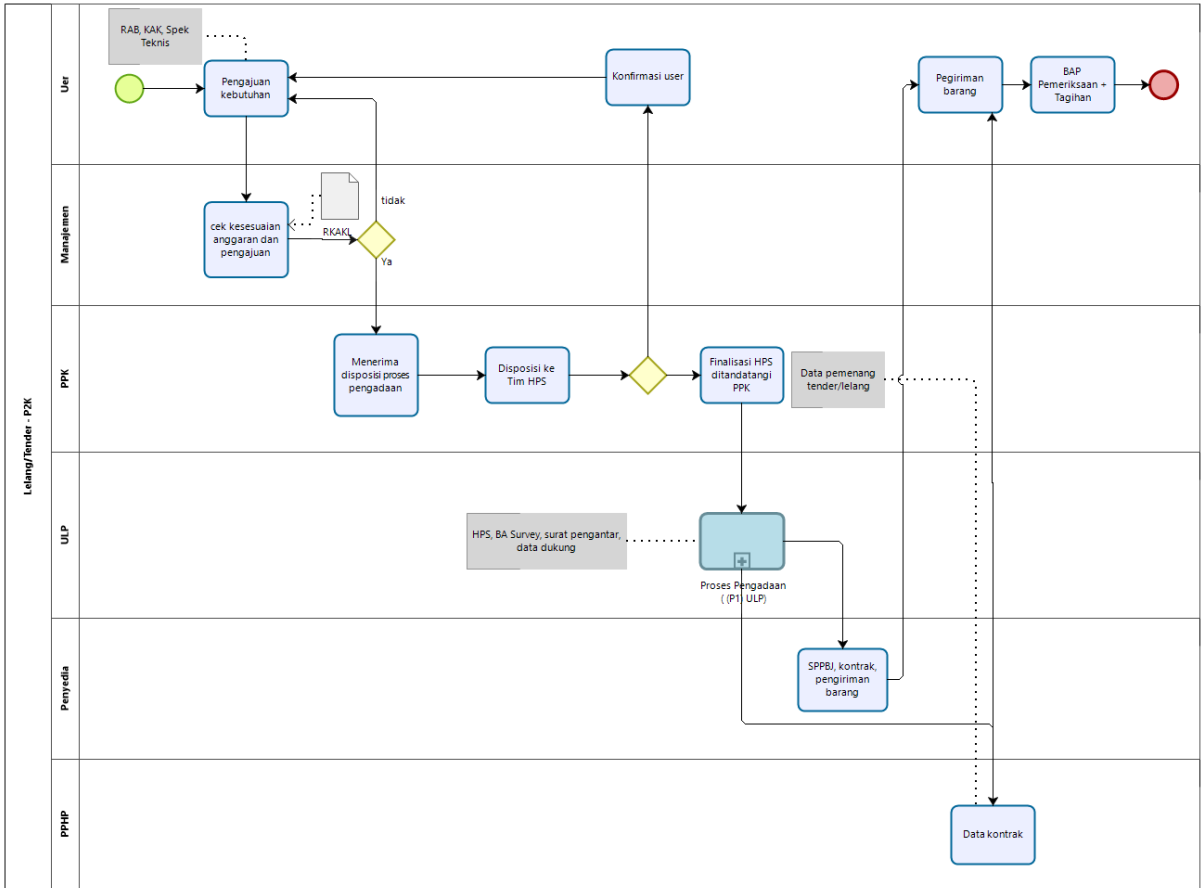

Powered by bizagi Modeler

301. PENGADAAN LANGSUNG – P2K

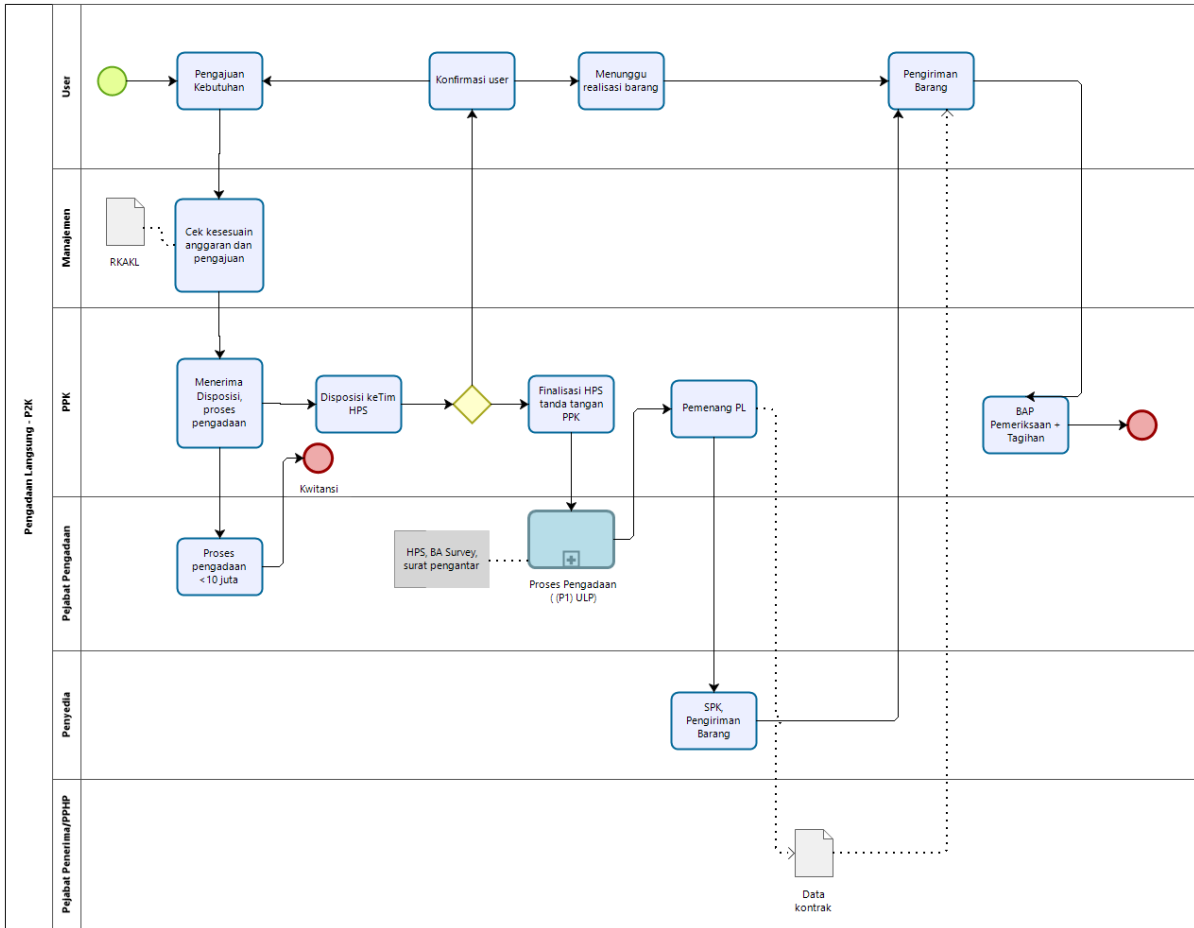

Powered by bizagi Modeler

302. E -PURCHASING – P2K

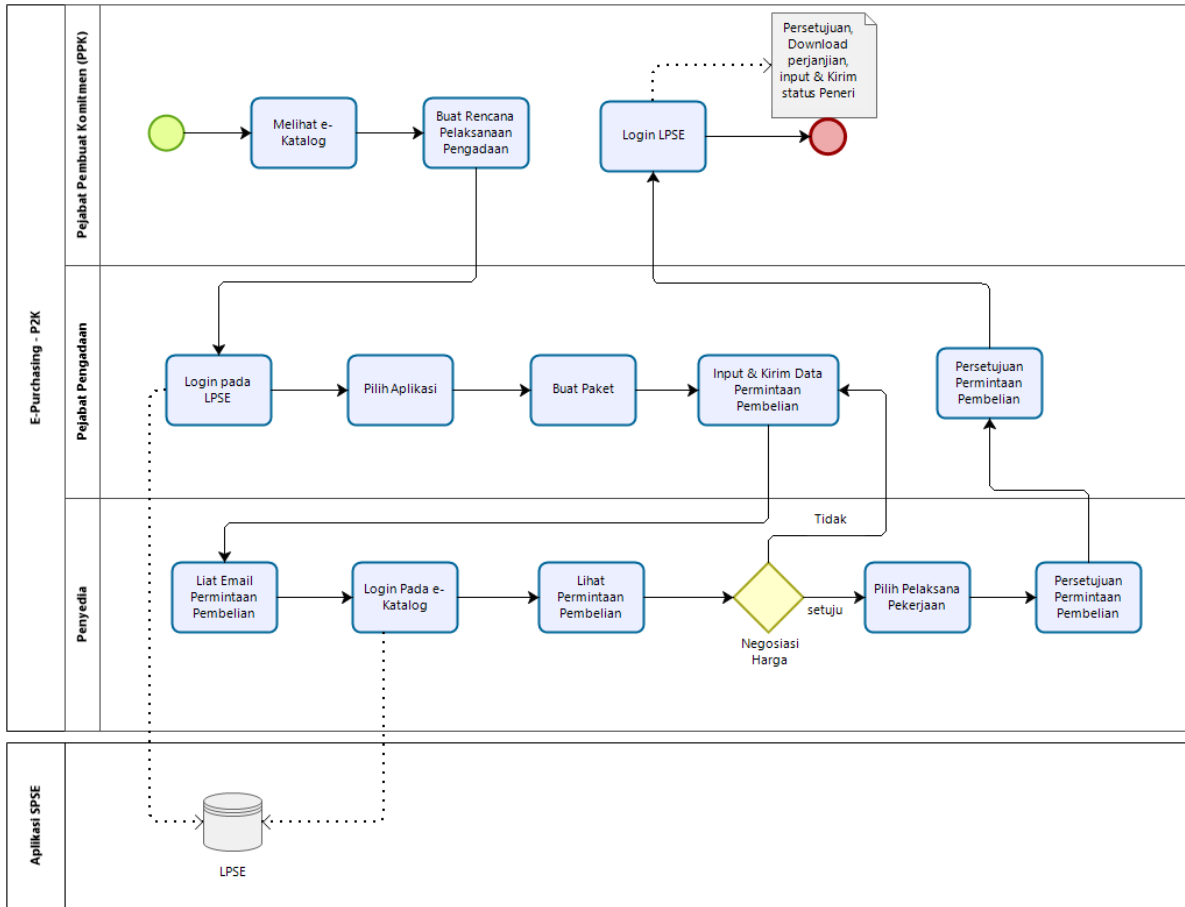

303. PENGADAAN KONSTRUKSI – P2K



Powered by
bizagi
Modeler

304. TENDER KONSTRUKSI – P2K

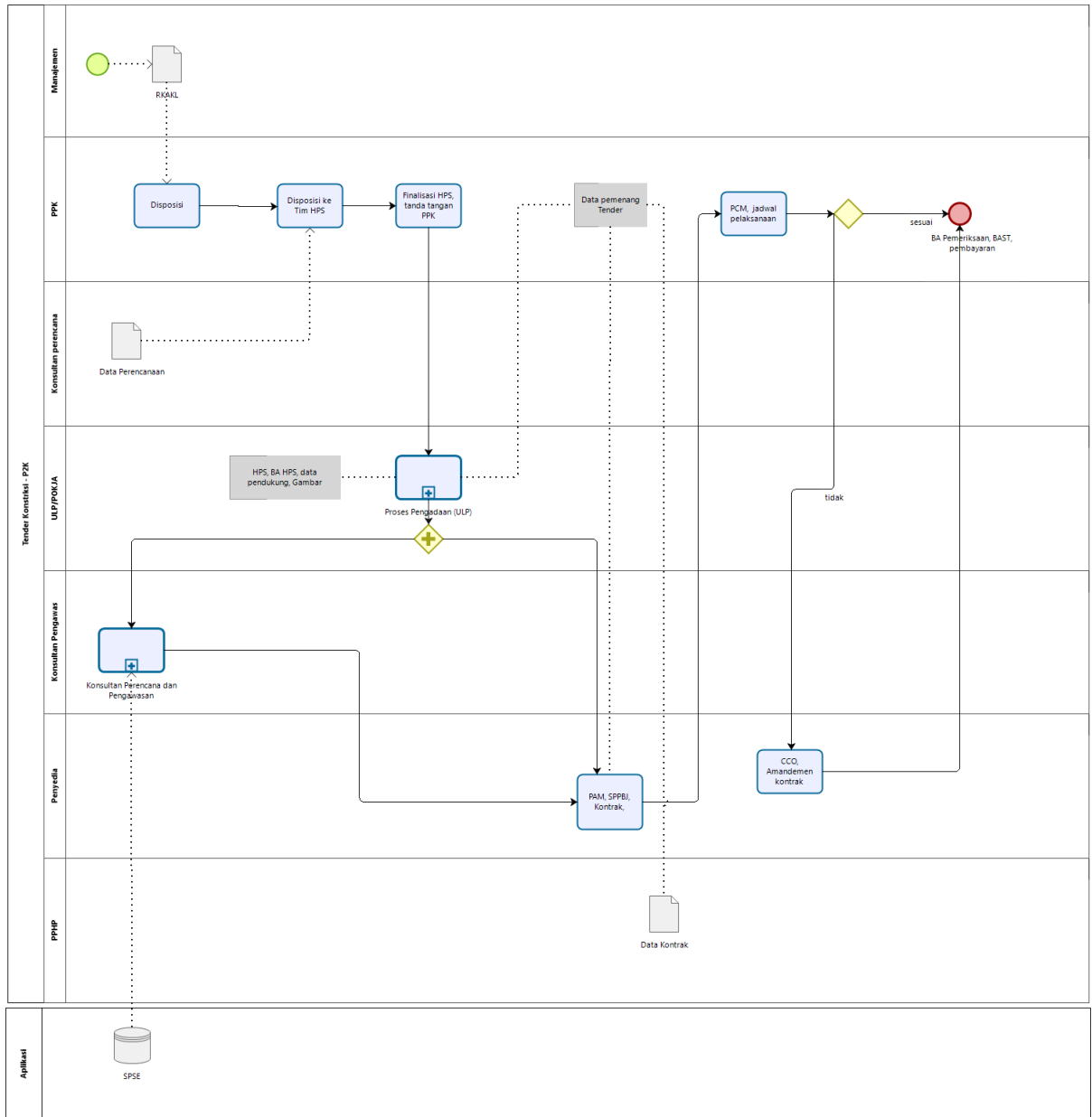

305. PENGADAAN LANGSUNG KONSTRUKSI – P2K

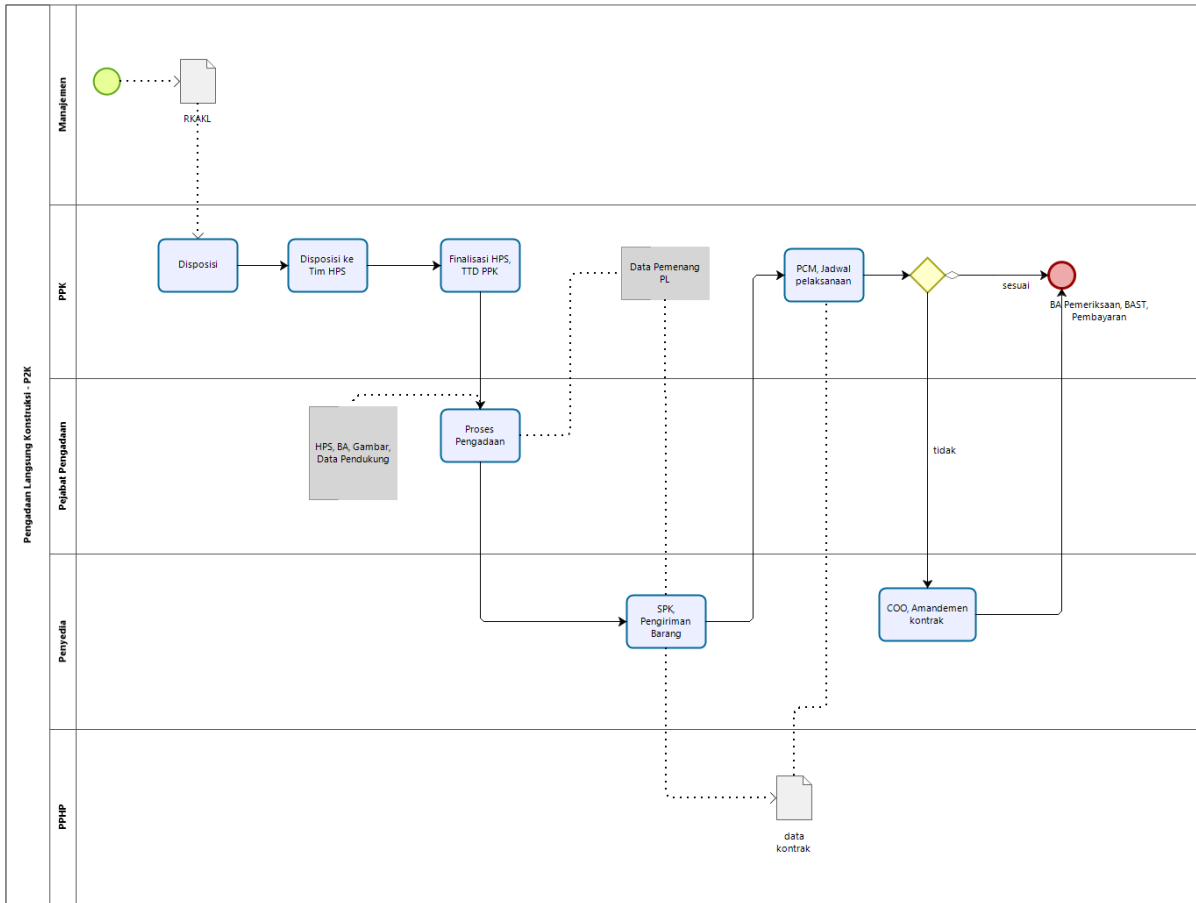

306. PENGADAAN JASA – P2K



307. KONSULTAN PERENCANA DAN PENGAWAS – P2K

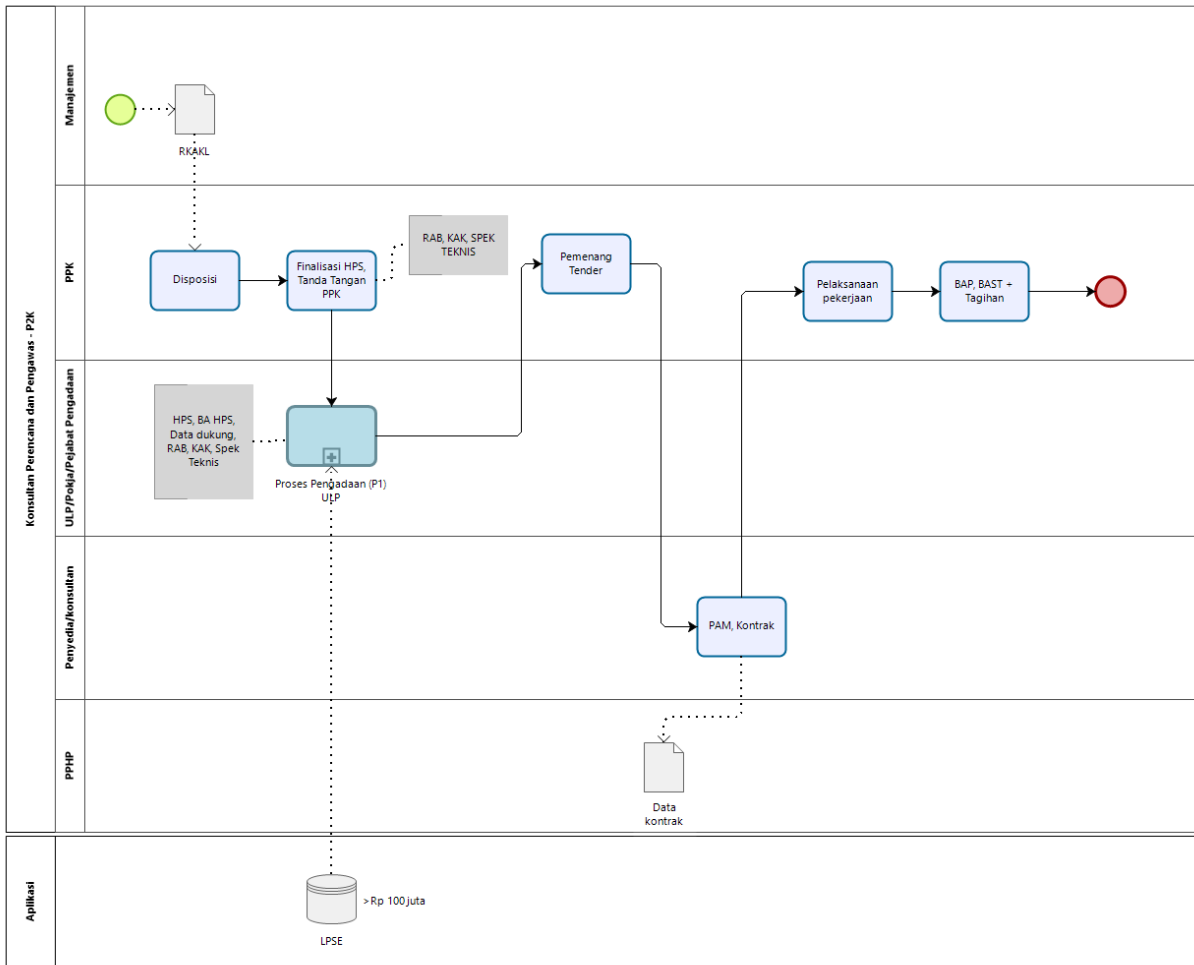

308. JASA LAINNYA – P2K

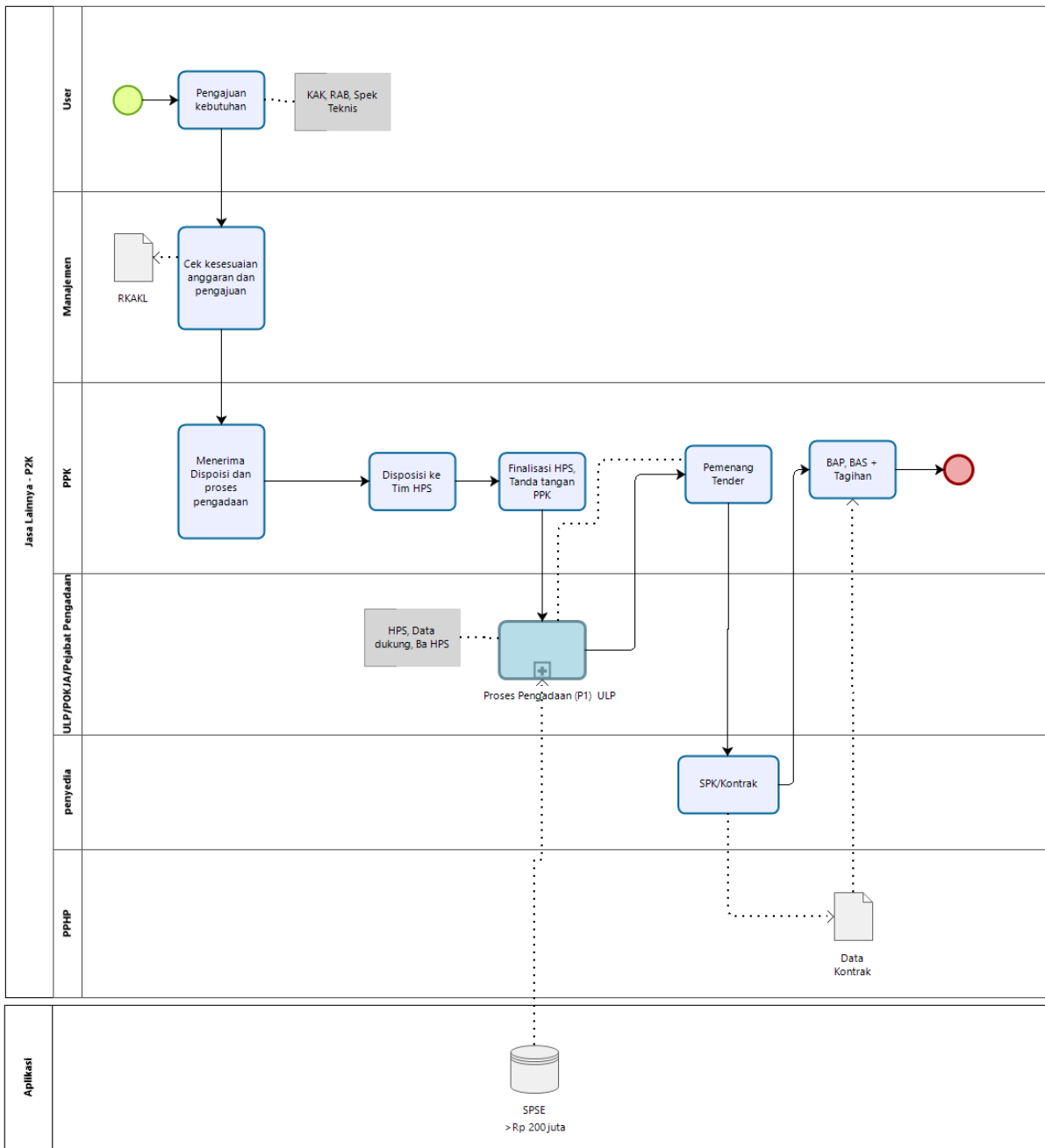

309. UNIT PENGADAAN BARANG & JASA - ULP



310. PEMILIHAN PENYEDIAAN BARANG DAN JASA



Powered by
bizagi
Modeler

311. E – PURCHASING PENGADAAN BARANG - ULP

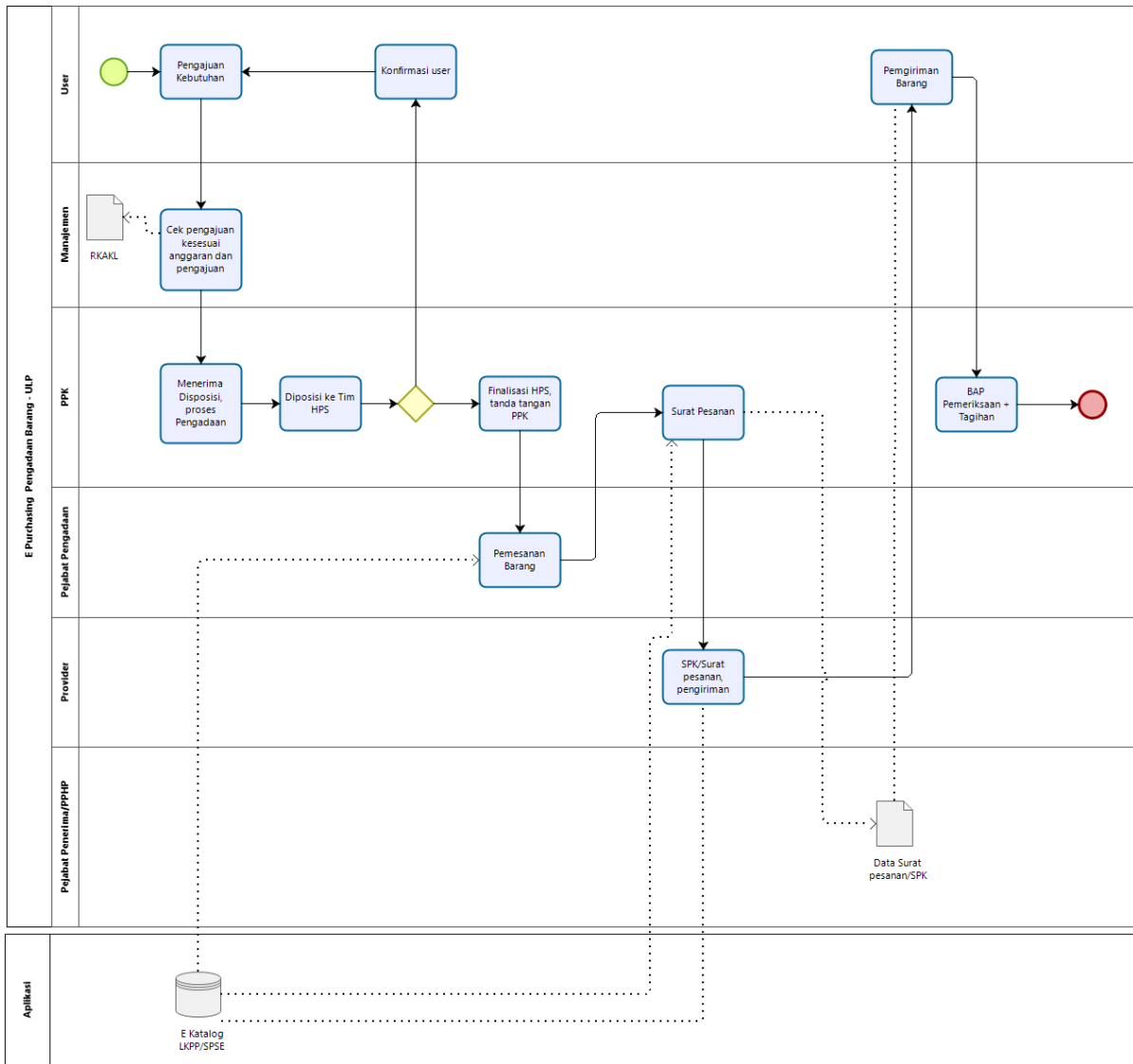

312. PENGADAAN LANGSUNG - ULP

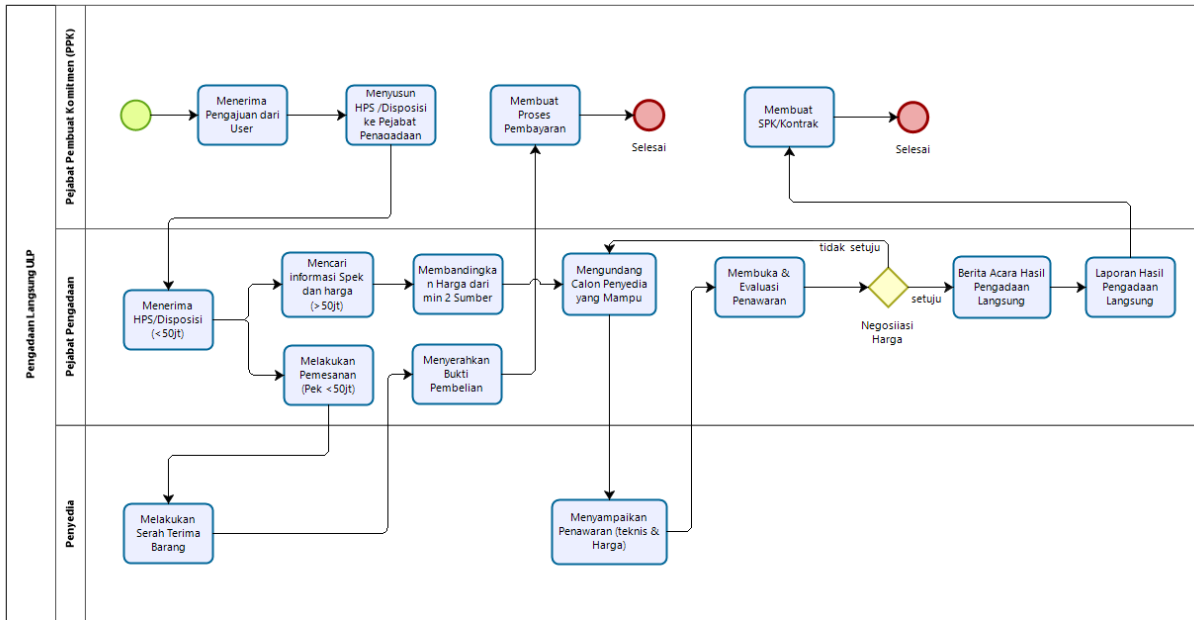

313. PENUNJUKKAN LANGSUNG – ULP

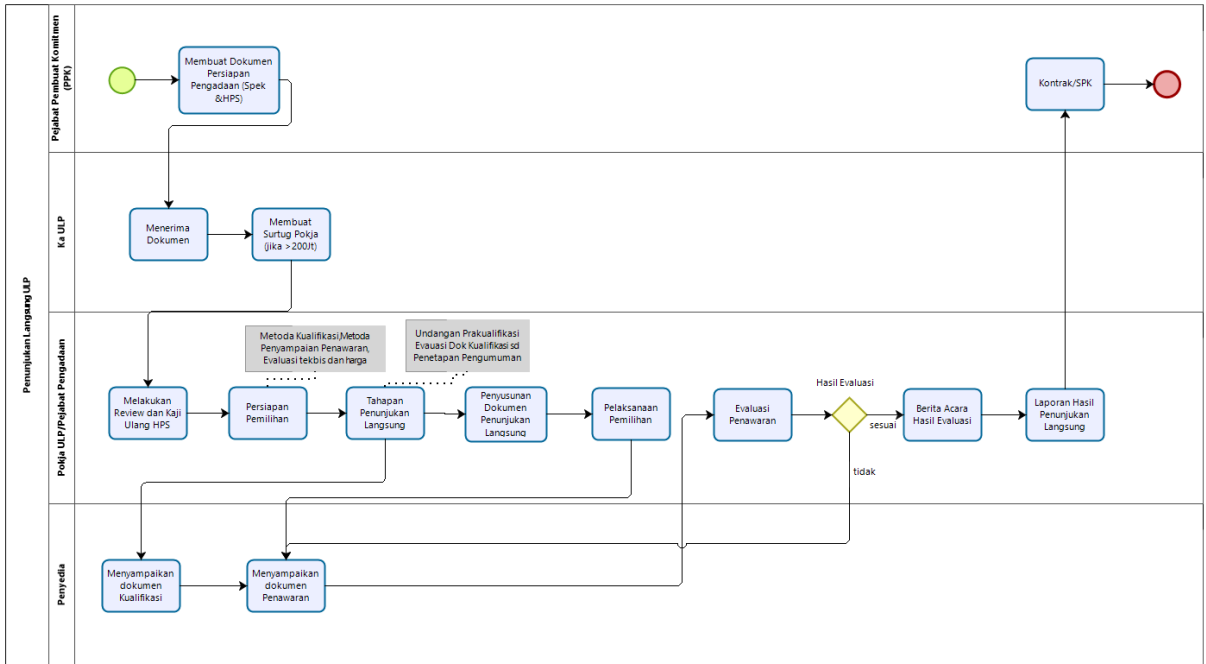

314. PROSES TENDER PENGADAAN BARANG DAN JASA - ULP

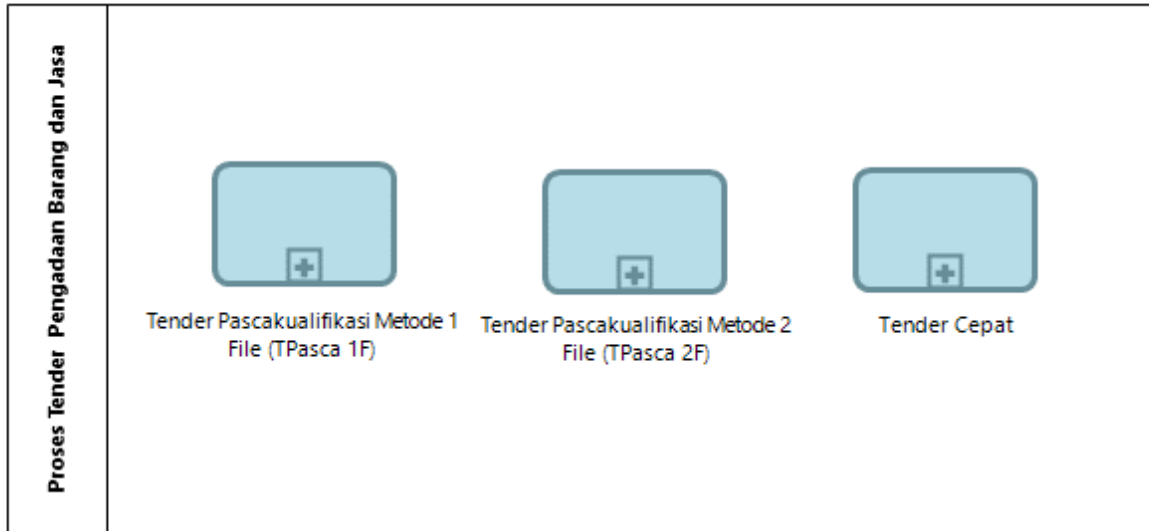

315. TENDER PASCA 1 F- ULP

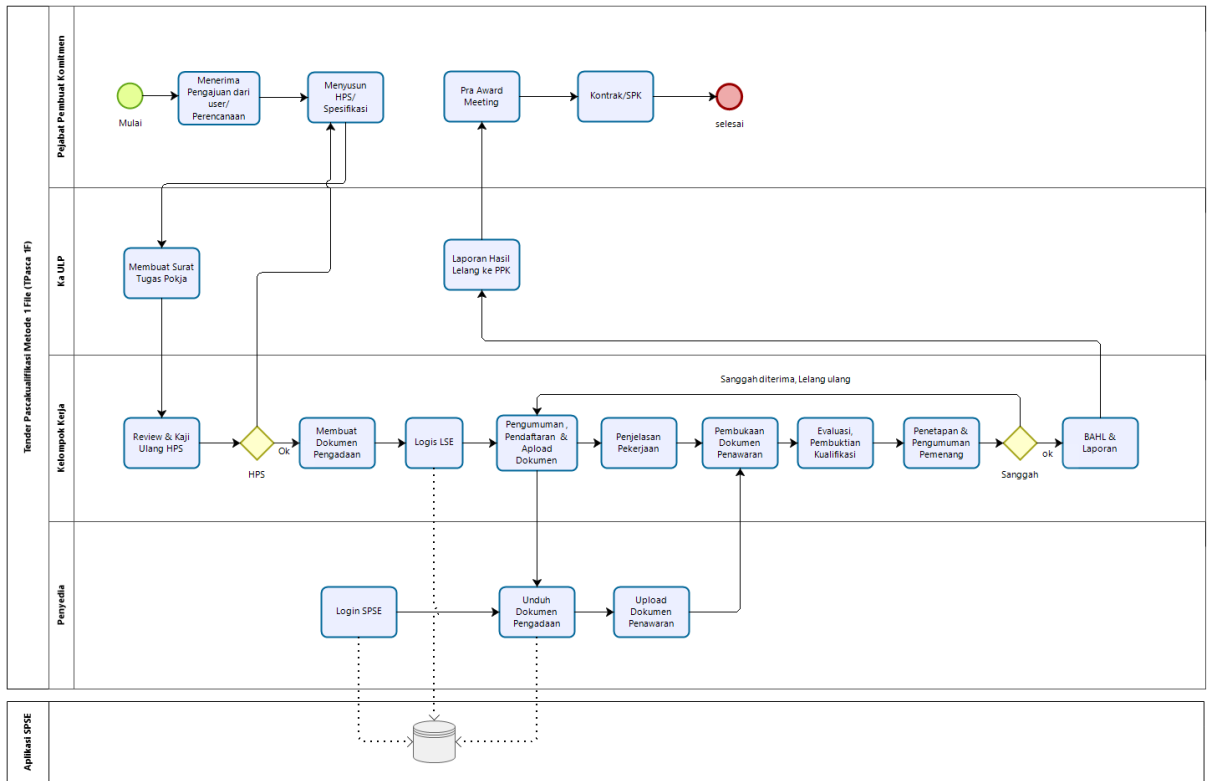

316. TENDER PASCA 2 F- ULP

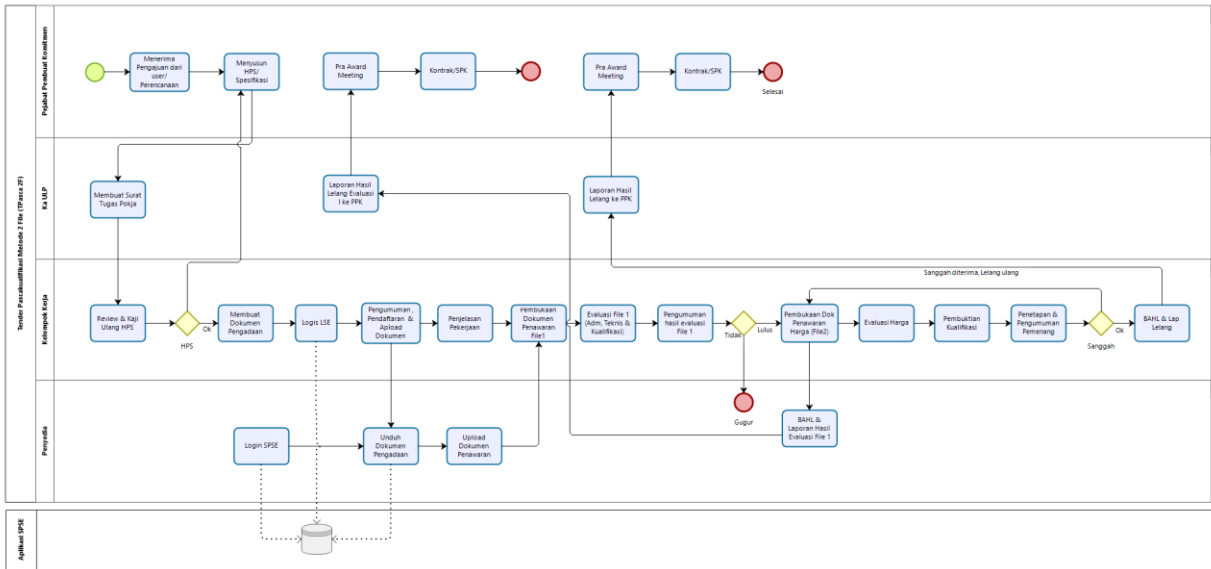

317. TENDER CEPAT- ULP

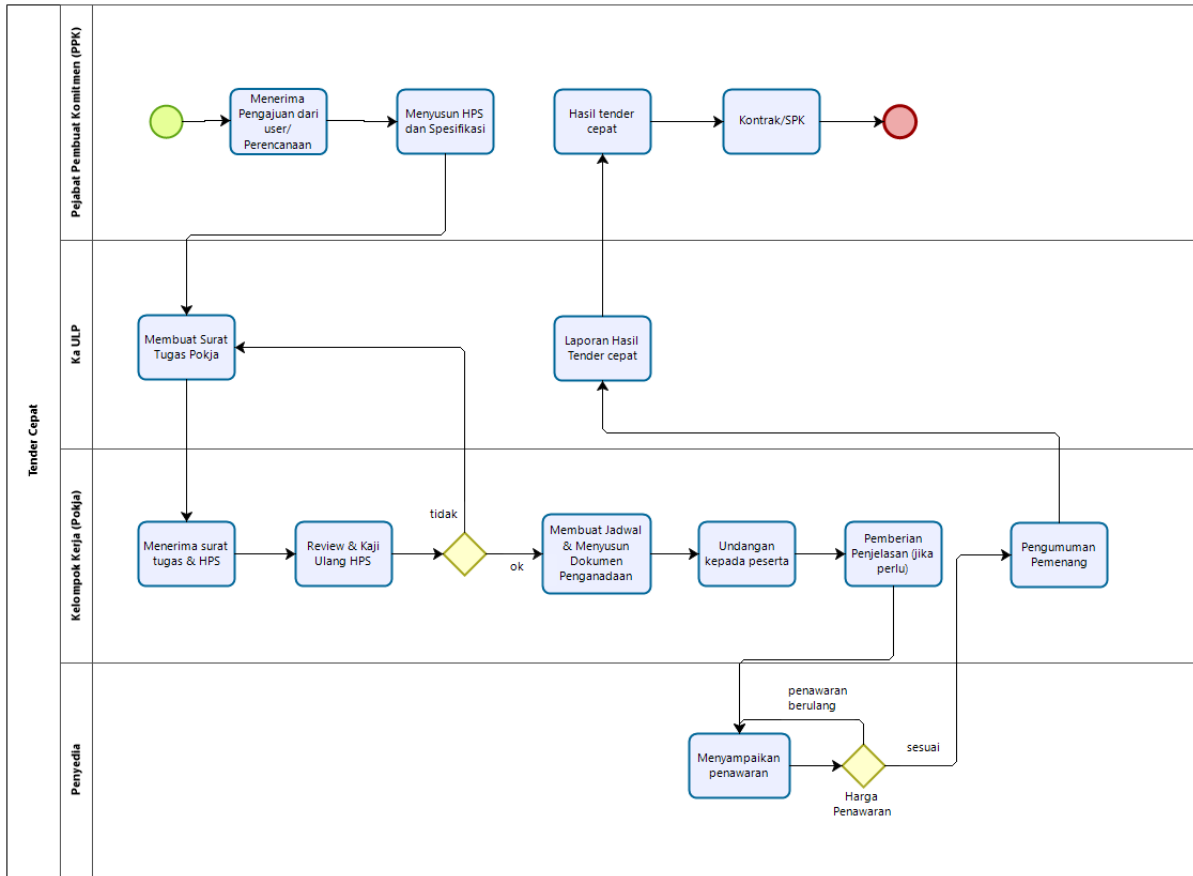

318. PENGADAAN JASA KONSULTANSI - ULP



Powered by
bizagi
Modeler

319. PENGADAAN LANGSUNG KONSULTANSI

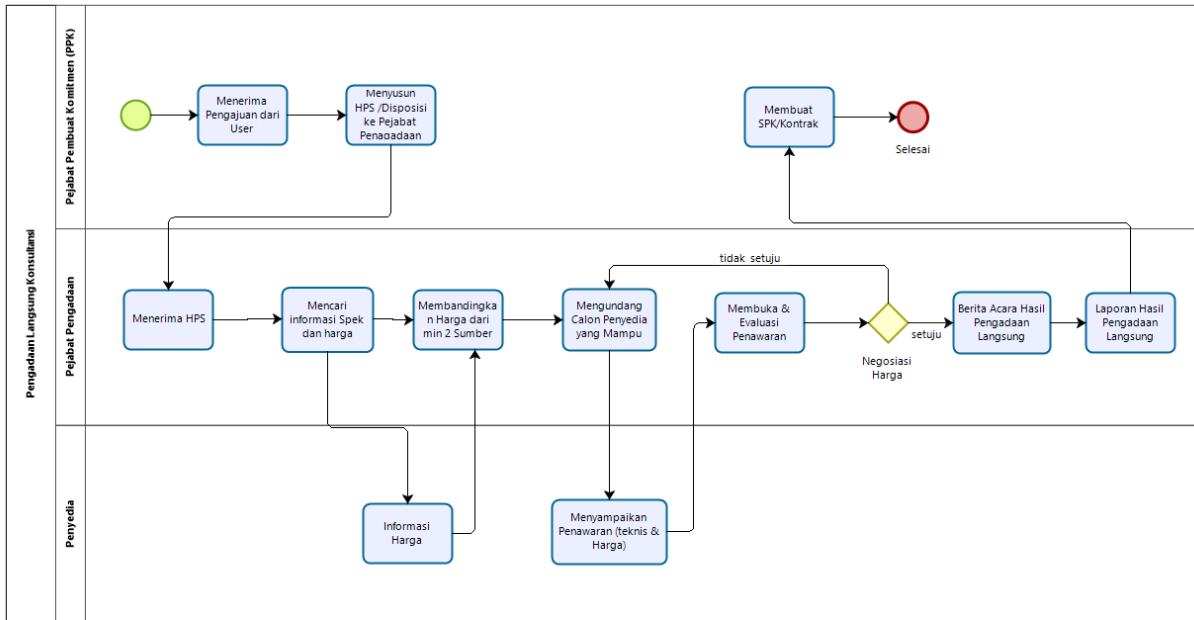

320. PENUNJUKKAN LANGSUNG KONSULTANSI

